

K 1

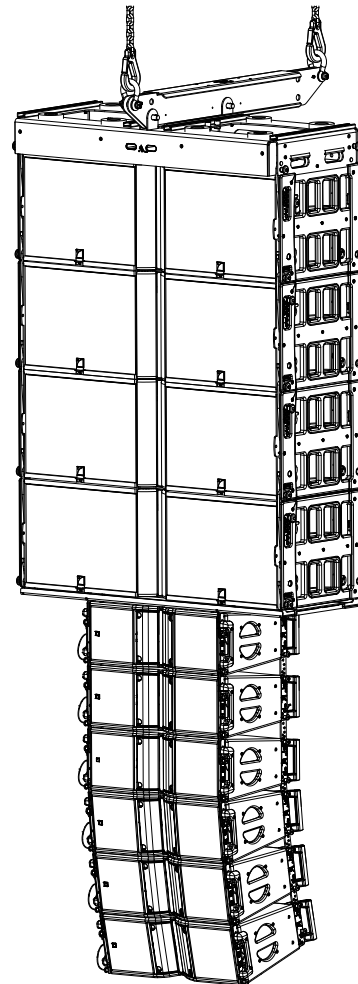

owner's manual (EN)

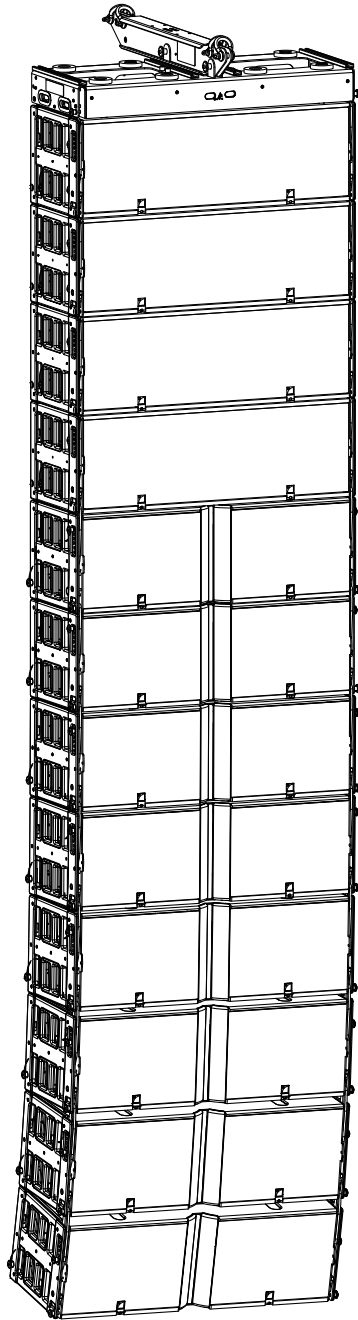

Document reference: K1 owner's manual (EN) version 2.0

Distribution date: August 21, 2024

© 2024 L-Acoustics. All rights reserved.

No part of this publication may be reproduced or transmitted in any form or by any means without the express written consent of the publisher.

Contents







Safety.....	6
Instructions.....	6
Introduction.....	8
K1 large format WST line source.....	8
How to use this manual.....	9
Revision history.....	9
System components.....	10
System component illustrations.....	11
Electro-acoustical description.....	13
Directivity.....	13
Preset description.....	14
Connectors.....	15
Rigging system description.....	17
K1/K1-SB.....	17
Rigging elements.....	19
K1-BUMP.....	19
K1-DELTA.....	22
K1-LASERMOUNT.....	22
KARA-DOWNK1.....	23
K2-LINK.....	23
Transportation.....	24
K-BUMPFLIGHT.....	24
K1-CHARIOT.....	25
K1-PLA.....	26
K1-CHARIOTCOV.....	27
K1-COV/K1-SBCOV.....	27
Mechanical safety.....	28
Loudspeaker configurations.....	30
Line source.....	30
K1-SB applications.....	32
Additional subwoofer system.....	33
K1-SB.....	34
KS28.....	36
Additional downfill element.....	38

Kara II.....	38
K2.....	40
Inspection and preventive maintenance.....	41
How to do preventive maintenance.....	41
Rigging part inspection.....	42
Mechanical system overview.....	43
K1 mixed array with K1-BUMP and K1-SB.....	44
K1 array with K1-BUMP, KARA-DOWNK1 and Kara II.....	45
K1 array with K1-CHARIOT.....	46
K1 array with K1-BUMP and LA-RAK II AVB.....	47
K2 mixed array with K1-BUMP, K1-SB, and K2-LINK.....	48
Inspection references.....	49
Grill safety.....	50
Rigging check.....	52
Acoustical check.....	58
Rigging procedures.....	62
Preparing K1-BUMP.....	62
Securing LA-RAK II AVB on K1-BUMP.....	67
Preparing a block of four K1/K1-SB.....	71
Presetting the inter-enclosure angles of K1/K1-SB.....	74
Flying K1.....	76
Flying a K1/K1-SB array with K1-BUMP.....	76
Attaching a block of four K1 under a K1 array.....	81
Attaching a block of four K2 under a K1/K1-SB array.....	85
Rigging a Kara II downfill array under a K1 array with KARA-DOWNK1.....	92
Flying a K1 array with K1-BUMP using the CATERPILLAR method.....	96
Connection to LA amplified controllers.....	104
Corrective maintenance.....	106
K1.....	107
Introduction.....	107
K1 Exploded views.....	107
Disassembly and Reassembly procedures.....	109
K1-SB.....	116
Introduction.....	116
Exploded views.....	116
Disassembly and Reassembly procedures.....	117
Specifications.....	119
K1.....	119

K2 specifications.....	120
K1-SB specifications.....	122
Kara II.....	124
KS28.....	126
K1-BPCHAIN.....	128
K1-BUMP.....	129
K1-CHARIOT2.....	130
K1-DELTA specifications.....	131
K1-LASERMOUNT specifications.....	132
K1-PLA specifications.....	133
KARA-DOWNK1 specifications.....	134
K2-LINK specifications.....	135
K-BUMPFLIGHT specifications.....	136
KS28-OUTRIG.....	137
APPENDIX A: Recommendation for speaker cables.....	138
APPENDIX B: Installing a laser inclinometer.....	139
K1-LASERMOUNT.....	139
K1-BUMP.....	140
With TEQSAS® LAP-TEQ PLUS / LAP-TEQ / KSG® RECLINE Compact.....	140
With SSE® Prosight.....	141

Safety

Instructions

-  **Inspect the system before any deployment.**
Perform safety related checks and inspections before any deployment.
- Perform preventive maintenance at least once a year.**
Refer to the preventive maintenance section for a list of actions and their periodicity.
Insufficient upkeep of the product can void the warranty.
- If any safety issue is detected during inspection, do not use the product before performing corrective maintenance.**
Check for issues. A rigging system part or fastener is missing or loose. A rigging system part exhibits: bends, breaks, broken parts, corrosion, cracks, cracks in welded joints, deformation, denting, wear, holes. A safety cue or label is missing.
-  **Never incorporate equipment or accessories not approved by L-Acoustics.**
-  **Read all the related PRODUCT INFORMATION documents shipped with the products before exploiting the system.**
-  **Do not store the product on an unstable cart, stand, tripod, bracket, or table.**
-  **Beware of sound levels.**
Do not stay within close proximity of loudspeakers in operation.
Loudspeaker systems are capable of producing very high sound pressure levels (SPL) which can instantaneously lead to permanent hearing damage to performers, production crew, and audience members. Hearing damage can also occur at moderate level with prolonged exposure to sound.
Check the applicable laws and regulations relating to maximum sound levels and exposure times.
-  **Work with qualified personnel for rigging the system.**
Installation should only be carried out by qualified personnel that are familiar with the rigging techniques and safety recommendations outlined in this manual.
- Ensure personnel health and safety.**
During installation and set-up personnel must wear protective headgear and footwear at all times. Under no circumstances is personnel allowed to climb on a loudspeaker assembly.
- Respect the Working Load Limit (WLL) of third party equipment.**
L-Acoustics is not responsible for any rigging equipment and accessories provided by third party manufacturers. Verify that the Working Load Limit (WLL) of the suspension points, chain hoists and all additional hardware rigging accessories is respected.
- Respect the maximum configurations and the recommended safety precautions.**
For safety issue, respect the maximum configurations outlined in this manual. To check the conformity of any configuration in regards with the safety precautions recommended by L-Acoustics, model the system in Soundvision and refer to the warnings in Mechanical Data section.
- Be cautious when flying a loudspeaker configuration.**
Before installing/raising the product, check each individual element to make sure that it is securely fastened to the adjacent element. Always verify that no one is standing underneath the product when it is being installed/raised. Never leave the product unattended during the installation process.
As a general rule, L-Acoustics recommends the use of secondary safety at all times.
- Be cautious when ground-stacking a loudspeaker array.**
Do not stack the loudspeaker array on unstable ground or surface. If the array is stacked on a structure, platform, or stage, always check that the latter can support the total weight of the array.
As a general rule, L-Acoustics recommends the use of safety straps at all times.

Risk of falling objects

Verify that no unattached items remain on the product or assembly.

Risk of tipping

Remove all rigging accessories before transporting a product or an assembly.

Take into account the wind effects on dynamic load.

When a loudspeaker assembly is deployed in an open air environment, wind can produce dynamic stress to the rigging components and suspension points.

If the wind force exceeds 6 bft (Beaufort scale), lower down and/or secure the product or the assembly.

**Intended use**

This system is intended for use by trained personnel for professional applications.



As part of a continuous evolution of techniques and standards, L-Acoustics reserves the right to change the specifications of its products and the content of its documents without prior notice.

Check www.l-acoustics.com on a regular basis to download the latest document and software updates.

**Long term exposure to extreme conditions may damage the product.**

For more information, refer to the **Products weather protection** document, available on the website.

**Read the maintenance section of this document before servicing the product.****Contact L-Acoustics for advanced maintenance.**

Any unauthorized maintenance operation will void the product warranty.



This marking indicates that this product should not be disposed of with other household waste throughout the EU. To prevent possible harm to the environment or human health from uncontrolled waste disposal, recycle it responsibly to promote the sustainable reuse of material resources. To return your used device, please use the return and collection systems or contact the retailer where the product was purchased. They can take this product for environmentally safe recycling.



Introduction

K1 large format WST line source



The K1 enclosure is the full-range element of a large format WST[®] line source with variable curvature. The K1 features two 15" speakers mounted in a bass-reflex enclosure, four 6.5" high-efficiency direct radiating speakers, and three 3" diaphragm compression drivers coupled to individual DOSC[®] waveguides. The transducers are implemented in a K-shape configuration. The K1 enclosure is based on a 3-way active design with 2 LF sections, 1 MF section and 1 HF section, each one at the nominal impedance of 8 ohms. The K1 enclosure is made of first grade Baltic birch plywood to ensure maximum acoustical and mechanical integrity. A four-point rigging system is integrated into the cabinet.

The K1 enclosure operates over the nominal frequency range of 35 Hz to 20 kHz. The frequency response of the system can be extended down to either 30 Hz or 25 Hz with the addition of the dedicated K1-SB extension, or the KS28 subwoofer, respectively. The K1 generates a symmetric horizontal coverage of 90°.

The rigging system allows vertically assembling K1 enclosures with various inter-element angles up to 5°, constituting a line array with variable curvature. The combination of the coplanar symmetry and the DOSC[®] waveguide in the HF region ensure a perfect acoustic coupling between the elements of an array. The WST[®] (Wavefront Sculpture Technology) criteria are fulfilled, so that such an array can be qualified as a true line source. Any WST[®] line source provides a smooth tonal response and a coverage that is free of secondary lobes over the entire frequency range.

The K1 system is driven by the LA12X amplified controllers which ensure active system linearization, intelligent transducer protection, and optimization of the loudspeaker system in its different operating modes. The acoustic performances of the system will depend upon the used preset and the chosen physical configuration

How to use this manual

The K1 owner's manual is intended for all actors involved in the system design, implementation, preventive and corrective maintenance of the K1 system. It must be used as follows:

1. Read the technical description for an overview of all system elements, their features, and their compatibilities.
 - [Electro-acoustical description](#) (p.13)
 - [Rigging system description](#) (p.17)
2. Prepare the system configuration. Consider the mechanical limits and the available acoustical configurations.
 - [Mechanical safety](#) (p.28)
 - [Loudspeaker configurations](#) (p.30)
3. Before rigging the system, perform mandatory inspections and functional checks.
 - [Inspection and preventive maintenance](#) (p.41)
4. To deploy the system, follow the step-by-step rigging instructions and refer to the cabling schemes.
 - [Rigging procedures](#) (p.62)
 - [Connection to LA amplified controllers](#) (p.104)



The [Corrective maintenance](#) (p.106) section contains the operations authorized for the end user. Performing another operation exposes to hazardous situations. For advanced maintenance, contact your L-Acoustics representative.

As part of a continuous evolution of techniques and standards, L-Acoustics reserves the right to change the specifications of its products and the content of its document without prior notice. Please check www.l-acoustics.com on a regular basis to download the latest document and software updates.

Contact information

For information on advanced corrective maintenance:

- contact your Certified Provider or your L-Acoustics representative
- for Certified Providers, contact the L-Acoustics customer service: customer.service@l-acoustics.com (EMEA/APAC), laus.service@l-acoustics.com (Americas).

Symbols

The following symbols are used in this document:



This symbol indicates a potential risk of harm to an individual or damage to the product.

It can also notify the user about instructions that must be strictly followed to ensure safe installation or operation of the product.



This symbol notifies the user about instructions that must be strictly followed to ensure proper installation or operation of the product.



This symbol notifies the user about complementary information or optional instructions.

Revision history

version number	publication date	modification
1.0	Jun. 2024	Initial version.
2.0	Aug. 2024	<ul style="list-style-type: none"> • Updated K1-DELTA (p.22) • Updated Corrective maintenance (p.106). • Updated Specifications (p.119)

System components

Loudspeaker enclosures

K1	3-way full-range active WST® enclosure
K1-SB	K1 system subwoofer 2×15"
K2	3-way full-range active WST enclosure
Kara II	2-way active WST® enclosure: 2 × 8" LF + 3" HF diaphragm
KS28	Flyable subwoofer 2 × 18"

Powering and driving system

LA12X	Amplified controller 4 × 2600 W / 4 ohms
-------	--



Refer to the LA12X owner's manual for operating instructions.

Racks

LA-RAK II AVB	Touring rack containing three LA12X, LA-POWER II for power distribution, LA-PANEL II for audio and network distribution, and two LS10 for AVB distribution
---------------	--

Cables

SP cables	SpeakON loudspeaker cables (4-point, 4 mm ² gauge) Come in different sizes: SP.7 (0.7 m / 2.3 ft), SP5 (5 m / 16.4 ft), SP10 (10 m / 32.8 ft), and SP25 (25 m / 82 ft)
SP-Y1	Breakout cable for two passive enclosures (2.5 mm ² gauge) 4-point speakON to 2 × 2-point speakON, provided with a CC4FP adapter
DO cables	PA-COM loudspeaker cables (8-point, 4 mm ² gauge) Come in different sizes: DO.7 (0.7 m / 2.3 ft), DO.10 (10 m / 32.8 ft), and DO.25 (25 m / 82 ft)
DOSUB-LA8	Breakout cable for four passive enclosures (4 mm ² gauge) 8-point PA-COM to 4 × 2-point speakON
DOFILL-LA8	Breakout cable for two 2-way active enclosures (4 mm ² gauge) 8-point PA-COM to 2 × 4-point speakON
DO3WFILL	Breakout cable for one 2-way active enclosure and two passive enclosures (4 mm ² gauge) 8-point PA-COM to 1 × 4-point speakON and 2 × 2-point speakON



Information about the connection of the enclosures to the LA amplified controllers is given in this document.

Refer to the LA12X owner's manual for detailed instructions about the whole cabling scheme, including modulation cables and network.

Rigging elements

K1-BUMP	Structure for flying and stacking K1 and K1-SB arrays
K1-DELTA	Rigging accessory for rear attachment of 2 motors to K1-BUMP
KARA-DOWNK1	Flying bumper for rigging KARA (II) under K1 or K1-SB
K1-LASERMOUNT	K1 laser support plate (compatible TEQSAS / SSE ProSight / Align Array / KSG)
K2-LINK	Rigging accessory for rear attachment of K2 below K1

Transportation accessories

K-BUMPLIGHT	Modular flight case for 2 K1-BUMP or 2 K2-BUMP
K1-CHARIOT	Chariot for 4 × K1 or 4 × K1-SB
K1-CHARIOTCOV	Protective cover for 4 × K1/K1-SB on CHARIOT
K1-PLA	Removable front dolly for K1 or K1-SB enclosure
K1-COV	Protective cover for K1 enclosure
K1-SBCOV	Protective cover for K1-SB enclosure

Software applications

Soundvision	3D acoustical and mechanical modeling software
LA Network Manager	Software for remote control and monitoring of amplified controllers



Refer to the Soundvision help.

Refer to the LA Network Manager help.

System component illustrations

Cables

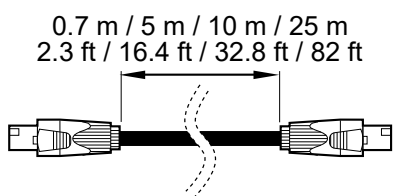

SP cables

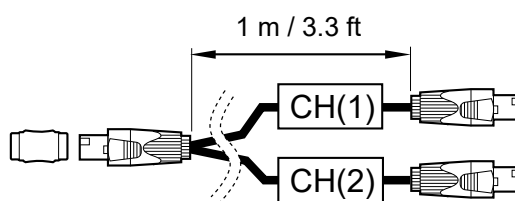

SP-Y1

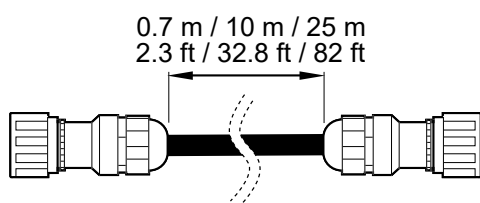

DO cables

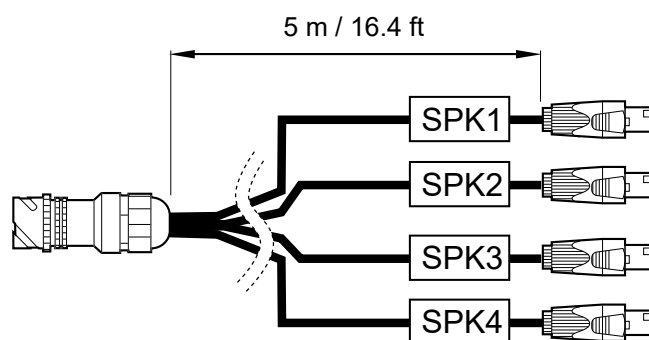

DOSUB-LA8

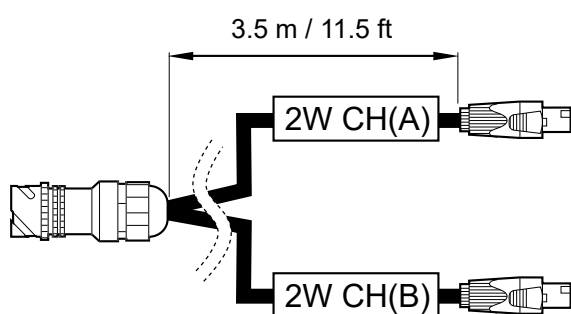

DOFILL-LA8

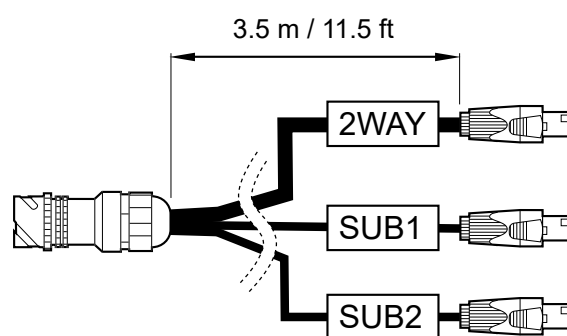

DO3WFILL

Rigging accessories

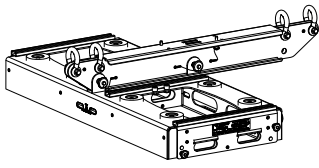

K1-BUMP

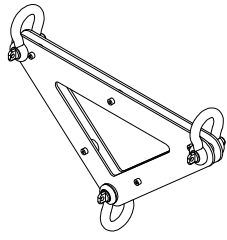

K1-DELTA

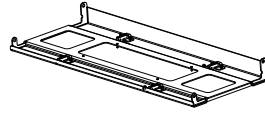

KARA-DOWNK1

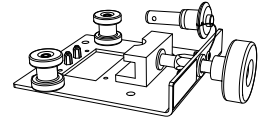

K1-LASERMOUNT

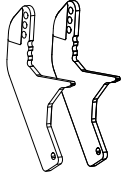

K2-LINK

Software applications

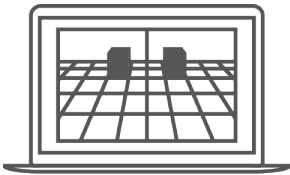

Soundvision



LA Network Manager

Transportation

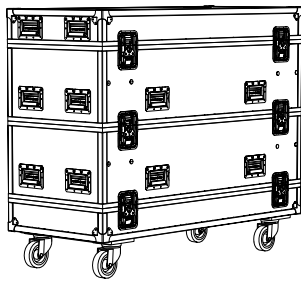

K-BUMPFLIGHT

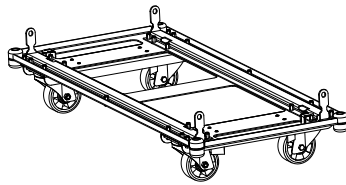

K1-CHARIOT

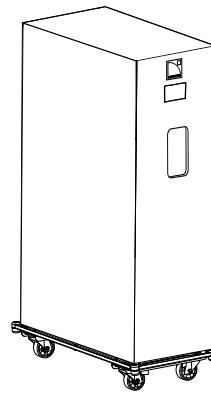

K1-CHARIOTCOV

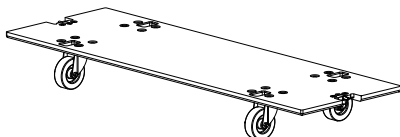

K1-PLA

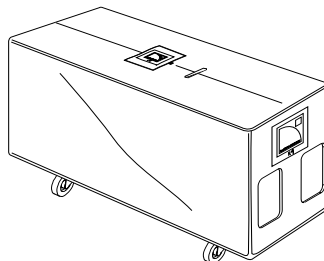

K1-COV

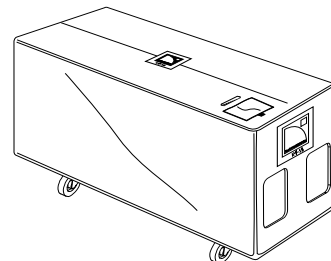

K1-SBCOV

Electro-acoustical description

Directivity

Horizontal

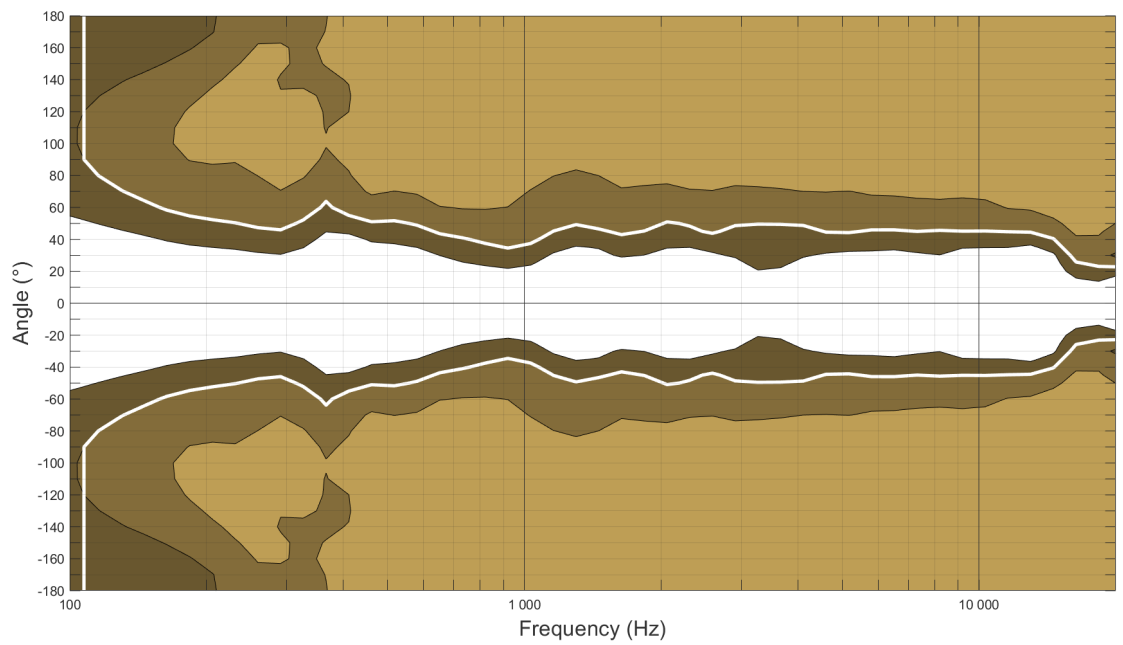
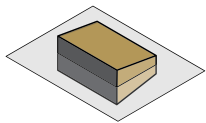

Dispersion angle diagram of a K1 array, using lines of equal sound pressure at -3 dB, -6 dB, -12 dB.

Preset description

[K1] [K2 70] [K2 90] [K2 110]

loudspeaker elements	outputs	channels	routing	gain	delay	polarity	mute
left LF	OUT 1	LF	IN A	0 dB	0 ms	+	ON
right LF	OUT 2	LF					ON
MF	OUT 3	MF					ON
HF	OUT 4	HF					ON

[KARAIIDOWNK1] [KARAIIDOWNK1 70] [KARAIIDOWNK1 90]

loudspeaker elements	outputs	channels	routing	gain	delay	polarity	mute
LF	OUT 1	LF	IN A	0 dB	0 ms	+	ON
HF	OUT 2	HF					ON
LF	OUT 3	LF	IN A	0 dB	0 ms	+	ON
HF	OUT 4	HF					ON

[K1SB_60] [K1SB_X] [KS28_60]

outputs	channels	routing	gain	delay	polarity	mute
OUT 1	SB	IN A	0 dB	0 ms	+	ON
OUT 2	SB	IN A	0 dB	0 ms	+	ON
OUT 3	SB	IN A	0 dB	0 ms	+	ON
OUT 4	SB	IN A	0 dB	0 ms	+	ON

[KS28_60_C] [KS28_60_Cx]

loudspeaker elements	outputs	channels	routing	gain	delay	polarity	mute
SR	OUT 1	SR	IN A	0 dB	0 ms	+	ON
SB	OUT 2	SB					ON
SB	OUT 3	SB					ON
SB	OUT 4	SB					ON

Connectors

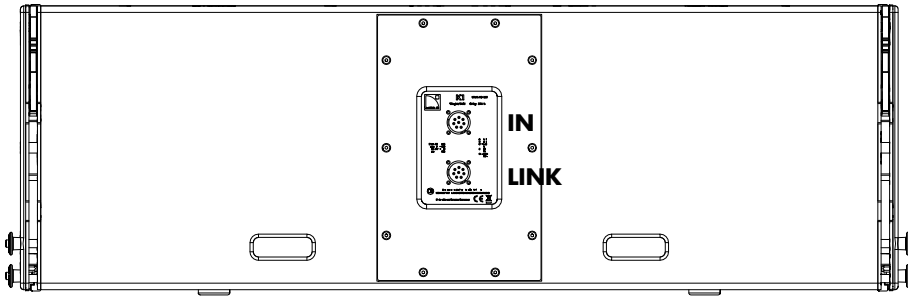

K1

2 x 8-point PA-COM

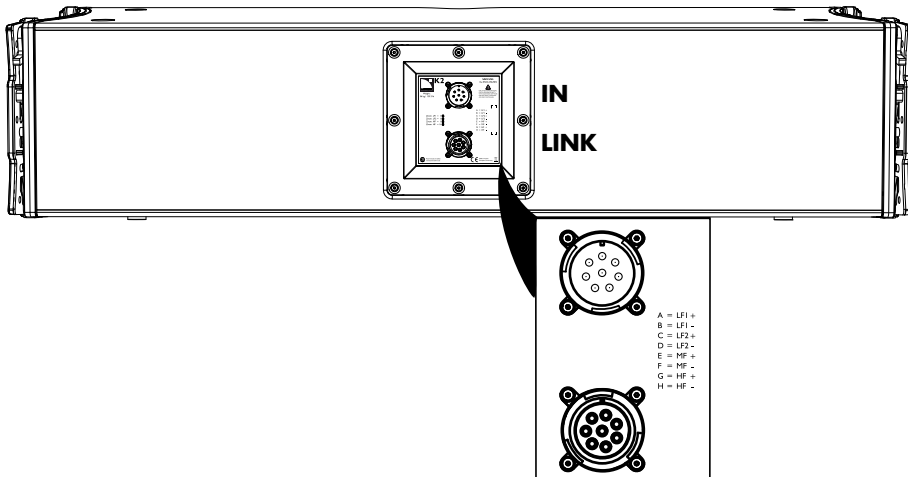

K2

2 x 8-point PA-COM

Internal pinout for L-Acoustics 3-way active enclosures

PA-COM points	A/B	C/D	E/F	G/H
Transducer connectors	left LF	right LF	MF	HF

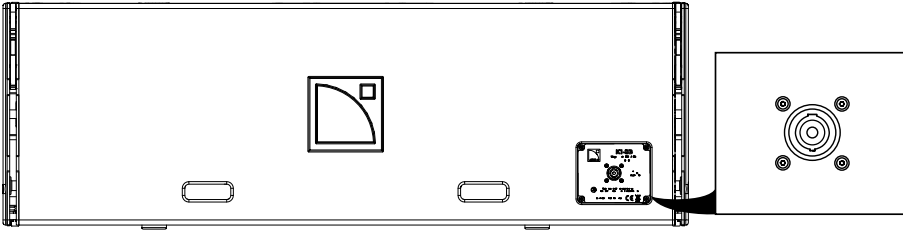

K1-SB

1 x 4-point speakON

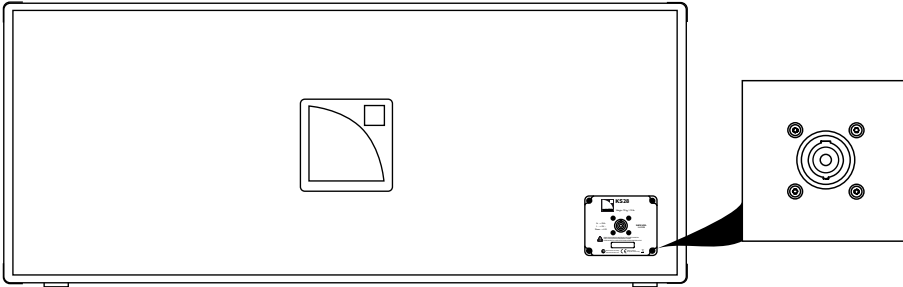

KS28

1 x 4-point speakON

Internal pinout for L-Acoustics subwoofers

SpeakON points	1 +	1 -	2 +	2 -
Transducer connectors	LF +	LF -	Not linked	Not linked

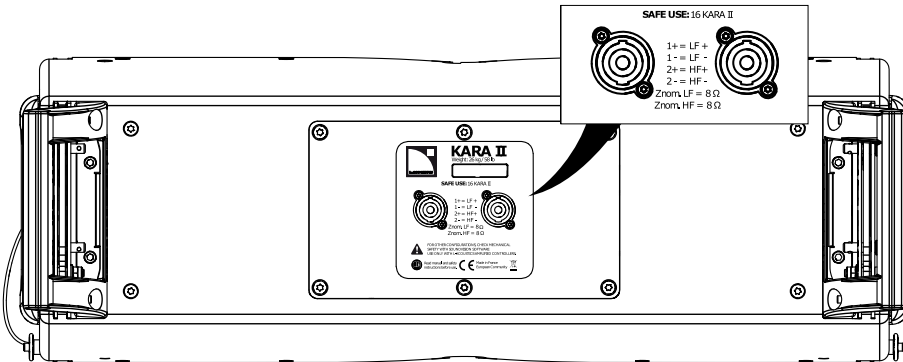

Kara II

2 x 4-point speakON

Internal pinout for L-Acoustics 2-way active enclosures

SpeakON points	1 +	1 -	2 +	2 -
Transducer connectors	LF +	LF -	HF +	HF -

Rigging system description

K1/K1-SB

On both sides, K1/K1-SB integrates two arms to connect another element of the rigging system, such as an enclosure or to a flying frame:

- At the front, a sliding arm enables the inter-element angle setting and the inter-element front connection. Nine angle positions are available: 0°, 0.5°, 1°, 1.5°, 2°, 2.5°, 3°, 4°, 5°.
- At the rear, a rotating arm enables the inter-element rear connection.

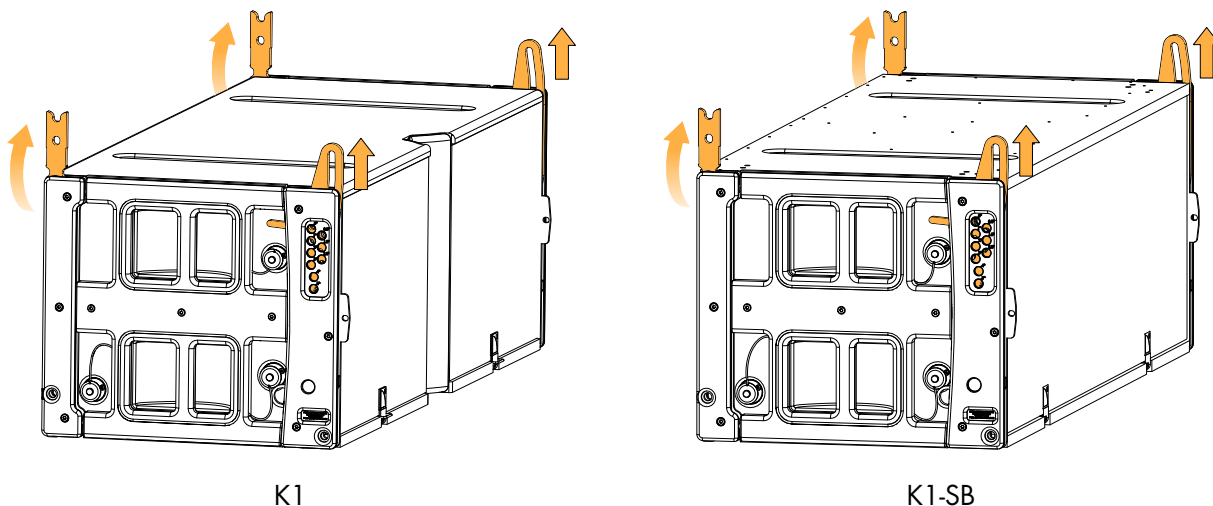

The rigging arms are secured with three ball-locking pins on each side of the enclosure:

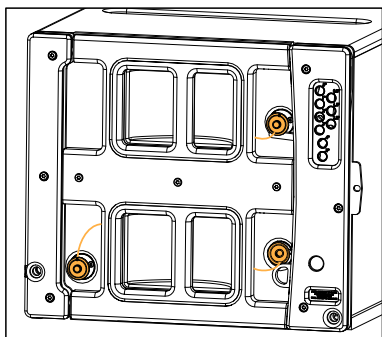

Ball-locking pins in storage position

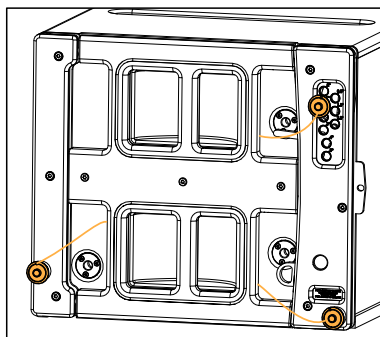

Ball-locking pins in rigging position

Adjacent enclosures or rigging accessories are secured by an automatic system with buttons and latches. The system is activated in advance and locks itself during the stacking and lifting procedures.

The rigging elements and latches are fitted with yellow safety labels that are visible when they are not safely locked.

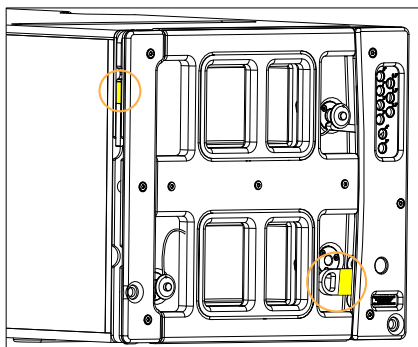

Two ergonomic handles on each side of K1 are available for handling.

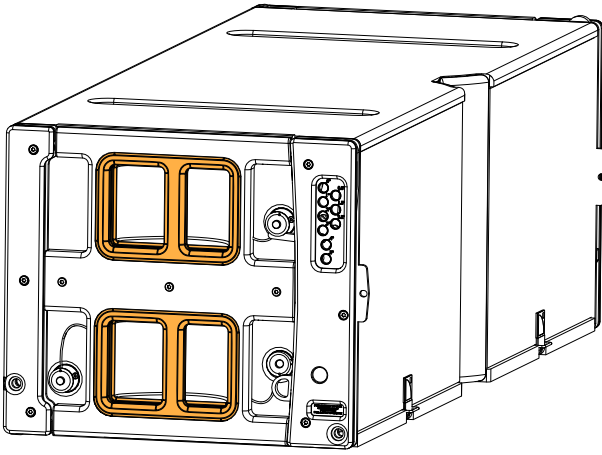

K1

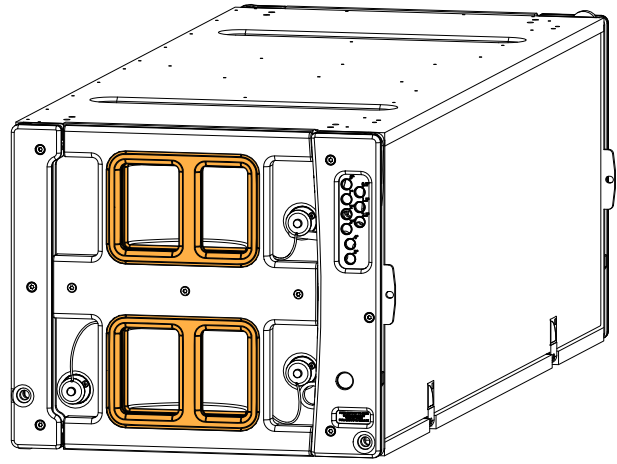

K1-SB

K1/K1-SB features two ground runners for enclosure protection. Two tracks on the top of the enclosure fit the ground runners in stacking deployment.

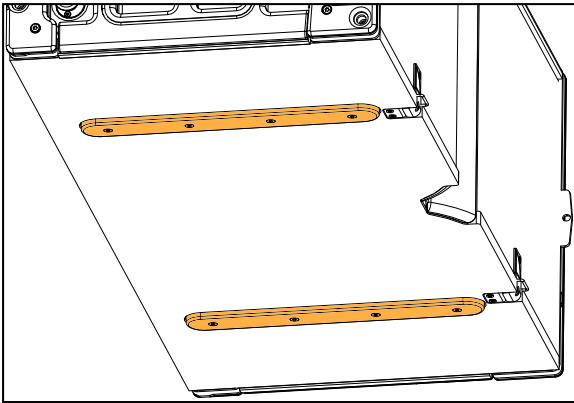

K1

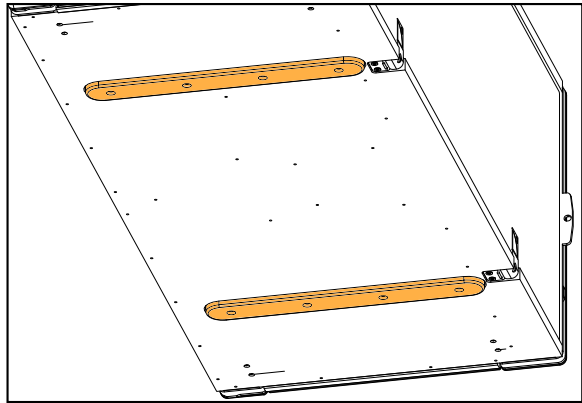

K1-SB

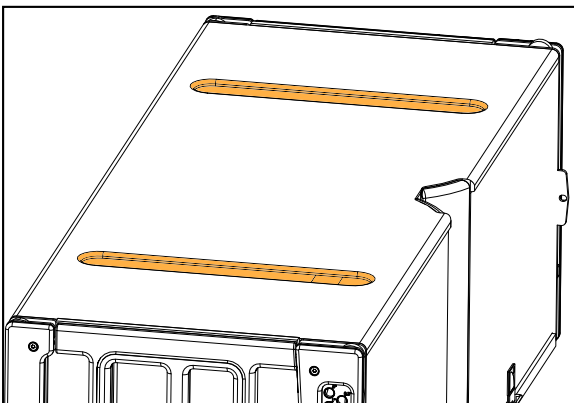

K1

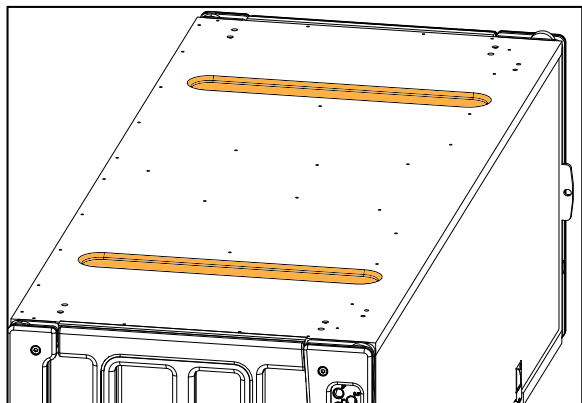

K1-SB

Rigging elements

K1-BUMP

K1-BUMP is a rigging frame designed for flying K1/K1-SB enclosure arrays. It features a central rigging bar with four \varnothing 22 mm shackles to secure security slings, K1-BPCHAIN and K1-DELTA.

K1-BUMP also features a support plate to accommodate a laser inclinometer. See [K1-BUMP](#) (p.140).

i An identification sticker is present at the front of K1-BUMP to identify the front and the rear sides.

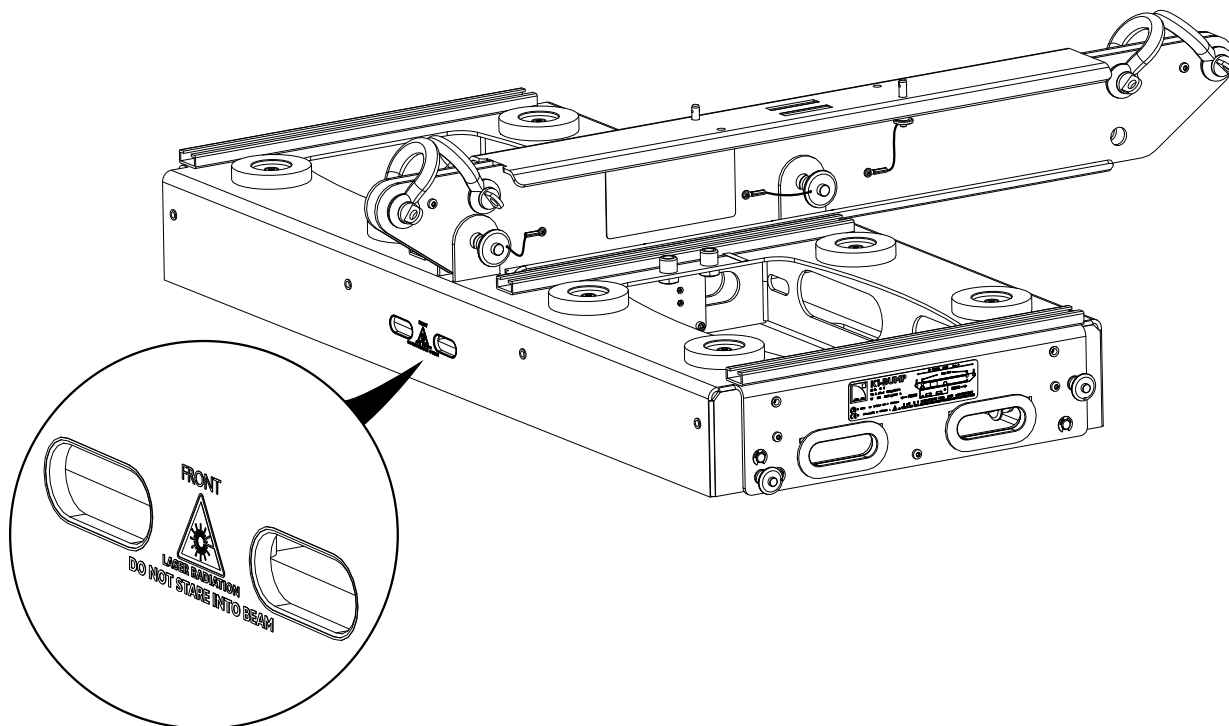

A rack stabilizer is available to mount LA-RAK II AVB touring racks.

Refer to [Preparing LA-RAK II AVB touring racks](#).

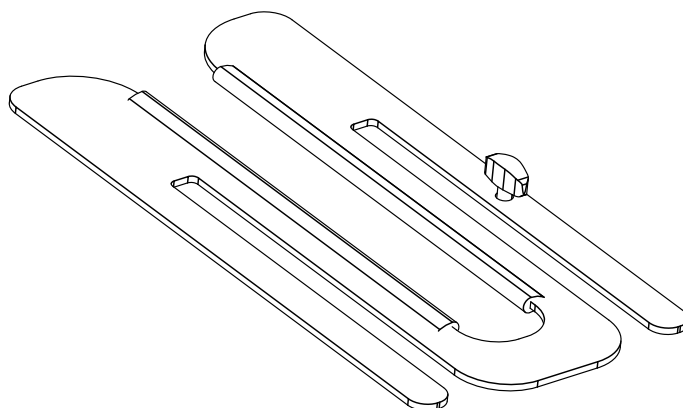

The central bar of K1-BUMP has two holes each for site angle adjustments. Adjust the central bar position for a front side or a rear overhang of the enclosure array.

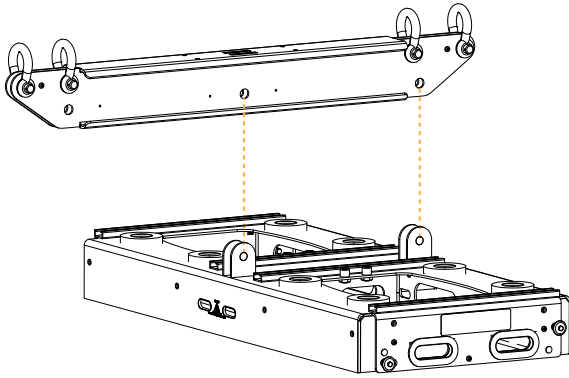

Front overhang

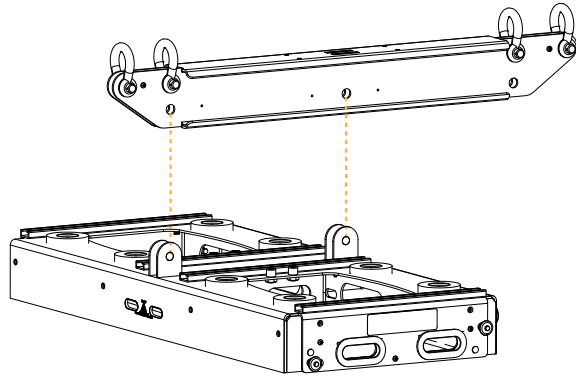

Rear overhang

The array site angle depends on the relative heights between the K1-BUMP's front and rear hang points (motor chain lengths) and central bar configuration (front or rear overhang).

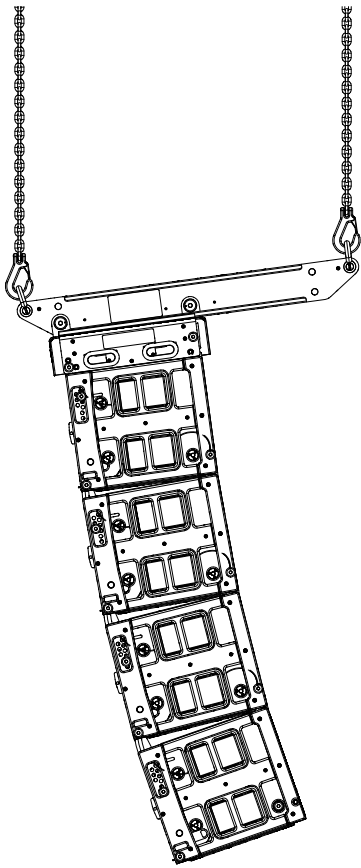

Rear overhang ($F > R$)

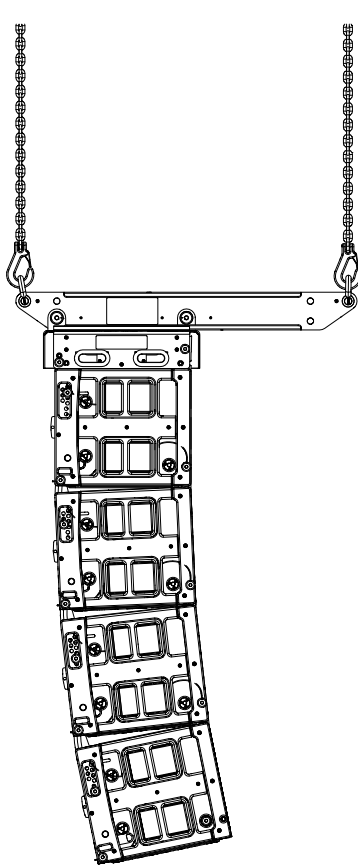

Rear overhang ($F = R$)

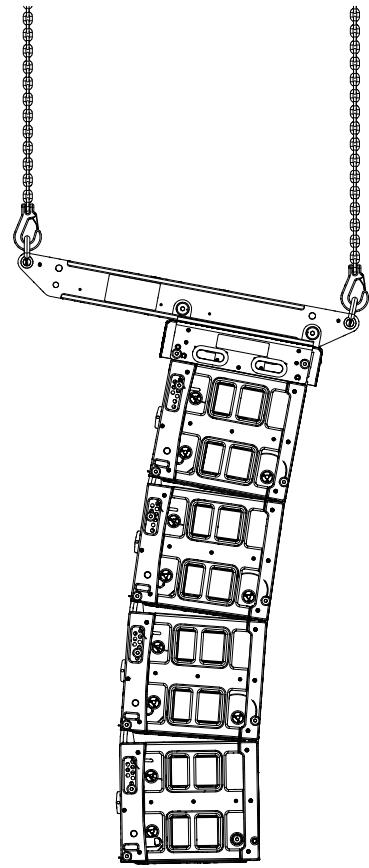

Front overhang ($F < R$)

K1-BPCHAIN is an adjustable extension chain compatible with K1-BUMP or K2-BUMP.

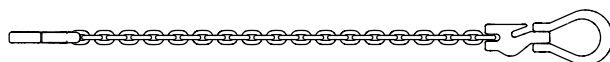

K1-BPCHAIN has a WLL (Working Load Limit) of 3.15 t and is necessary for climbing-hoist setup. It allows to prevent the chain bag from lying in front of the enclosures located on top of the array.

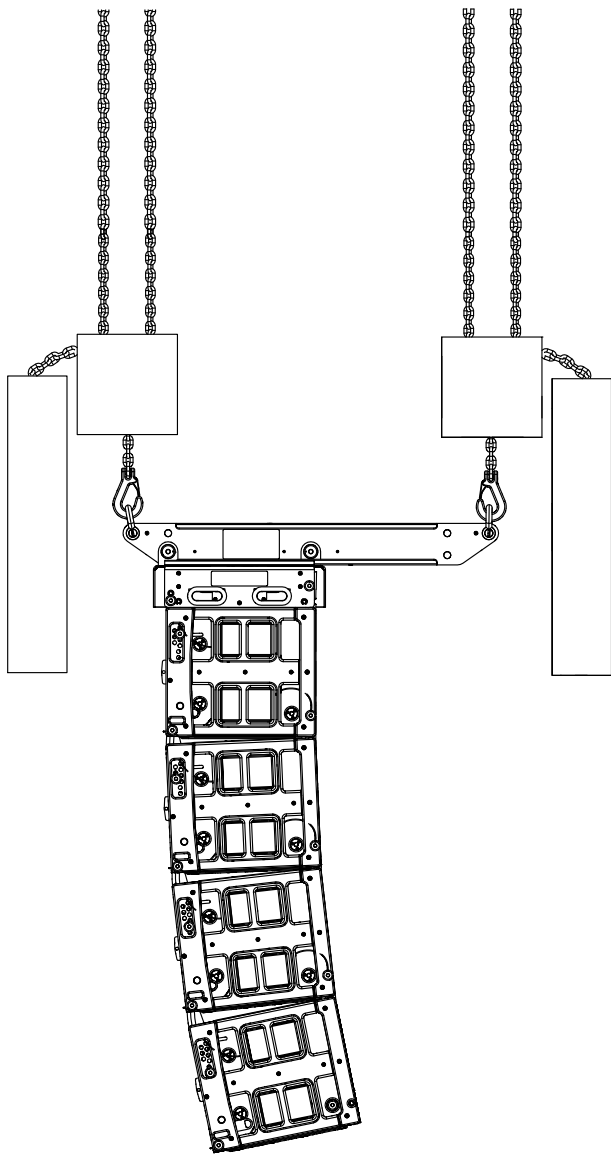

Without K1-BPCHAIN

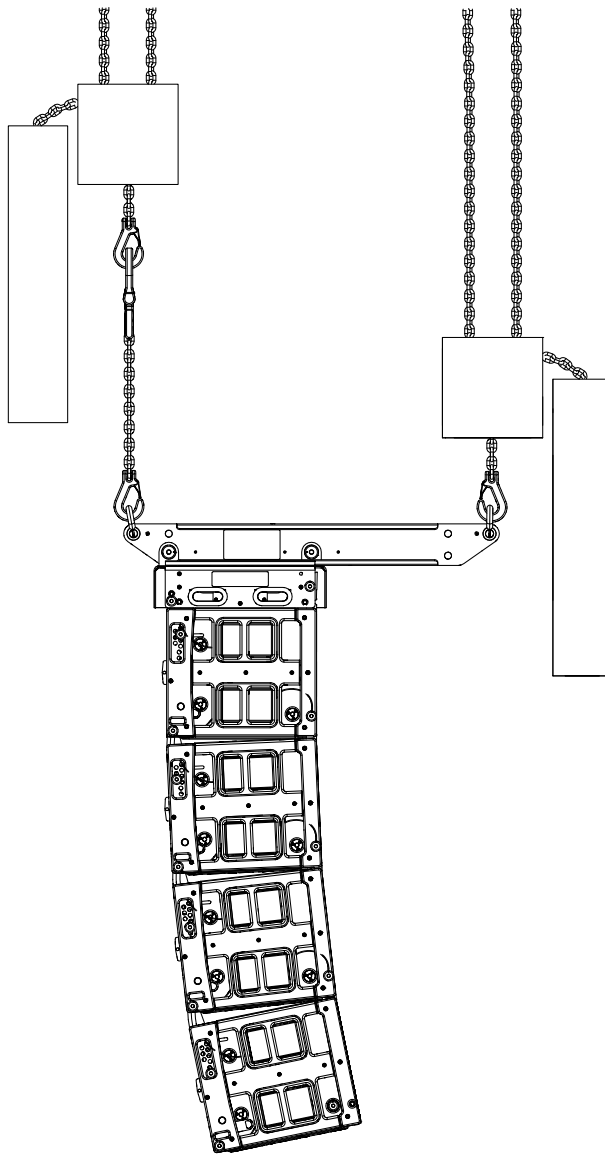

With K1-BPCHAIN

K1-DELTA

K1-DELTA is designed for azimuth angle setting.

Combined with K1-BUMP, K1-DELTA can be used to control the azimuth angle while K1-BUMP rigging bar controls the site angle.

The recommended space between the two lifting points is 1 m / 33 ft.

By adjusting the height of both pickup points, it is possible to adjust the azimuth angle from -10° to $+10^{\circ}$.

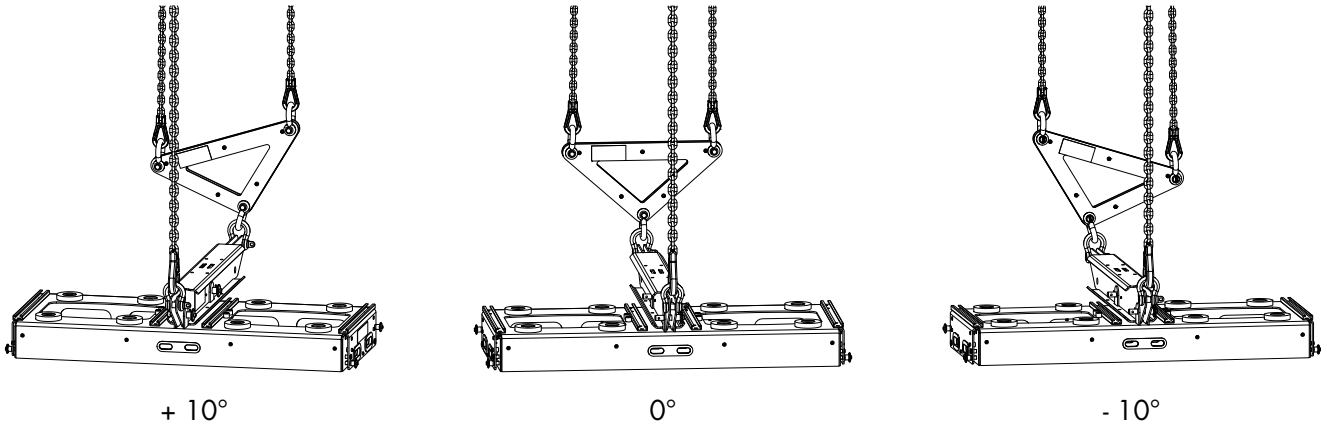

K1-LASERMOUNT

K1-LASERMOUNT is a support plate for mounting a laser inclinometer to the side of a K1 or K1-SB enclosure.

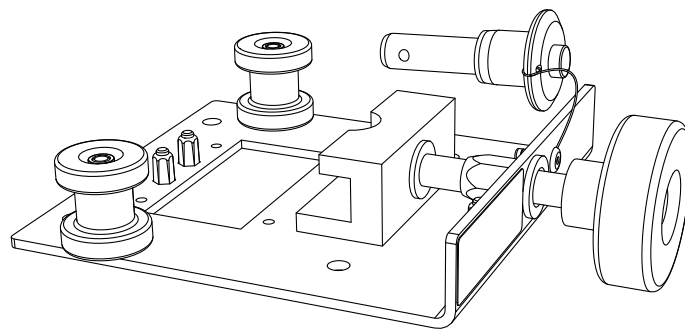

K1-LASERMOUNT is installed at the rear of the enclosure, on the right side.

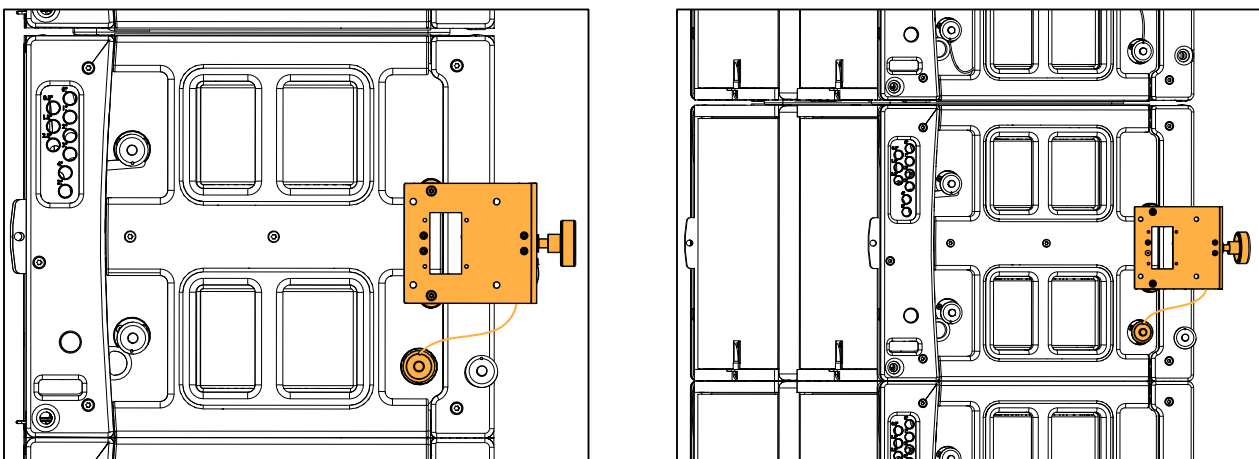

Refer to [Installing a laser inclinometer](#) (p.139).

KARA-DOWNK1

KARA-DOWNK1 is a rigging interface for Kara II under a K1 array. Refer to [Rigging a Kara II downfill array to the K1 array](#).

The four tabs on the top are compatible with the K1 rigging system. The four slits fitted with ball-locking pins accommodate the Kara II rigging arms.

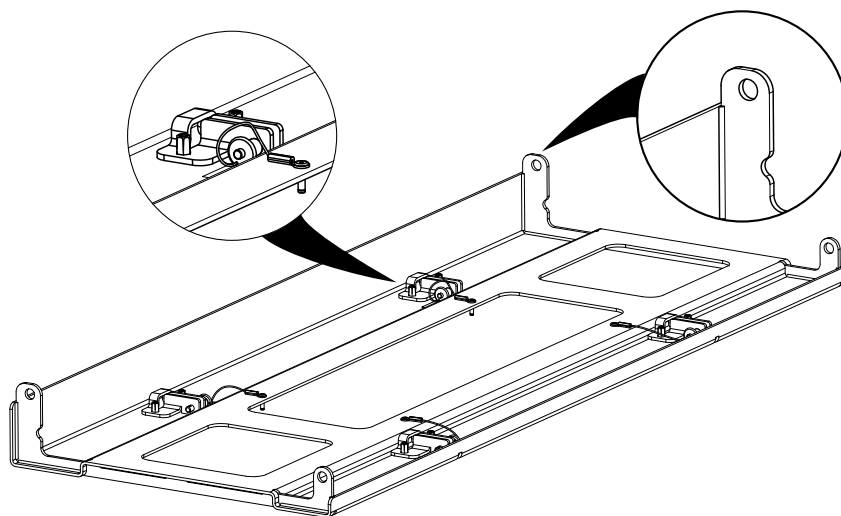

K2-LINK

K2-LINK is designed as an interface between the K1 and K2 rigging systems.

K2-LINK is used to hang K2 under K1, K1-SB, or K1-BUMP. Three holes at the top provide three angle settings between the top K2 enclosure and the bottom K1 element: 0.25°, 2.5°, and 5°.



To align the K2 and K1 element front faces, use the 0.25° hole.

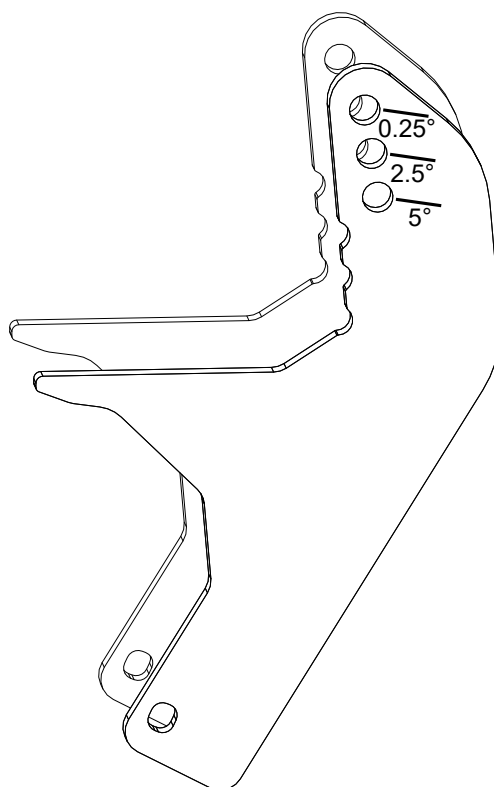

Transportation

K-BUMPFLIGHT

K-BUMPFLIGHT is a modular flight-case used to transport the accessories of the K1 system. It is designed to hook and lift K1-BUMP directly from the flight-case without any physical handling.

K-BUMPFLIGHT allows to transport up to two K1-BUMP and additional accessories in the removable tray:

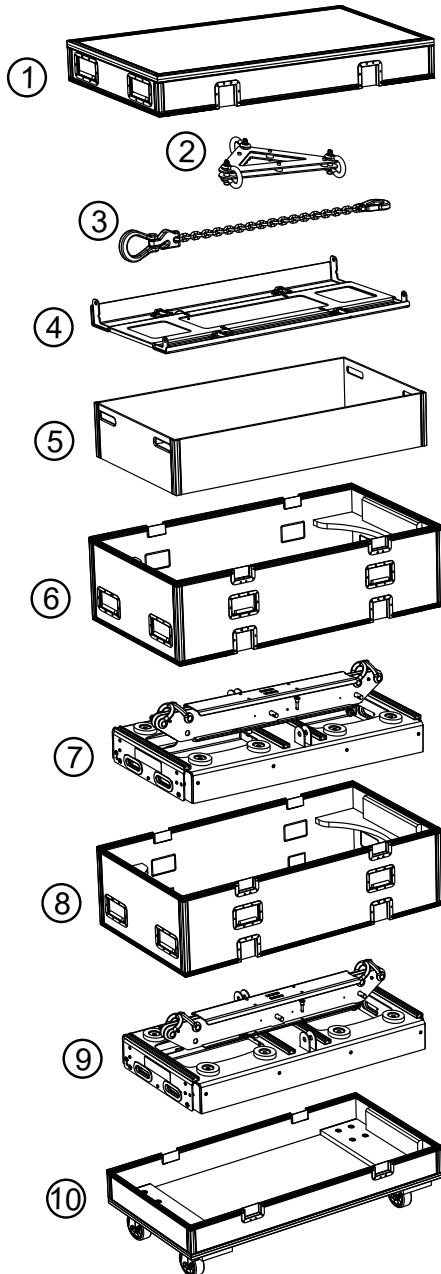

1. K-BUMPFLIGHT cover
2. K1-DELTA
3. K1-BPCHAIN
4. KARA-DOWNK1
5. Removable tray
6. Compartment
7. K1-BUMP
8. Compartment
9. K1-BUMP
10. Wheeled bottom tray

K-BUMPFLIGHT can also be fitted with two additional compartments. In that case, it can transport up to four K1-BUMP and additional accessories in the removable tray.

The total height of the flight-case with two additional compartments is equivalent to the height of an array of four K1 or K1-SB enclosures placed on a K1-CHARIOT.

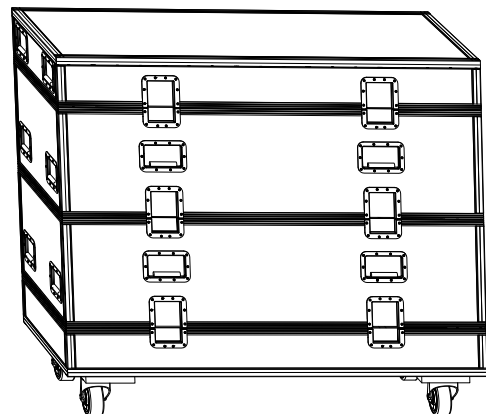

K1-CHARIOT

K1-CHARIOT is a chariot designed for the transportation and storage of blocks of up to four K1 or K1-SB.

! Do not move or transport more than four K1 or K1-SB on K1-CHARIOT.

! K1-CHARIOT is intended for use only with L-Acoustics K1 and K1-SB
 Use with other equipment may result in instability causing injury.

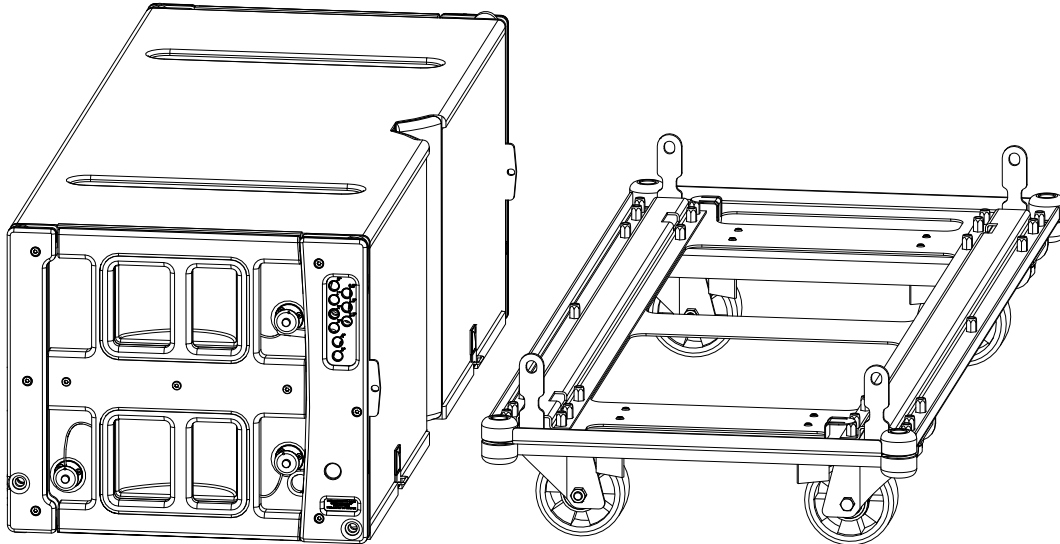

It features four rigging arms to secure the lower K1 or K1-SB.

i Enclosure can face either way.

! Risk of severe injury
 Remove all enclosures before performing any maintenance operation on K1-CHARIOT.

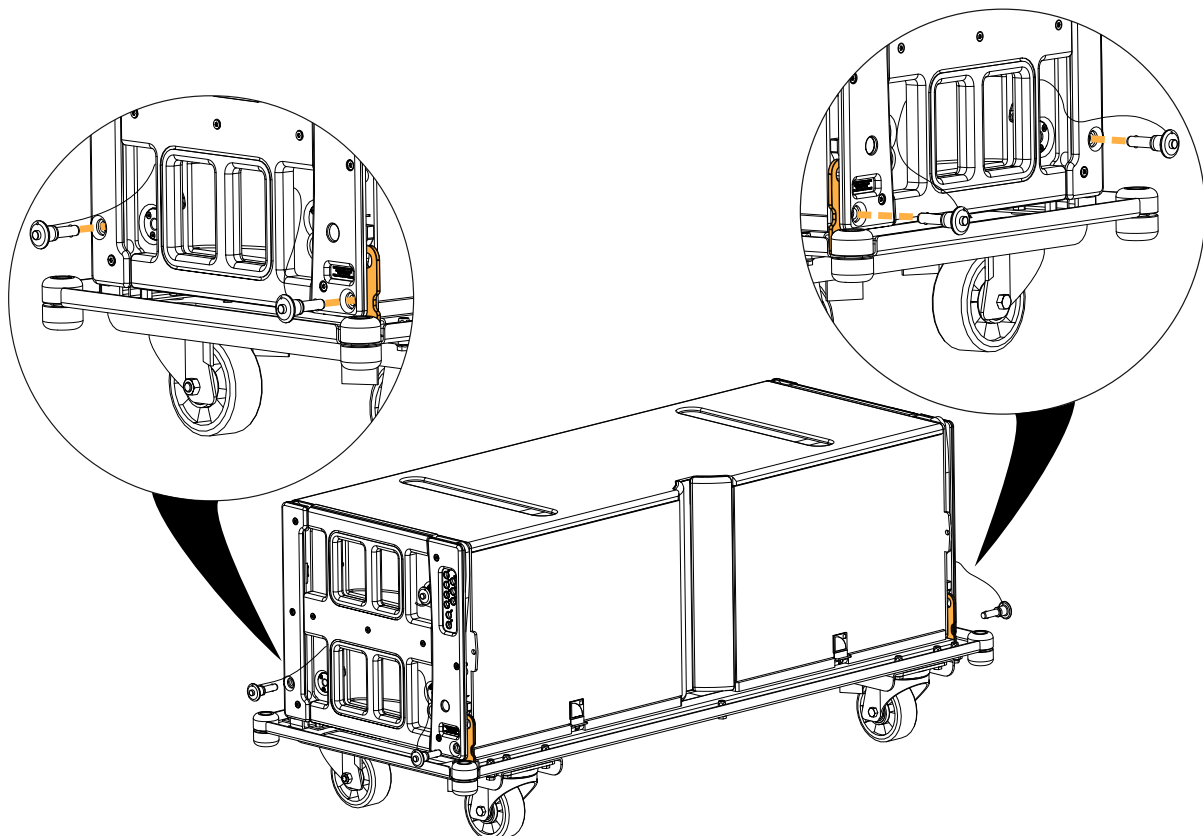

K1-PLA

K1-PLA is a dolly board that can be secured to the front of a K1 or K1-SB with two ball-locking pins.

⚠ K1-PLA is intended for use only with L-Acoustics K1 or K1-SB.
Use with other equipment may result in instability causing injury.

Two holes, at the front of K1 or K1-SB, are available to secure a K1-PLA.

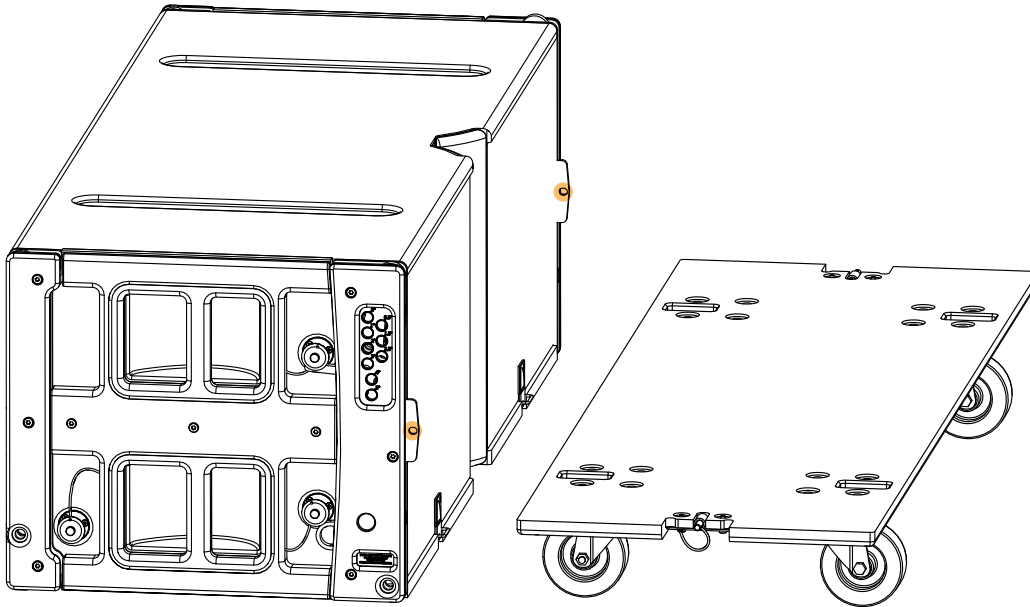

⚠ Use both K1-PLA ball-locking pins to secure K1.

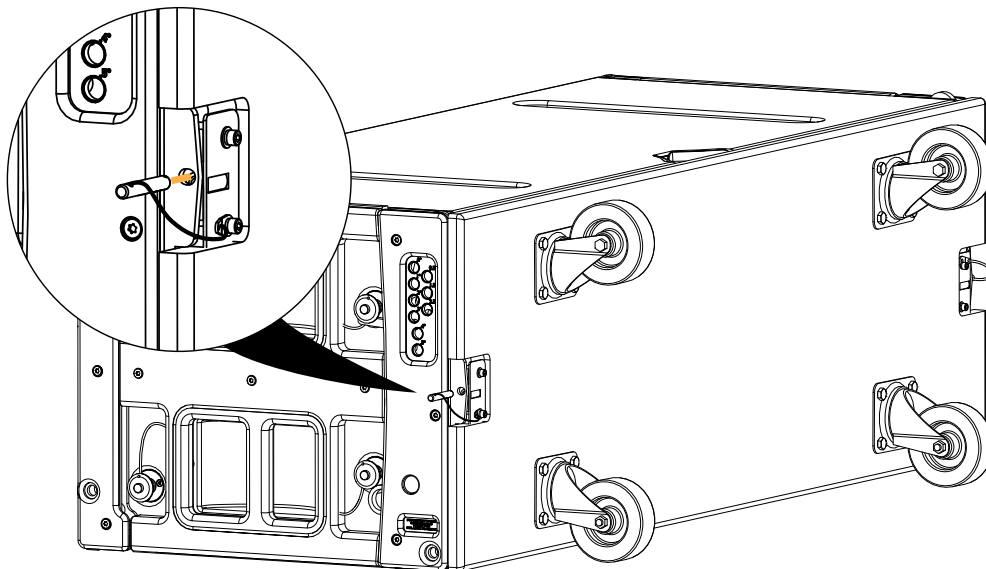

Multiple K1-PLA can be stacked for storage.

i Turn the wheels outwards to stack K1-PLA.

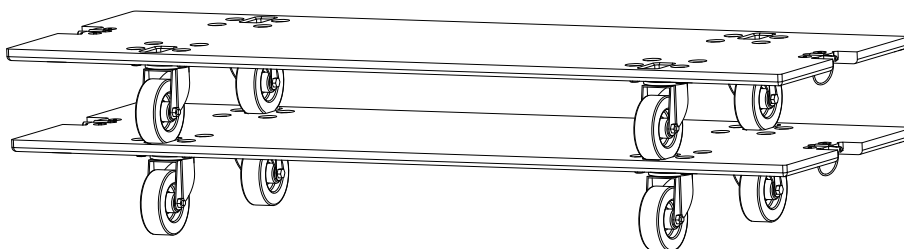

K1-CHARIOTCOV

K1-CHARIOTCOV is a protective cover for a stack of four K1 or K1-SB enclosures.

A zipper at the rear provides access to the connector plate of each enclosure.

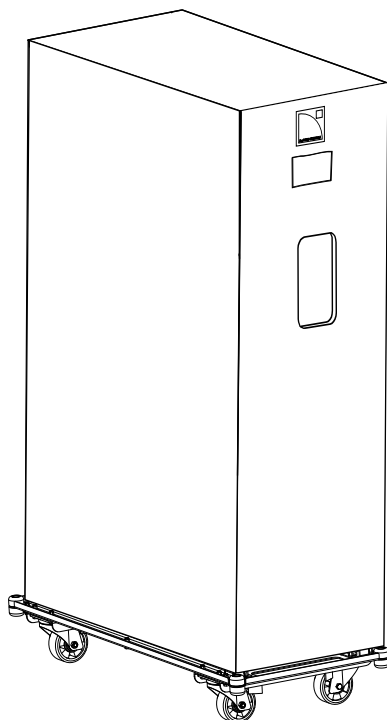

K1-COV/K1-SBCOV

K1-COV and K1-SBCOV are protective covers for one K1 or K1-SB enclosure on K1-PLA.

On each cover, a foldable flap provides access to the connector plate.

Foldable flap to access
the connectors

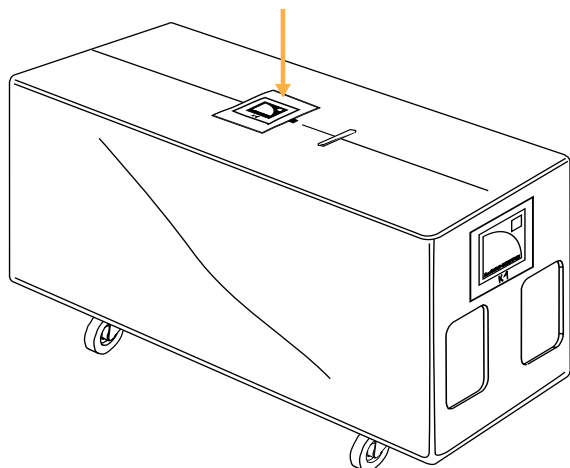

K1-COV

Foldable flap to access
the connectors

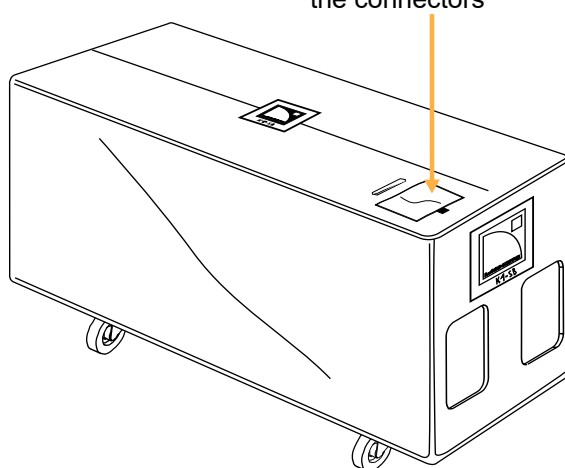

K1-SBCOV

Mechanical safety

Flown configurations

The K1 rigging system complies with 2006/42/EC: Machinery Directive. It has been designed following the guidelines of BGV-C1.

2006/42/EC: Machinery Directive specifies a safety factor of 4 against the rupture. The flown deployments described in this manual achieve a safety factor of **4 or more**.

Refer to Soundvision for the safety factor of a specific deployment.

The **safe limit** gives the maximum number of elements for which the safety factor is compliant with the 2006/42/EC: Machinery Directive, within the use defined in this manual and regardless of the other deployment parameters (site angles, inter-element angles, etc.).

The **maximum limit** gives the maximum number of elements for which the safety factor can be compliant with the 2006/42/EC: Machinery Directive, when the other deployment parameters provide the best mechanical conditions.

For mixed arrays refer to your Soundvision model.

 **Always refer to Soundvision for the safety factor of a mixed array.**
When flying a K1 array with a Kara II downfill, the mechanical safety of all system elements must be considered. The indicated maximum limit applies to the K1 only.

 **The site angle limits with LA-RAK II AVB on top of a K1 array are -20°/+20°.**

 **Do not implement a pullback on a K1 array with LA-RAK II AVB on top.**

 **Do not implement a pullback on a K1 array with a Kara II downfill.**

K1

configuration	rigging accessory	safe limit	maximum limit
flown	K1-BUMP	16	24
	K1-BUMP	14 K1 + 3 LA-RAK II AVB	23 K1 + 4 LA-RAK II AVB
flown with a downfill	KARA-DOWNK1	6 Kara II	

K1-SB

configuration	rigging accessory	safe limit	maximum limit
flown	K1-BUMP	20	24
	K1-BUMP	18 K1-SB + 3 LA-RAK II AVB	24 K1-SB + 4 LA-RAK II AVB

KS28

configuration	rigging accessory	maximum / safe limit
flown	KS28-BUMP	16

Other configurations

For other configurations, respect the recommended maximum limit for optimal stability.

K1

configuration	rigging accessory	safe limit	maximum limit
stacked	K1-CHARIOT	4	4

KS28

configuration	rigging accessory	maximum limit
ground-stacked	no rigging accessory or KS28-OUTRIG	4
stacked upright	no rigging accessory	2
stacked on chariot	KS28-CHARIOT	4

Assessing mechanical safety

Mechanical safety of the rigging system

Before any installation, always model the system in Soundvision and check the **Mechanical Data** section for any stress warning or stability warning.

In order to assess the actual safety of any array configuration before implementation, refer to the following warnings:

Rated working load limit (WLL) is not enough

The rated WLL is an indication of the element resistance to tensile stress. For complex mechanical systems such as loudspeaker arrays, WLLs cannot be used per se to determine the maximum number of enclosures within an array or to assess the safety of a specific array configuration.

Mechanical modeling with Soundvision

The working load applied to each linking point, along with the corresponding safety factor, will depend on numerous variables linked to the composition of the array (type and number of enclosures, splay angles) and the implementation of the flying or stacking structure (number and location of flying points, site angle). This cannot be determined without the complex mechanical modeling and calculation offered by Soundvision.

Assessing the safety with Soundvision

The overall safety factor of a specific mechanical configuration always corresponds to the lowest safety factor among all the linking points. Always model the system configuration with the Soundvision software and check the **Mechanical Data** section to identify the weakest link and its corresponding working load. By default, a stress warning will appear when the mechanical safety goes beyond the recommended safety level.

Safety of ground-stacked arrays in Soundvision

For ground-stacked arrays, a distinct stability warning is implemented in Soundvision. It indicates a tipping hazard when the array is not secured to the ground, stage or platform. It is the user's responsibility to secure the array and to ignore the warning.

Additional safety for flown arrays

When flying an array, use available holes to implement a secondary safety.

Considerations must be given to unusual conditions

Soundvision calculations are based on usual environmental conditions. A higher safety factor is recommended with factors such as extreme high or low temperatures, strong wind, prolonged exposition to salt water, etc. Always consult a rigging specialist to adopt safety practices adapted to such a situation.

Loudspeaker configurations

Line source

Deployed as a line source, the system operates over the nominal bandwidth of the K1 enclosure.

Two configurations are possible:

- K1 line source
- K1/K1-SB line source: enhanced LF throw

By providing the K1-SB with the same frequency response as the K1 low section, the [K1SB_X] preset allows the K1-SB enclosure to be used as an LF line source element, increasing the length of the sub-low line source.

The K1 and K1-SB enclosures are driven by the LA12X amplified controllers.

Standalone K1 line source

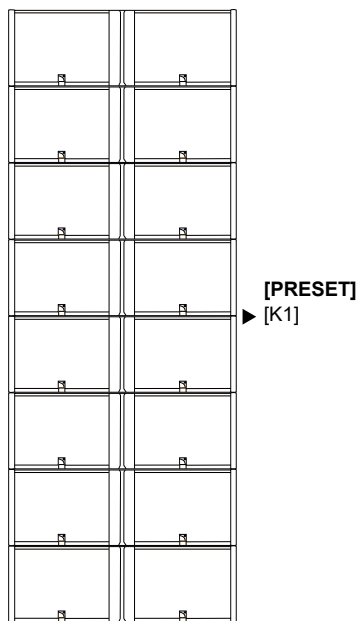

Enclosure	K1
Preset	[K1]
Frequency range (-10 dB)	35 Hz - 20 kHz

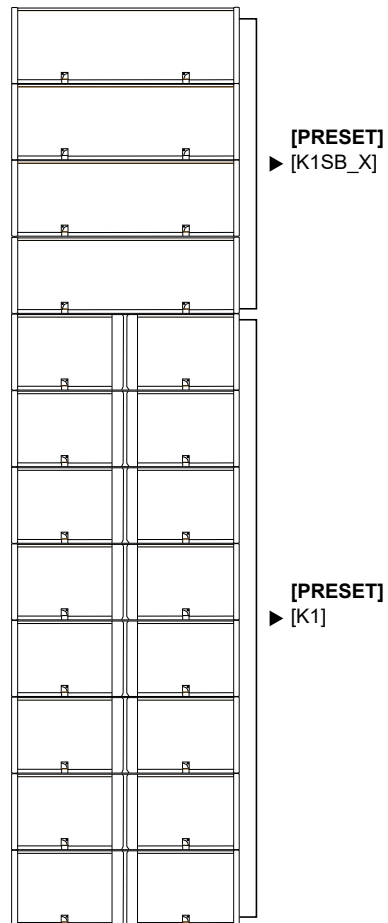
K1/K1-SB line source

Enclosure	K1	K1-SB
Preset	[K1]	[K1SB_X]
Frequency range (-10 dB)	35 Hz - 20 kHz	
Recommended ratio	2 K1 : 1 K1-SB	
Minimum line length	8 K1 + 4 K1-SB	

! When using [K1] with [K1SB_X], do not add any delay value between the K1 and K1-SB elements of a same line source.

K1-SB applications

There are two distinct applications for K1-SB in a K1 system:

- As an LF extension in a line source for enhanced throw, using the [K1SB_X] preset with K1.
- As a subwoofer for increased impact, using the [K1SB_60] preset.

i Both applications of K1-SB can be combined in the same configuration.

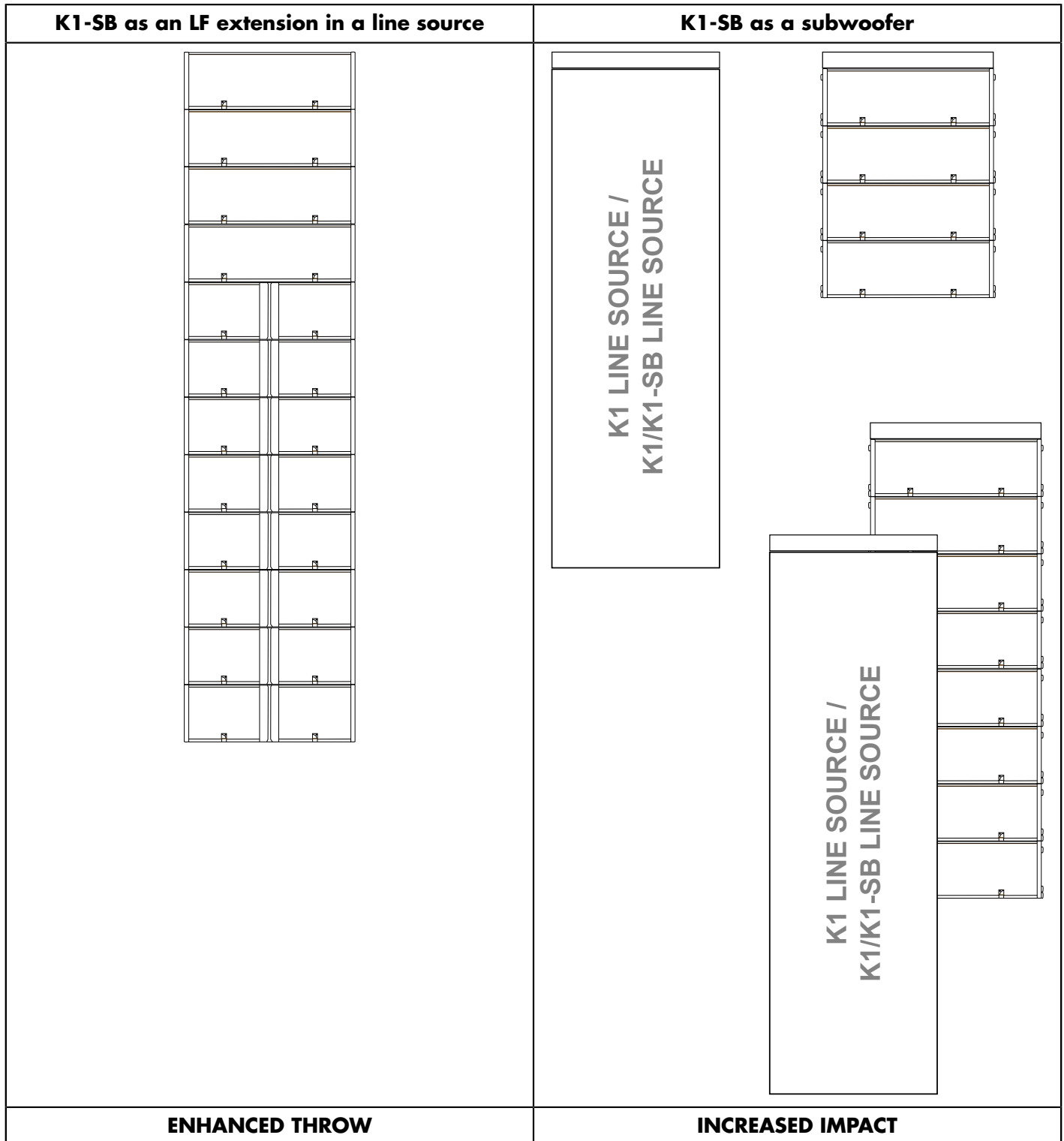

Additional subwoofer system

A K1 line source or a K1/K1-SB line source can be deployed with additional subwoofer enclosures to provide increased sub-low resources to demanding applications.

Two subwoofer systems are available:

- K1-SB for increased impact
- KS28 for infra extension

The recommended ratio is one K1 for one subwoofer, whether using K1-SB subwoofers only, KS28 subwoofers only, or a combination of both. The [K1SB_60] and [KS28_60] presets provide the subwoofers with an upper frequency limit at 60 Hz for an optimal frequency coupling with the line source.

K1-SB and KS28 are driven by the LA12X amplified controller.

K1-SB

K1-SB provides an extension of the bandwidth in the low end, down to 30 Hz. Depending on the deployment, LF rejection can be produced. Two deployments are available in this configuration:

- K1-SB beside the K1 or K1/K1-SB line source: side LF rejection (polarized)
- K1-SB behind the K1 or K1/K1-SB line source: rear LF rejection (cardioid)

Line source with K1-SB beside

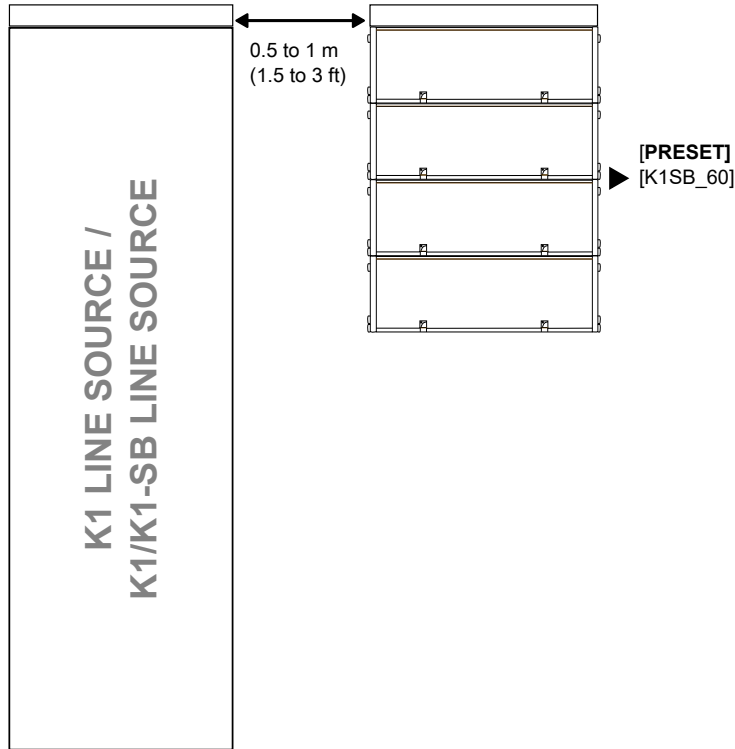

Enclosure	K1	K1-SB in line source	K1-SB as subwoofer
Preset	[K1]	[K1SB_X]	[K1SB_60]
Frequency range (-10 dB)	30 Hz - 20 kHz		
Recommended ratio	1 K1 : 1 subwoofer		
Recommended distance between front panels	Between 0.5 m (1.5 ft) and 1 m (3 ft)		

! Delay values

Do not forget to add the pre-alignment and geometric delays depending on the configuration.

! When using [K1] with [K1SB_X], do not add any delay value between the K1 and K1-SB elements of a same line source.

Pre-alignment delays

presets	pre-alignment delay values and polarity settings	
[K1] + [K1SB_60]	K1 = 6 ms <input style="float: right;" type="button" value="+"/>	K1-SB = 0 ms <input style="float: right;" type="button" value="+"/>

Line source with K1-SB behind

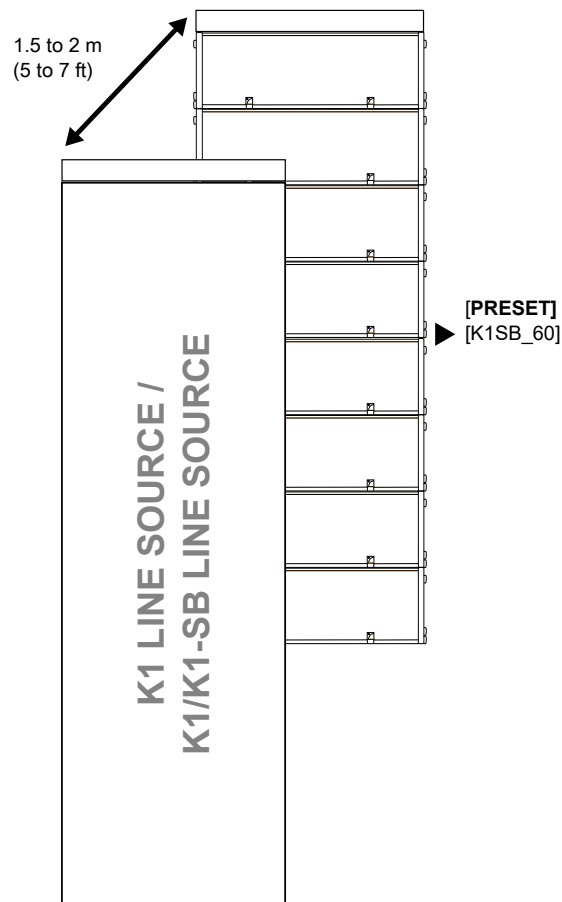

Enclosure	K1	K1-SB in line source	K1-SB as subwoofer
Preset	[K1]	[K1SB_X]	[K1SB_60]
Frequency range (-10 dB)	30 Hz - 20 kHz		
Recommended ratio	1 K1 : 1 subwoofer		
Recommended distance between front panels	Between 1.5 m (5 ft) and 2 m (7 ft)		

! Delay values

Do not forget to add the pre-alignment and geometric delays depending on the configuration.

! When using [K1] with [K1SB_X], do not add any delay value between the K1 and K1-SB elements of a same line source.

Pre-alignment delays

K1 + K1-SB

presets	pre-alignment delay values and polarity settings	
[K1] + [K1SB_60]	K1 = 6 ms <input type="checkbox"/>	K1-SB = 0 ms <input type="checkbox"/>

Geometric delays

1.5 m (5 ft)	Line source = 4.5 ms
2 m (7 ft)	Line source = 6 ms

KS28

The KS28 provides an extension of the bandwidth in the low end, down to 25 Hz.

Line source with KS28

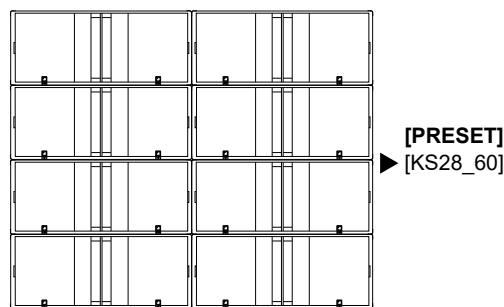

Enclosure	K1	K1-SB in line source	KS28
Preset	[K1]	[K1SB_X]	[KS28_60]
Frequency range (-10 dB)	25 Hz - 20 kHz		
Recommended ratio	1 K1 : 1 subwoofer		

- ! Grouping subwoofers**
Place the subwoofer enclosures side by side. If not possible, the maximum distance between two adjacent acoustic centers must be 2.8 m (9.2 ft) or 1.7 m (5.6 ft) if the upper frequency limit of the subwoofer system is at 60 Hz or 100 Hz, respectively.
- ! Use [xxxx_xx_C] or [xxxx_xx_Cx] on a reversed subwoofer in a cardioid configuration**
The cardioid configuration consists in reversing 1 element in an array of 4 subwoofers.
Refer to the subwoofer owner's manual and to the **Cardioid configurations** technical bulletin.
- ! Delay values**
Do not forget to add the pre-alignment and geometric delays depending on the configuration.
- ! When using [K1] with [K1SB_X], do not add any delay value between the K1 and K1-SB elements of a same line source.**

Pre-alignment delays**K1 + KS28**

presets	pre-alignment delay values and polarity settings			
[K1] + [KS28_60]	K1 = 0.5 ms	<input type="checkbox"/>	KS28 = 0 ms	<input type="checkbox"/>
[K1] + [KS28_60_C]	K1 = 6 ms	<input type="checkbox"/>	KS28 = 0 ms	<input type="checkbox"/>
[K1] + [KS28_60_Cx]	K1 = 4 ms	<input type="checkbox"/>	KS28 = 0 ms	<input type="checkbox"/>

K1 + K1-SB + KS28

presets	pre-alignment delay values and polarity settings					
[K1] + [K1SB_X] + [KS28_60]	K1 = 0 ms	<input type="checkbox"/>	K1-SB = 0 ms	<input type="checkbox"/>	KS28 = 0 ms	<input type="checkbox"/>
[K1] + [K1SB_X] + [KS28_60_C]	K1 = 5.5 ms	<input type="checkbox"/>	K1-SB = 5.5 ms	<input type="checkbox"/>	KS28 = 0 ms	<input type="checkbox"/>
[K1] + [K1SB_X] + [KS28_60_Cx]	K1 = 3.5 ms	<input type="checkbox"/>	K1-SB = 3.5 ms	<input type="checkbox"/>	KS28 = 0 ms	<input type="checkbox"/>

Additional downfill element

All K1 system configurations can be combined with an additional Kara II or K2 line source downfill system. This allows an extension of the vertical coverage to the closer audience.

Kara II

The [KARAIIDOWNK1], [KARAIIDOWNK1 70] and [KARAIIDOWNK1 90] presets feature a high-pass filter at 55 Hz for the low section, along with specific delay settings, in order to optimize the acoustic coupling between the Kara II and K1 line sources.

The Kara II enclosure is driven by the LA4X / LA12X amplified controllers.



The [KARAIIDOWNK1] preset is optimized for a **110°** fins setting on Kara II.



Fins settings for downfill



In most venues, the 110° fins settings must be used for downfills.

In case there is a raised area in front of the scene, such as a catwalk, the 70° or 90° settings can be used to divert SPL from this area.

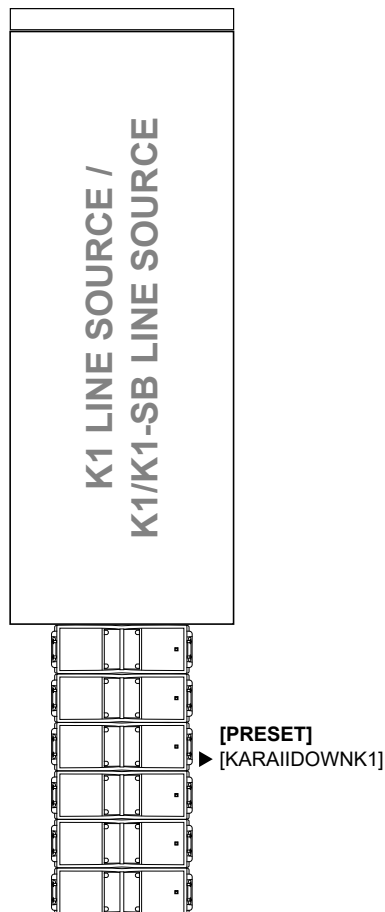
Line source with Kara II downfill system



Enclosure	K1	K1-SB in line source	Kara II
Preset	[K1]	[K1SB_X]	[KARAIIDOWNK1] [KARAIIDOWNK1 70] [KARAIIDOWNK1 90]
Frequency range (-10 dB)	35 Hz - 20 kHz		
Kara II array	Up to 6 Kara II enclosures		

-  Do not add any delay between the K1 and Kara II elements of a mixed line source.
-  When using [K1] with [K1SB_X], do not add any delay value between the K1 and K1-SB elements of a same line source.
-  **Using the Kara II system**
Refer to the **Kara II owner's manual** for the operating modes of Kara II as a main system.

K2

The [K2 110] preset provides K2 with the same horizontal coverage as K1 for optimal downfill.

The K2 enclosure is driven by the LA4X / LA12X amplified controller.

i Fins settings for downfill

In most venues, the 110° fins settings must be used for downfills.

In case there is a raised area in front of the scene, such as a catwalk, the 70° or 90° settings can be used to divert SPL from this area.

Line source with K2 downfill system

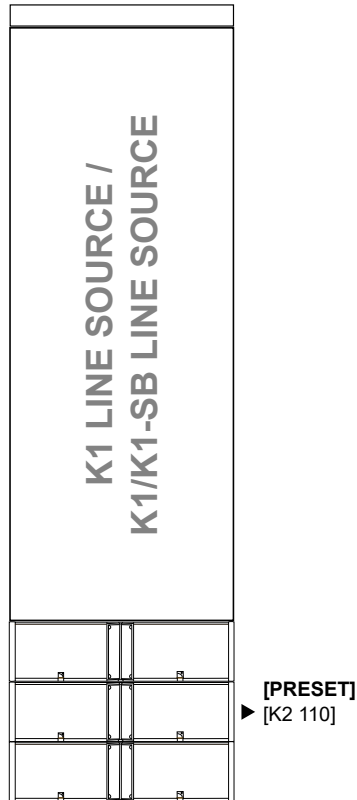

Enclosure	K1	K1-SB in line source	K2
Preset	[K1]	[K1SB_60]	[K2 70][K2 90][K2 110]
Frequency range (-10 dB)	35 Hz - 20 kHz		

- !** Do not add any delay between the K1 and K2 elements of a mixed line source.
- !** When using [K1] with [K1SB_X], do not add any delay value between the K1 and K1-SB elements of a same line source.
- i** **Using the K2 system**
Refer to the **K2 owner's manual** for the operating modes of K2 as a main system.

Inspection and preventive maintenance

How to do preventive maintenance

Inspect the system before any deployment and after any corrective maintenance operation.

Perform preventive maintenance at least once a year.

Rigging and hardware

Perform the [Rigging part inspection](#) (p.42) on each rigging part.

Use the [Mechanical system overview](#) (p.43) to identify critical parts of the system and apply the specific checks described in the [Inspection references](#) (p.49).

Do the [Rigging check](#) (p.52).

If any parts are damaged, contact your L-Acoustics representative for further instructions.

Acoustics

Perform the [Enclosure check](#) (p.58).

Perform the [Listening test](#) (p.60) to detect any degradation in sound quality.

If necessary, refer to the [Corrective maintenance](#) (p.106) section for speaker repair kits and maintenance instructions.

Rigging part inspection

About this task

For critical rigging parts, use the [Inspection references](#) (p.49) for comparison and specific manipulations.

The term "rigging part" comprises:

- lifting accessories such as clamps and shackles
- rigging accessories such as rigging frames, rigging interfaces, and brackets
- fasteners used for assembling two products together such as ball-locking pins, rigging axes, and safety pins
- rigging elements integrated in the product such as rigging arms and rails
- transportation accessories

This inspection procedure covers only L-Acoustics products. To inspect other products that are part of the lifting chain, refer to the manufacturer's instructions.

Prerequisite

Perform the inspection in a well-lit environment.

Procedure

1. Check that the rigging part is present.
2. If applicable, disassemble the rigging part from the enclosure or the rigging accessory.

Check that the tethers are intact and safely secured.

3. Inspect the part from every side.

Compare with the **reference pictures**.

Check for:

- corrosion
- wear and cracks
- bends and dents
- holes
- missing safety cues
- missing identification labels
- missing or loose fasteners



Replacing screws

If a screw is loose, remove and replace it.

Always use the new screws provided in the repair kit.

If no new screw is available, add blue threadlocker before reusing the screw.

Do not apply more than the indicated torque.

4. Check the **geometry** of the part to identify critical deformations.

Place the rigging part on a flat surface or hold a level against it.

5. Check the **moving parts**.



Make sure that the mechanism engages correctly.

What to do next

If a problem is detected, perform the authorized maintenance operations or contact your L-Acoustics representative.

Mechanical system overview

Critical parts of the lifting chains are highlighted.

The  indicates a visual inspection. The  indicates a functional check.

 Perform the [Rigging part inspection](#) (p.42) on critical parts.
For each part, refer to the [Inspection references](#) (p.49).

 **Replacing screws**
If a screw is loose, remove and replace it.
Always use the new screws provided in the repair kit.
If no new screw is available, add blue threadlocker before reusing the screw.
Do not apply more than the indicated torque.

K1 mixed array with K1-BUMP and K1-SB

Refer to [Inspection references](#) (p.49).

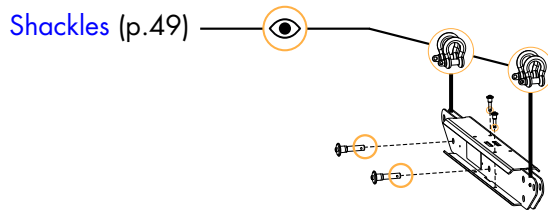

Shackles (p.49)

Ball-locking pins (p.49)

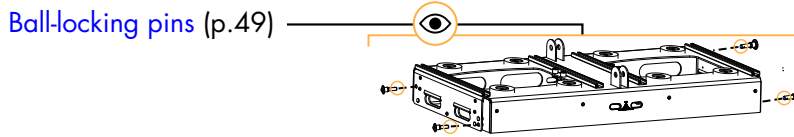

Ball-locking pins (p.49)

- Rear rigging arms rotate correctly
- Front rigging arms slide correctly

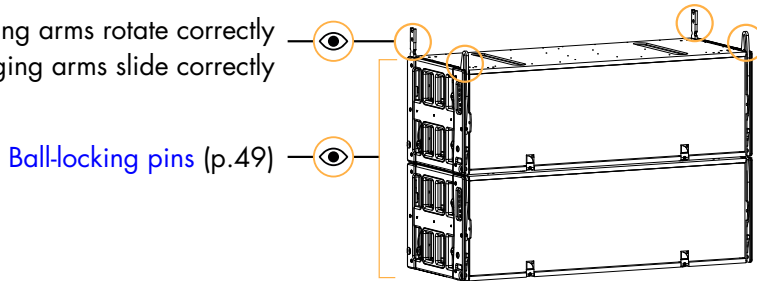

Ball-locking pins (p.49)

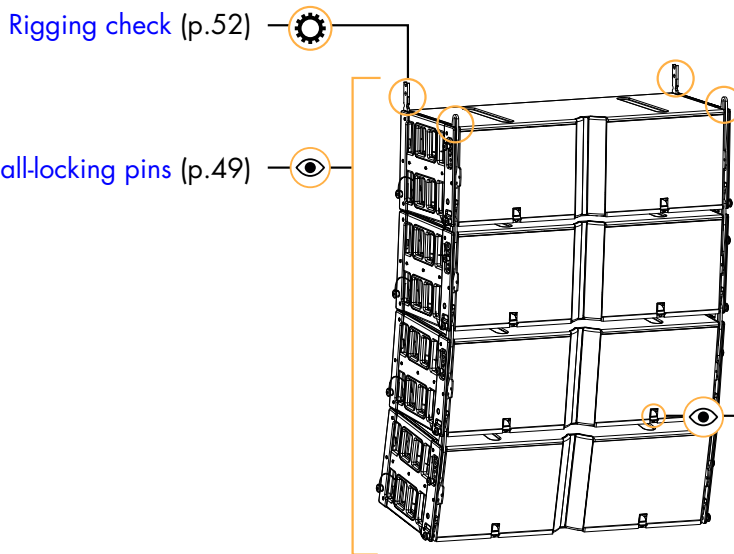

Rigging check (p.52)

Ball-locking pins (p.49)

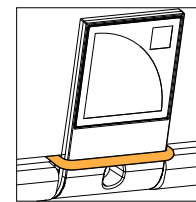

Grill safety

K1 array with K1-BUMP, KARA-DOWNK1 and Kara II

Refer to [Inspection references](#) (p.49).

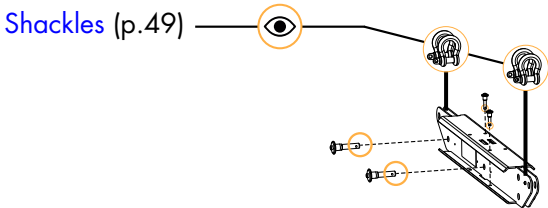

Shackles (p.49)

Ball-locking pins (p.49)

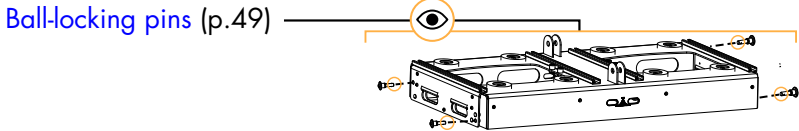

Ball-locking pins (p.49)

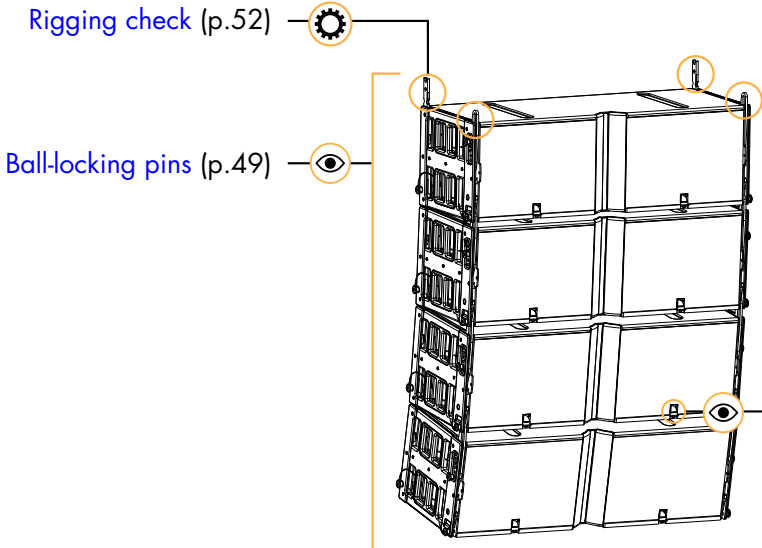

Rigging check (p.52)

Ball-locking pins (p.49)

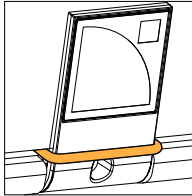

Grill safety

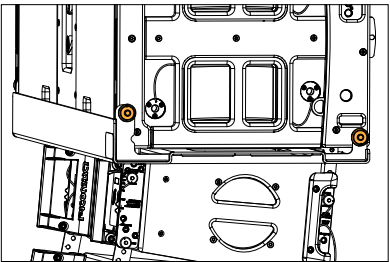

Ball-locking pins (p.49)

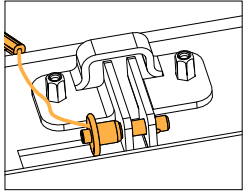
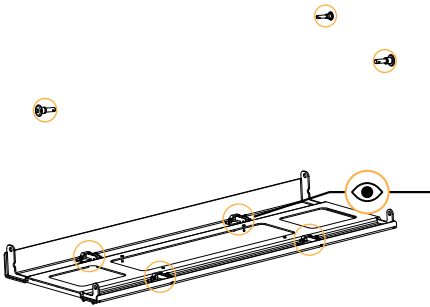

Ball-locking pins (p.49)

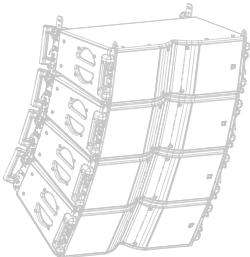

Refer to the **Kara II owner's manual** for more information.

K1 array with K1-CHARIOT

Refer to [Inspection references](#) (p.49).

Rigging check (p.52)



Ball-locking pins (p.49)

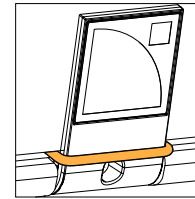
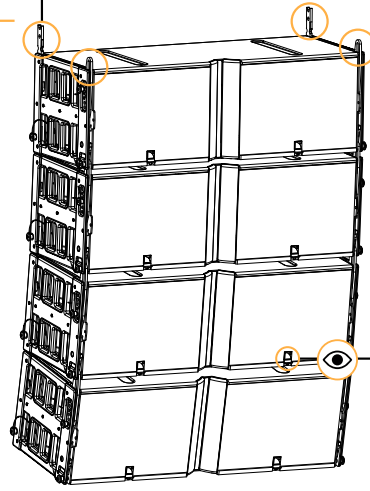

Grill safety

Rigging check (p.52)



K1 array with K1-BUMP and LA-RAK II AVB

Refer to [Inspection references](#) (p.49).

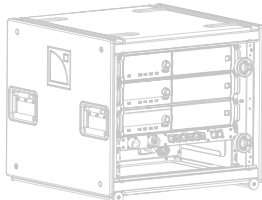

Refer to the **LA-RAK II AVB owner's manual** for more information.

Shackles (p.49)

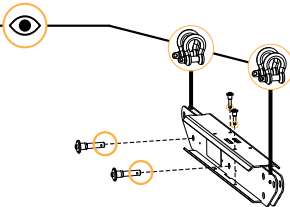

Ball-locking pins (p.49)

Ball-locking pins (p.49)

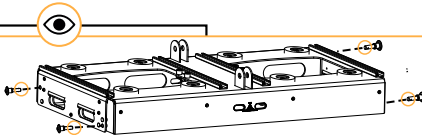

Rigging check (p.52)



Ball-locking pins (p.49)

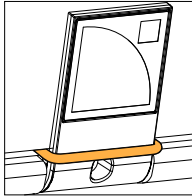
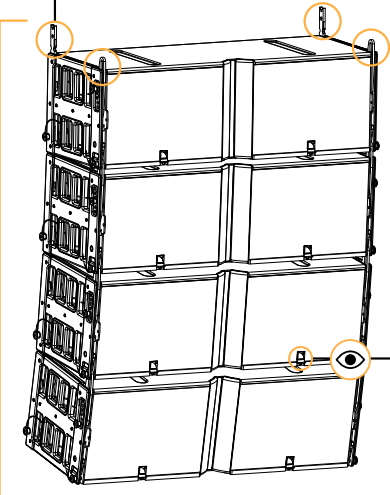

Grill safety

K2 mixed array with K1-BUMP, K1-SB, and K2-LINK

Refer to [Inspection references](#) (p.49).

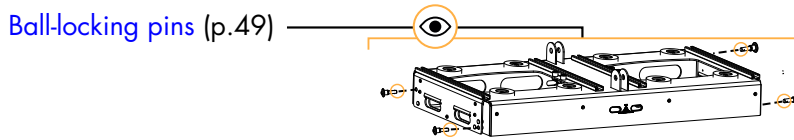
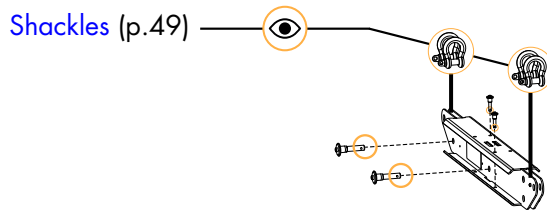

- Rear rigging arms rotate correctly
- Front rigging arms slide correctly

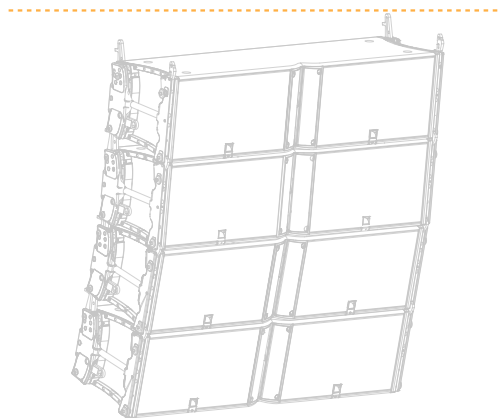
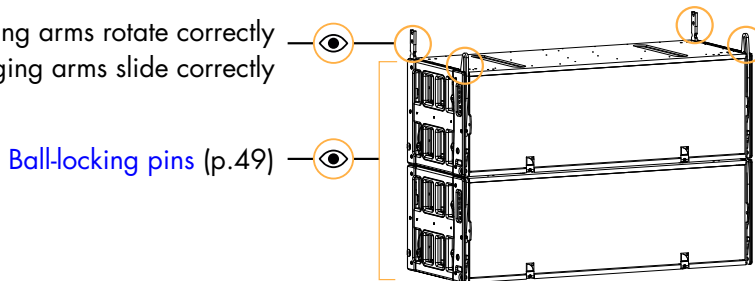

Refer to the **K2 owner's manual** for more information.

Inspection references

Shackles

Moving parts

Drive the shackle axis in its lodging. Make sure that the end is flush with the shackle.

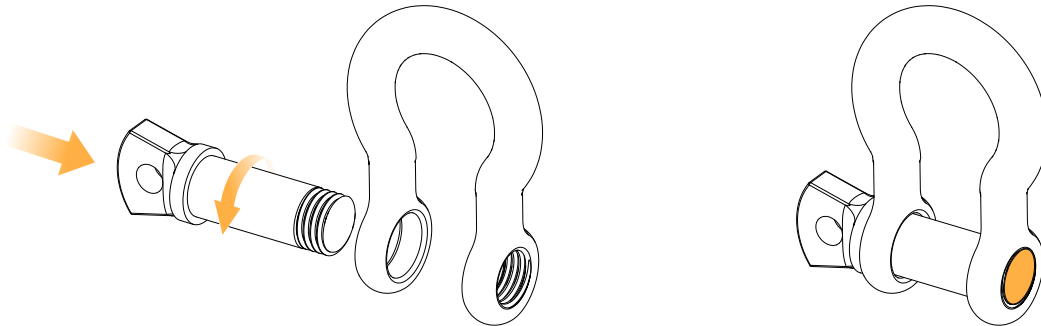

Related tasks

[Rigging part inspection](#) (p.42)

Ball-locking pins

Reference pictures

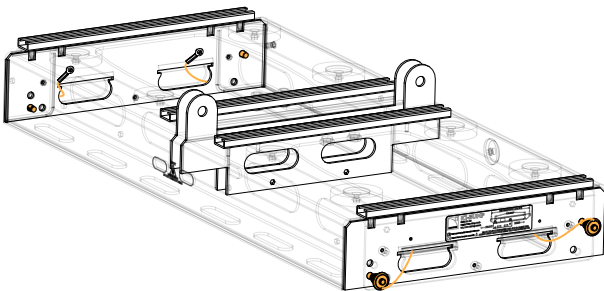

tether (K1-BUMP)

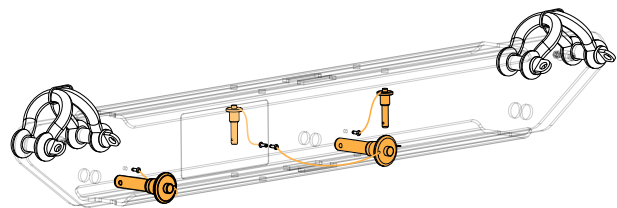

tether (K1-BUMP rigging bar)

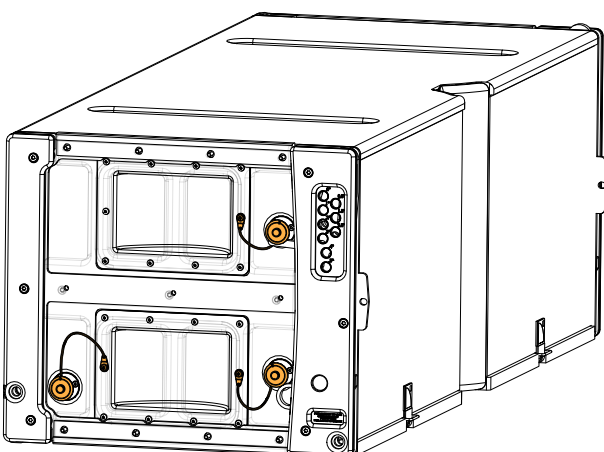

tether (K1)

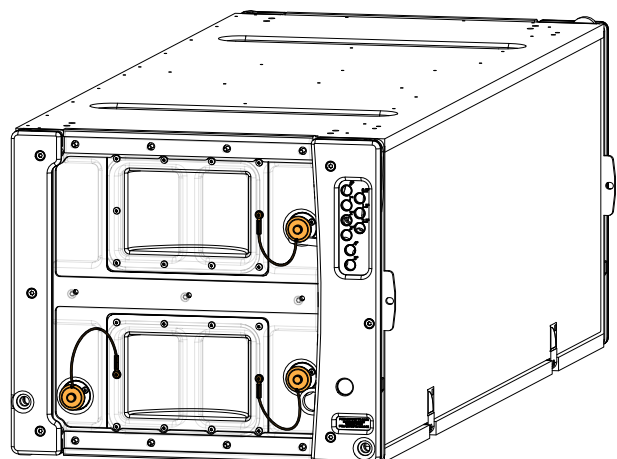

tether (K1-SB)

Moving parts

1. Press the push button. The ball-locking mechanism is retracted.
2. Release the button. The ball-locking mechanism is activated.

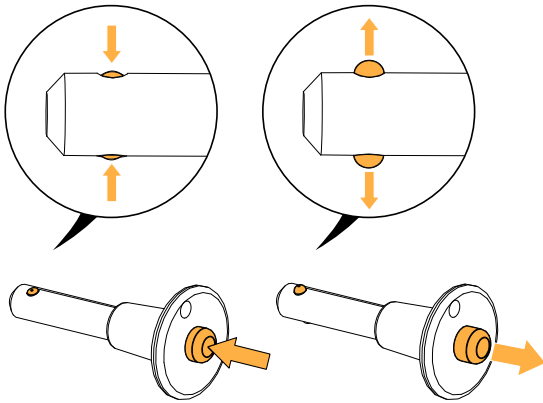

3. Insert the pin in each storage and rigging hole. Pull and rotate the pin. The pin must remain inside the hole.

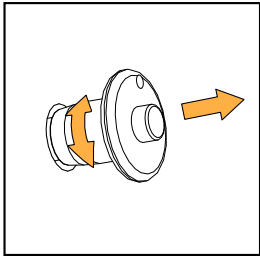

If the pin is inserted in two plates, the ball must pass through both plates and lock the pin in place.

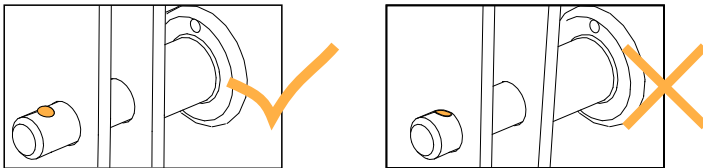

If the check fails, **immediately withdraw the product from use and contact L-Acoustics.**

Related tasks

[Rigging part inspection](#) (p.42)

Grill safety

Visually and mechanically inspect the grill safety.

Moving parts

Procedure

1. Make sure that the O-rings are not damaged.

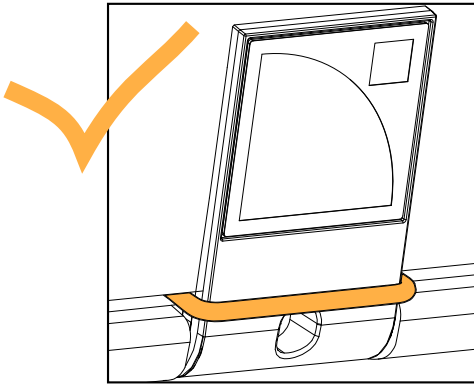

2. Make sure that the screw is tightened.

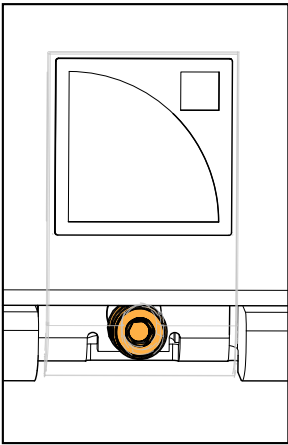

3. Pull on the O-rings:
 - Make sure they do not break.
 - Make sure they are not loose.

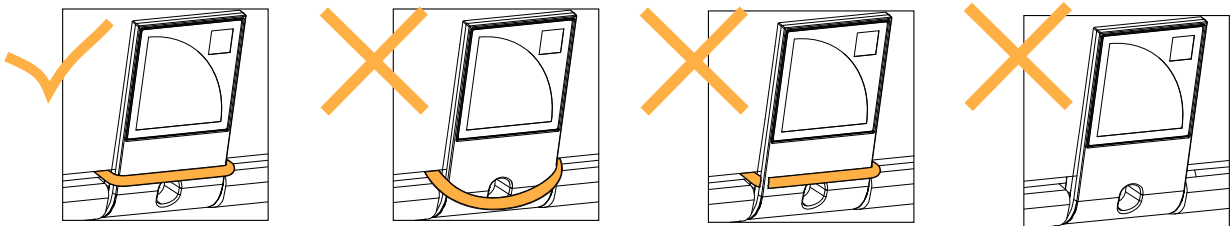

If the O-rings are damaged or missing, refer to the **D/R - Grill (p.109)** to replace them.

Rigging check

Procedure

1. Position a K1 on K1-CHARIOT.

i Enclosure can face either way.

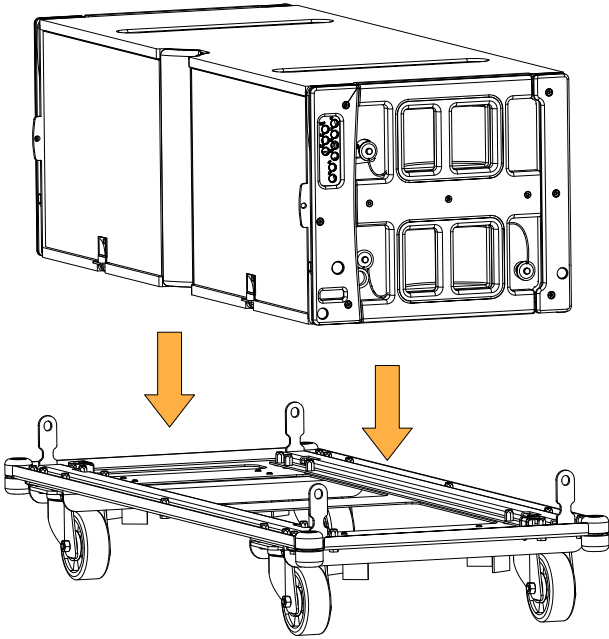

2. Position one K1 on the first one.

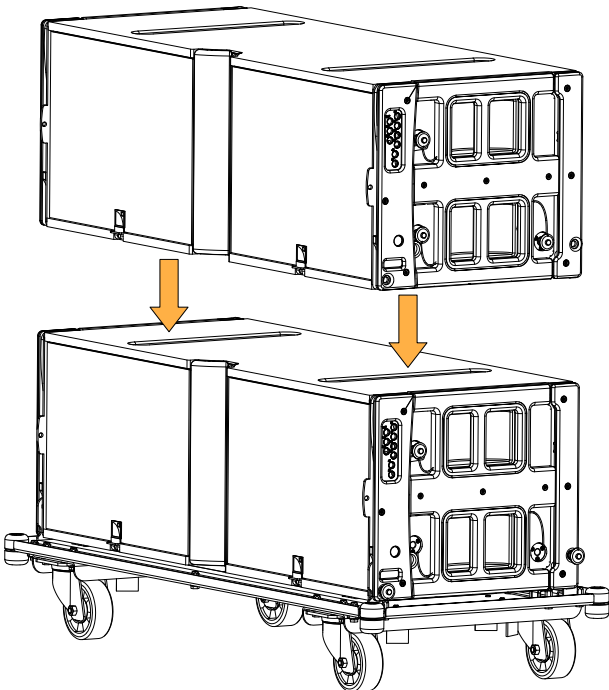

3. Secure the front rigging arms using the top enclosure pins.

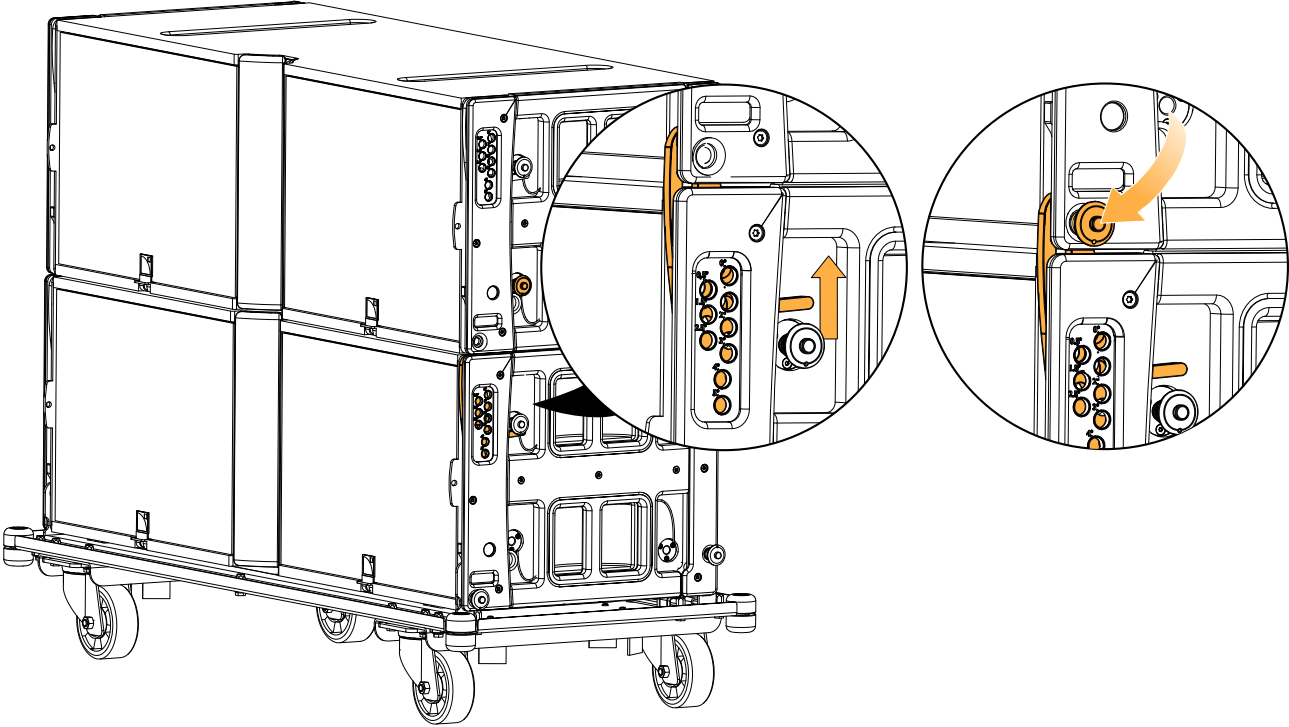

The front rigging arms can be deployed with some resistance, and slide correctly.

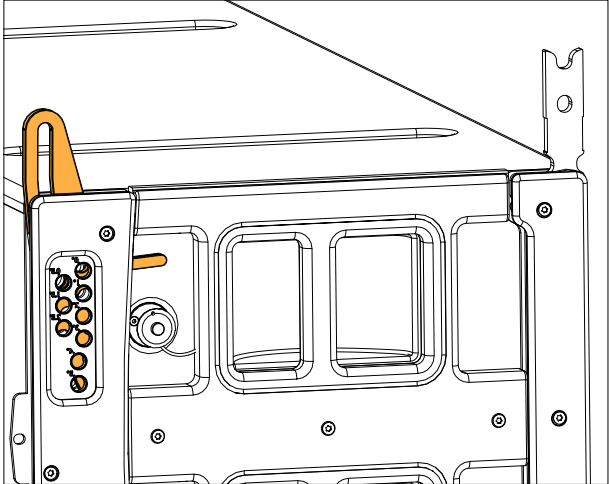

4. Secure the rear rigging arms using the top enclosure pins.

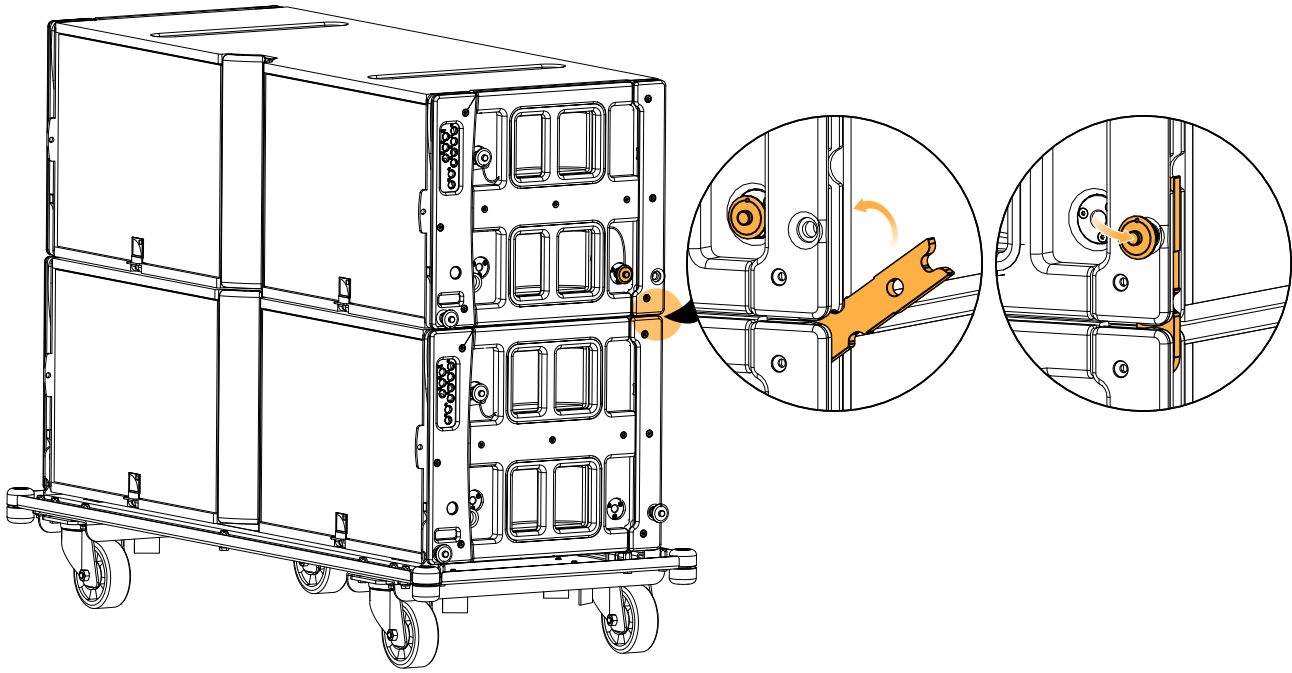

The rear rigging arms can be deployed with some resistance, and rotate correctly.

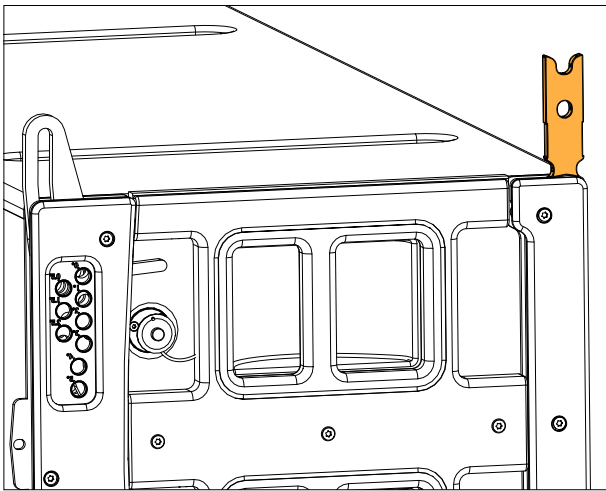

5. Make sure the automatic locking system is deactivated.
If the angle locking button is pressed, pull to disengage the latch.

i When the automatic locking system is deactivated, **a yellow sticker is visible** on the latch.

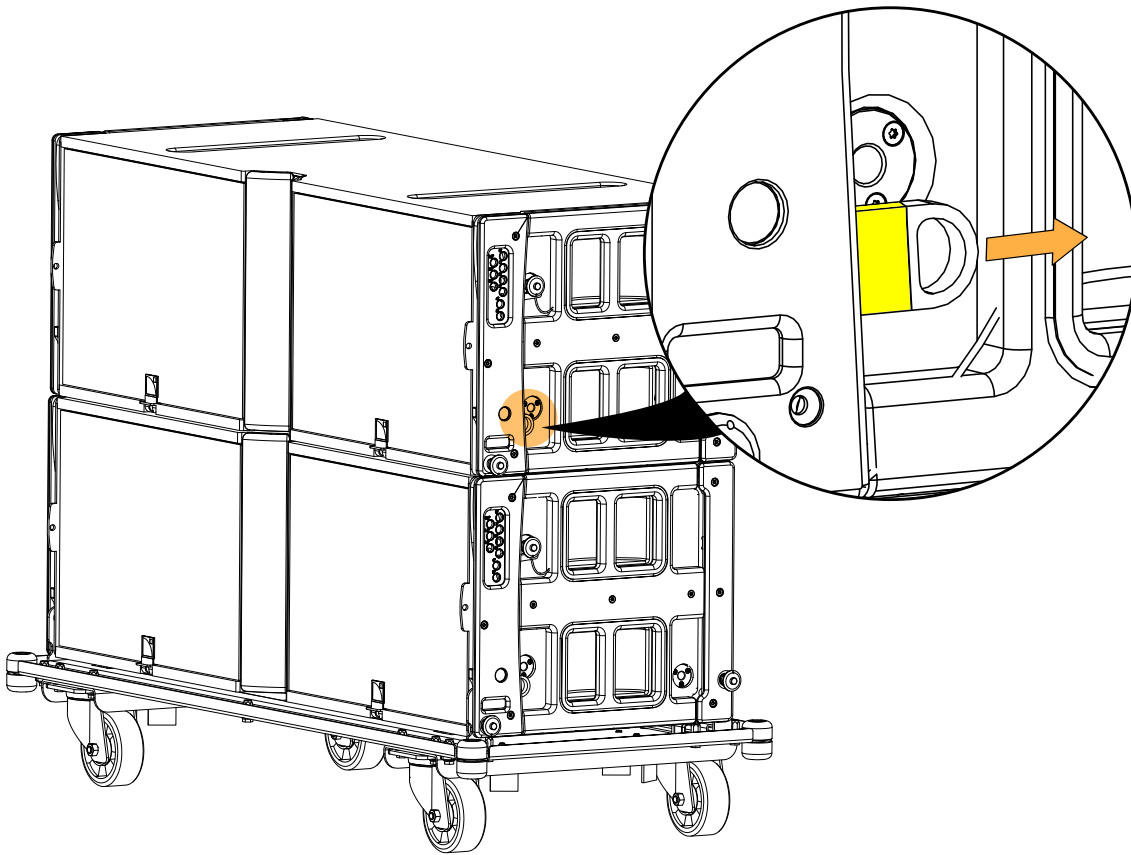

6. Secure the front rigging arms at one of the inter-enclosure holes.

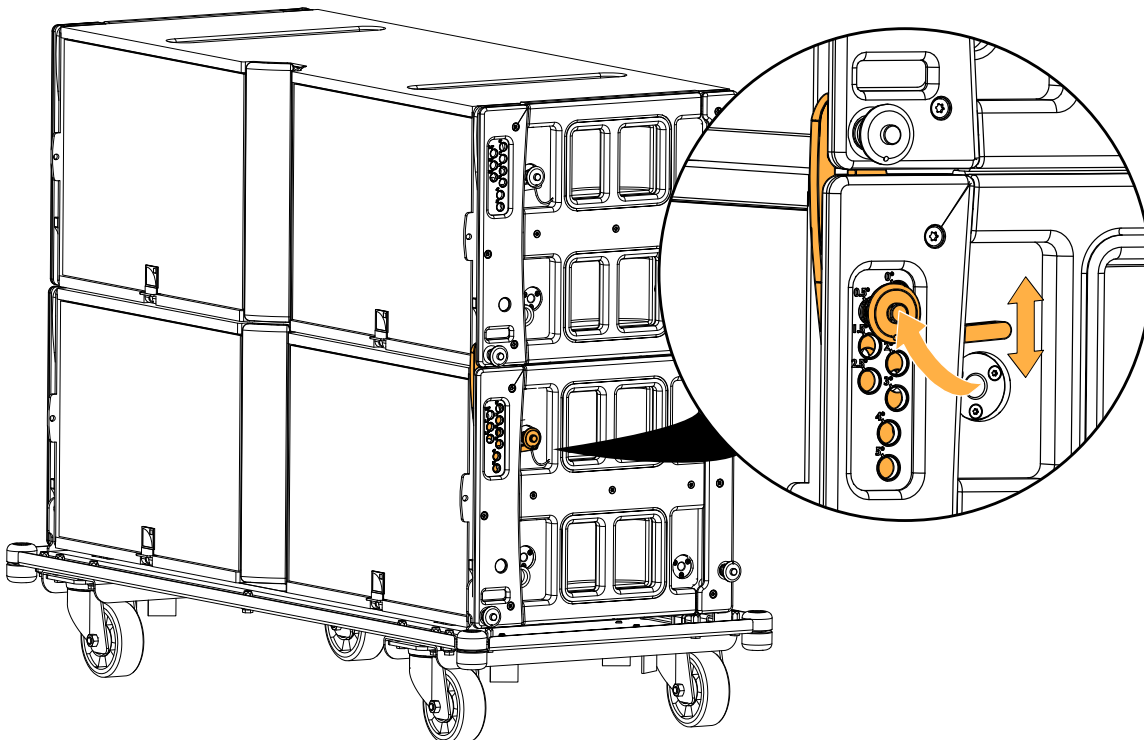

- 7.** Press the button to activate the automatic locking system.
- The latch slightly retracts when the button is pushed (yellow label visible).

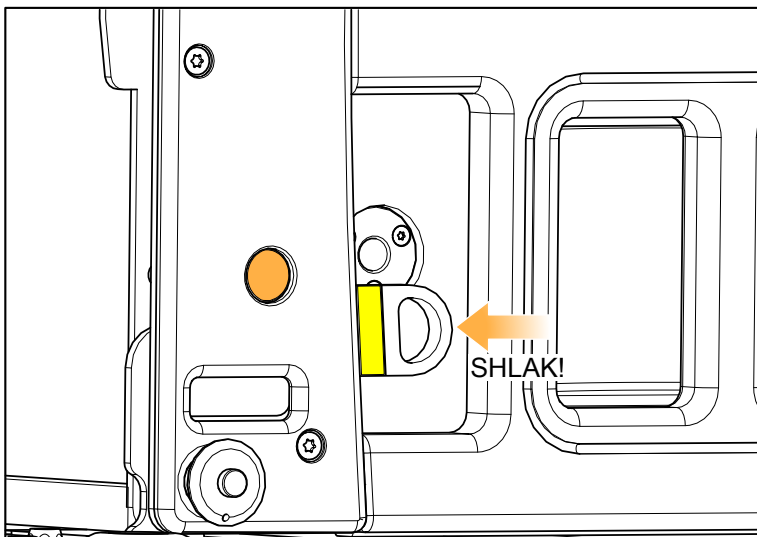

- 8.** Hold and lift the array to lock the inter-enclosure angles.
- The two enclosures remain attached.
 - The automatic locking system button locks and the latches engage (no yellow label visible).

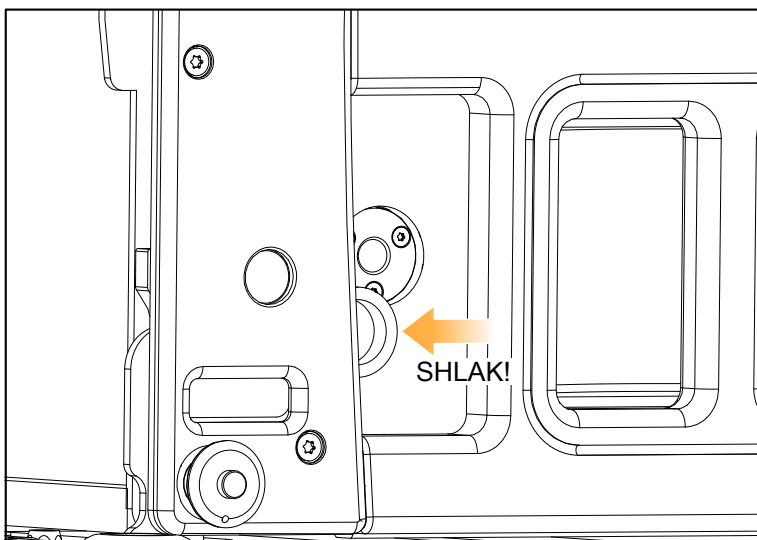

9. Disassemble the two enclosures.

**Risk of trapping fingers**

When disassembling the enclosures, hold the top one by the handles.

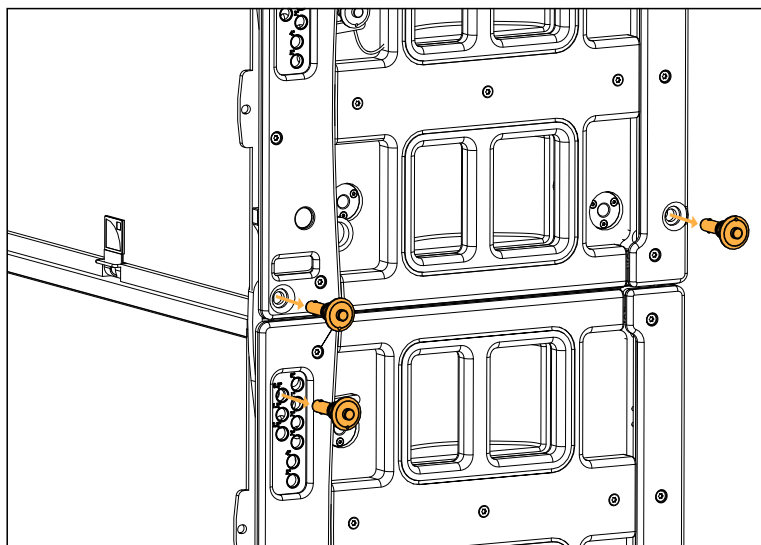

10. Repeat the procedure with the other enclosures.

Acoustical check

Enclosure check

 **This feature is available on:**
LA12X

ENCLOSURE CHECK measures impedance at the reference frequencies for the connected loudspeaker family. The measured impedance is compared to the expected range allowing for fast detection of loudspeakers presenting circuit continuity issues.

 The results can be used for preliminary diagnosis but cannot replace a comprehensive quality control.

Prerequisite

 **ENCLOSURE CHECK measurements can only be reliable if the following requirements are met:**

Environment and temperature:

- Ambient temperature must be comprised between 0 °C / 32 °F and 40 °C / 104 °F. Ideal temperature is 20 °C / 68 °F.
- Enclosures must be at room temperature. If warm from a recent high level use or recently moved from a cold environment, let the loudspeakers reach room temperature before starting.

Enclosures:

- Enclosures must be included in the embedded factory preset library.
- Enclosures must be in nominal operating conditions:
 - Remove covers or dollies obstructing the loudspeakers or the vents.
 - Check for obvious physical damage or air leak: visually inspect the grill, gasket, cabinet, and connector plate for loose, missing or damaged parts.

Connection:

- Use only 10 m / 30 ft 4 mm² / AWG 11 speaker cables.
- Do not connect enclosures in parallel.

Amplified controllers:

- Load a preset corresponding to the connected loudspeaker's family. Presets from the user memories may be used on condition they are made of presets supported in the embedded factory preset library.

Procedure

1. Power up the amplified controller.
2. Connect the loudspeaker enclosures to the amplified controller.
3. Load a preset from or built from the embedded library corresponding to the connected loudspeaker family.
4. On the amplified controller, use the encoder wheel to select **MONITORING & INFO**. Press the OK key or the encoder wheel to validate.
5. Use the encoder wheel to select **ENCLOSURE CHECK**.



Beware of sound levels.

Although the sound pressure levels generated for the ENCLOSURE CHECK are moderate, do not stay within close proximity of the loudspeakers and consider wearing ear protection.

6. Press the OK key or the encoder wheel to launch the ENCLOSURE CHECK.

The amplified controller generates short sinusoidal signals simultaneously for each connected output.

The amplified controller displays the results for each output.

7. Depending on the displayed results, follow the instructions in the table.

result	interpretation	instructions
OK	measured impedance is within expected range	enclosure is in working order electrically
?	unsupported preset family	only supported enclosures should be tested
NC	Not Connected	if cables are connected: a. inspect the cables and connections b. go to step 8 (p.59)
NOK	measured impedance is not within expected range	a. check that all the prerequisites are met, in particular that the loaded preset corresponds to the connected speaker's family b. inspect the cables and connections c. go to step 8 (p.59)
UNDEF	measured impedance is undefined	

8. Under NC, NOK and UNDEF results, press and hold the corresponding OUT key.

The amplified controller displays:

- the tested frequencies,
- information on the measured impedance:
 - OPEN for open circuit (found in NC results),
 - SHORT for short circuit (found in NOK results), or
 - a percentage of variation from the expected range (found in NOK and UNDEF results)
- the number of operational transducers out of the total



Low variations from the expected range are acceptable: displayed percentage can be different from 0 and all transducers considered operational.

Listening test

enclosure	preset	usable bandwidth
K1	[K1]	35 Hz - 20 kHz
K2	[K2 70]	35 Hz - 20 kHz
Kara II	[KARA II 70]	55 Hz - 20 kHz
K1-SB	[K1SB_60]	30 Hz - 80 Hz

Procedure

1. Load the preset on an LA12X amplified controller.
2. Connect a sine wave generator to the amplified controller.



Risk of hearing damage

Set a low sound level to start and use ear protection to adjust before testing.

3. Scan the bandwidth focusing on the usable range.
The sound should remain pure and free of unwanted noise.

Troubleshooting for LF/MF speakers

One or more LF/MF speaker produces distorted, buzzing, rubbing, clicking, muffled or weak sound.

Possible causes

- The screws are not tightened with the appropriate torque.
- There is an air leak in the gasket.
- There is dust on the cone.
- The cone is damaged.
- The surround is torn or delaminated.
- The voice coil or the spider is damaged.

Procedure

1. Perform the speaker disassembly procedure.
2. Visually inspect the cables and the connectors.
3. Visually inspect the speaker cone, the voice coil and the spider.

If any damage is visible, replace the speaker.

4. Carefully clean the speaker with a dry cloth.
5. Perform the reassembly procedure.
Replace the speaker gasket and the screws.
Apply the recommended torque.
6. Repeat the listening test.

If the problem persists, replace the speaker.

Troubleshooting for HF drivers

One or more HF driver produces high-frequency harmonic distortions, strange vibrations or weak sound.

Possible causes

- There are foreign particles on the air gap.
- The diaphragm is not centered correctly.
- The screws used for reassembly are too loose.
- The diaphragm is damaged.

Procedure

1. Perform the diaphragm disassembly procedure.
2. Visually inspect the diaphragm and the voice coil.
If any damage is visible, replace the diaphragm.
3. Clean the air gap thoroughly.
Use double-face adhesive tape to remove any particles.
4. Perform the diaphragm reassembly procedure.
Apply the recommended torque.
5. Repeat the listening test.
If the problem persists, replace the driver.

Rigging procedures

Preparing K1-BUMP

Min number of operators	2
Rigging accessories	K1-BUMP 4 Ø 22 mm shackles WLL 3.25 t K1-DELTA (optional) K1-BPCHAIN (optional)

- !** **All along the procedure:**
Systematically ensure that each ball-locking pin is fully inserted by pulling on it.
- !** To avoid any physical handling, K1-BUMP must be transported and prepared in K-BUMPFLIGHT.
- !** An identification sticker is present at the front of K1-BUMP to identify the front and the rear sides.

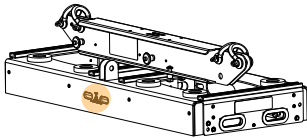

Procedure

1. Place K-BUMPFLIGHT at the rigging location. Remove the lid and the first compartment.

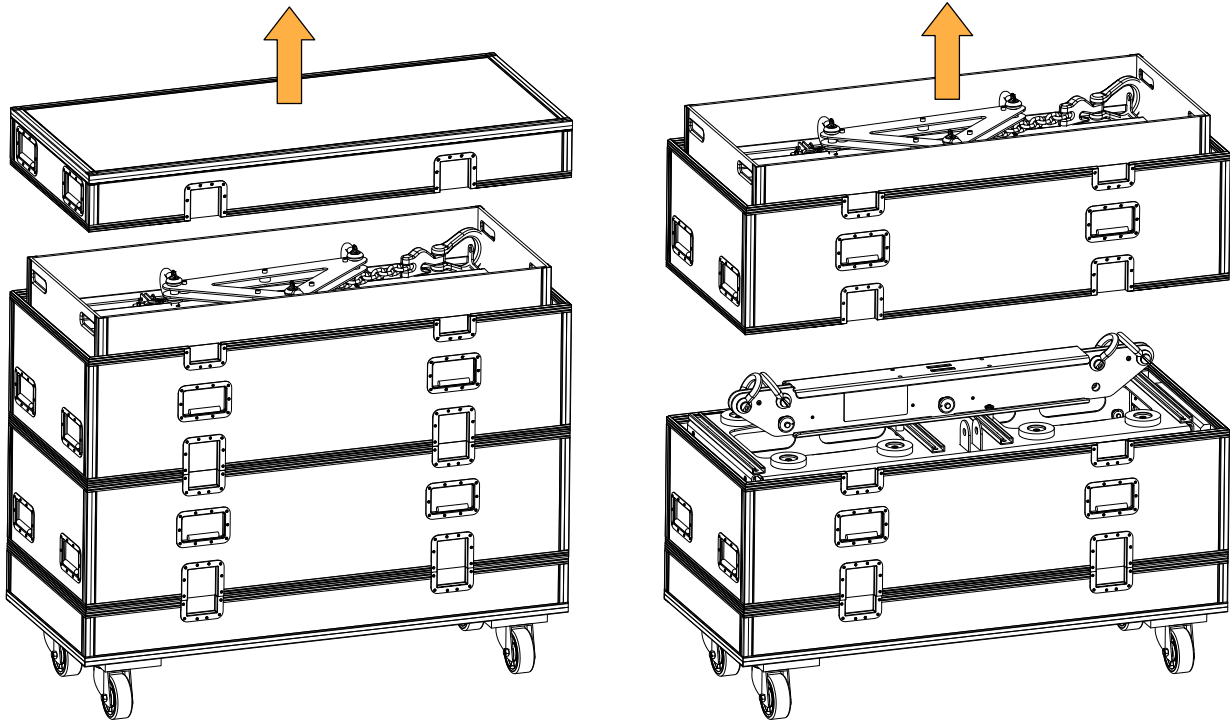

- 2.** On each side of the K1-BUMP rigging bar, remove the storage ball-locking pin. Secure the storage ball-locking pin in the rigging bar.

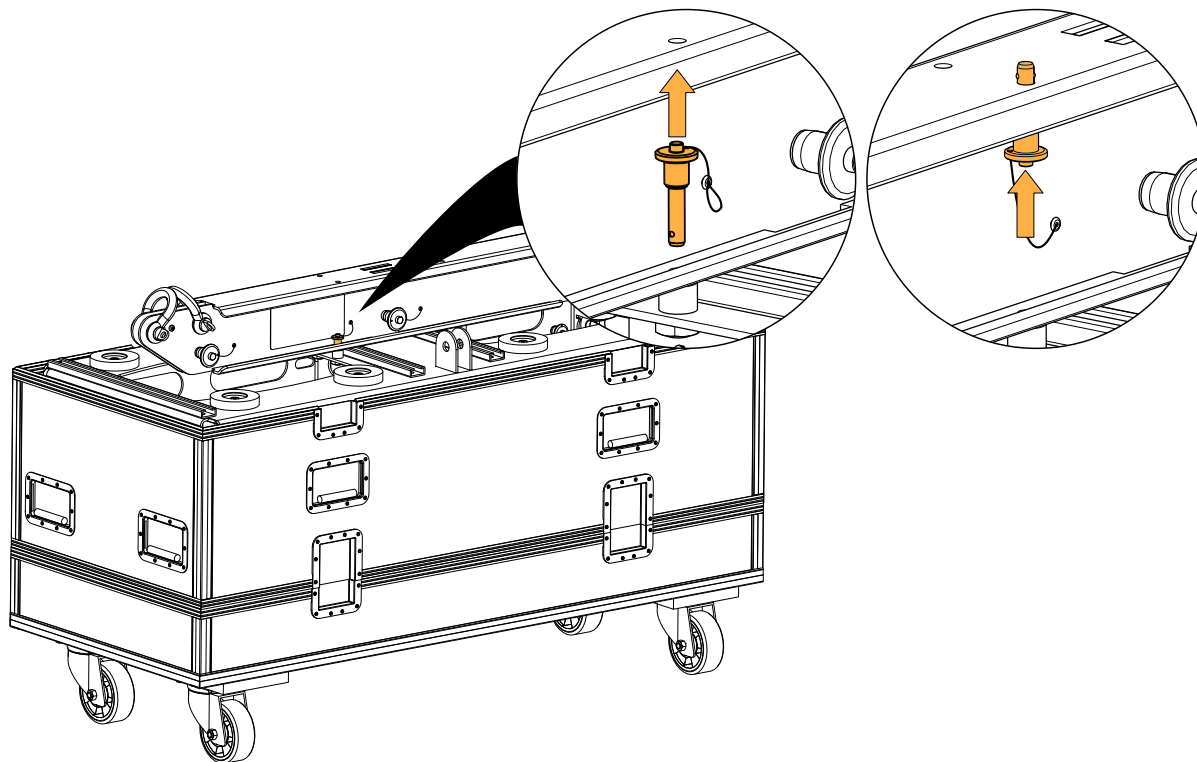

- 3.** Remove the two rigging ball-locking pins.

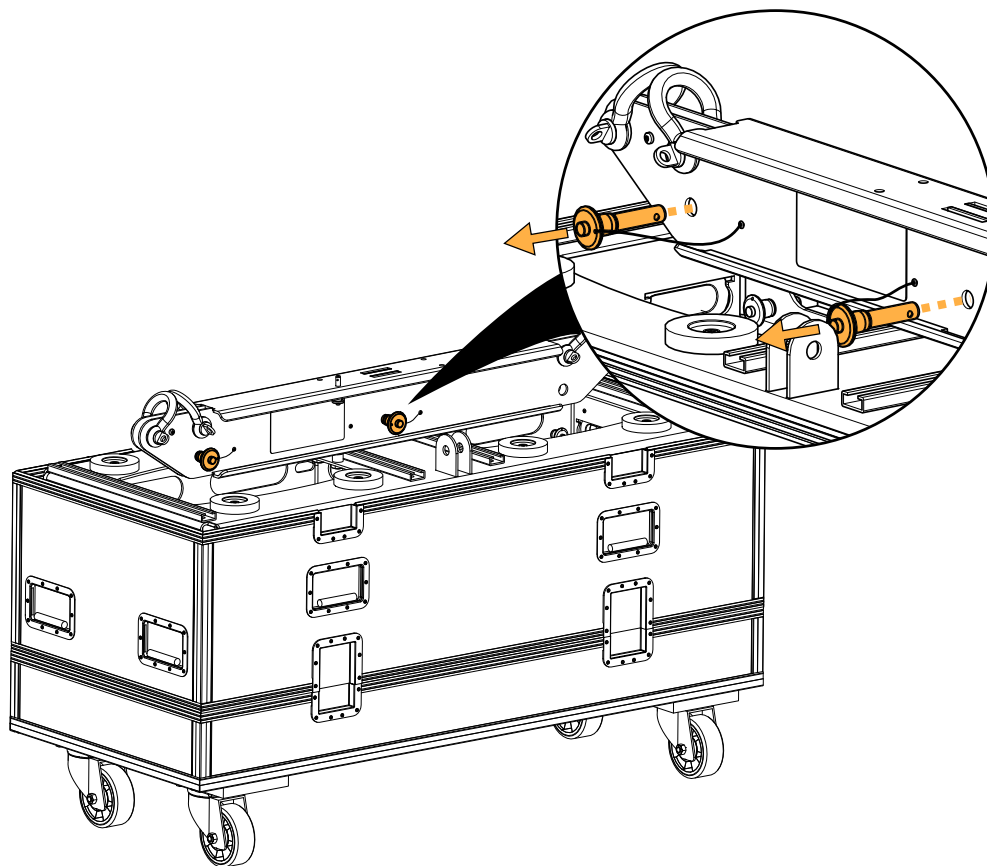

- 4.** Put the K1-BUMP rigging bar in rigging position:
a) Lift the K1-BUMP rigging bar using the motor.

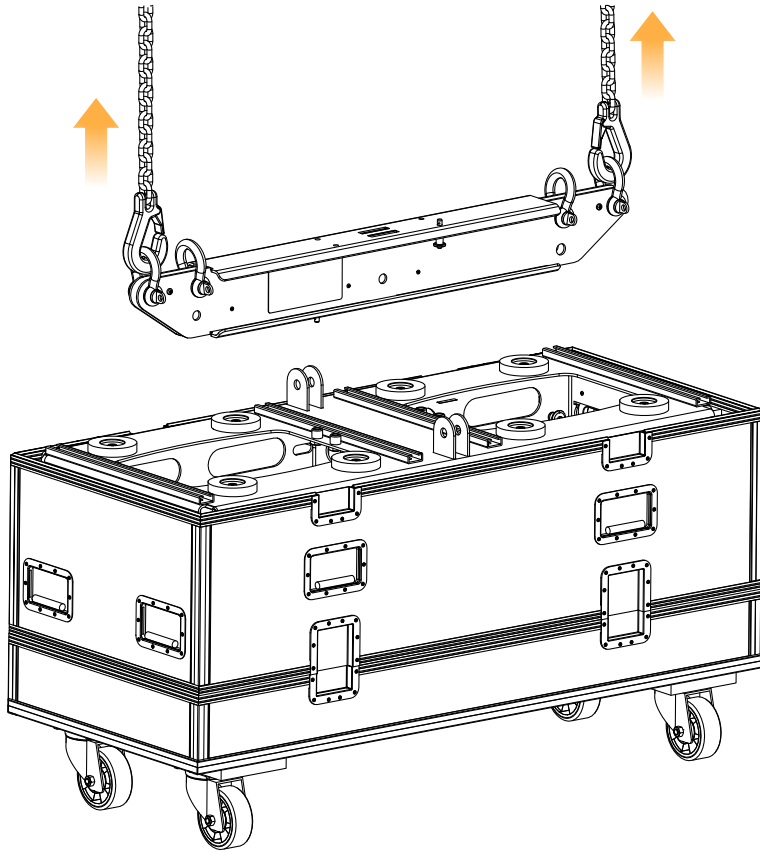

- b) Rotate K-BUMPFLIGHT and align K1-BUMP rigging frame holes with the rigging bar holes.

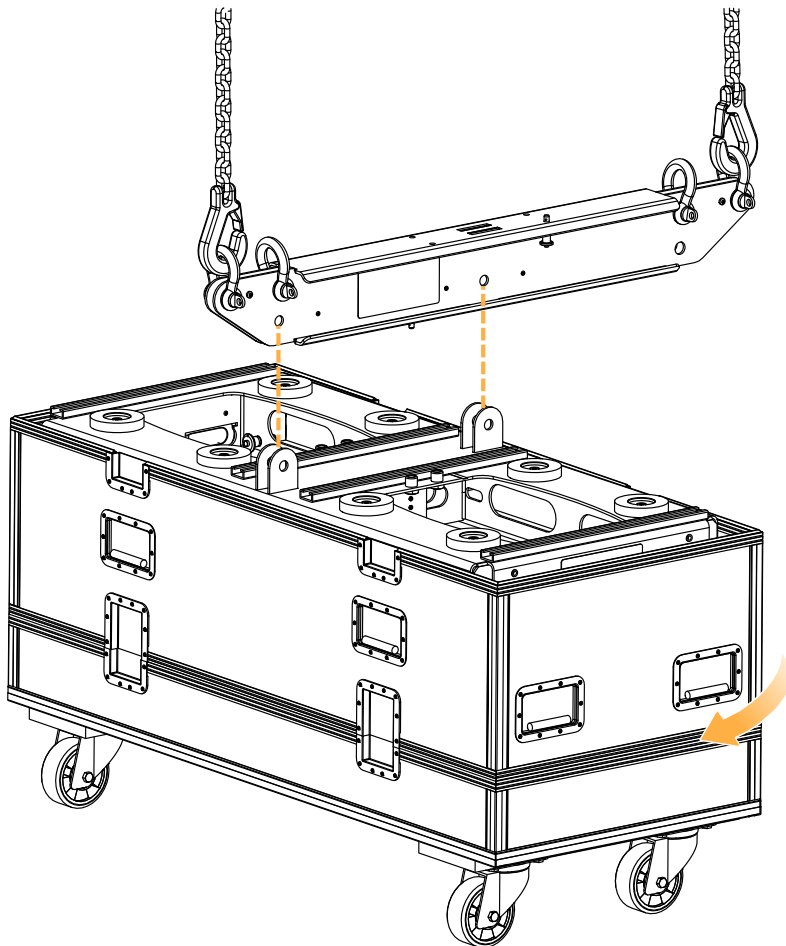

c) Lower and position the K1-BUMP rigging bar on K1-BUMP rigging frame.

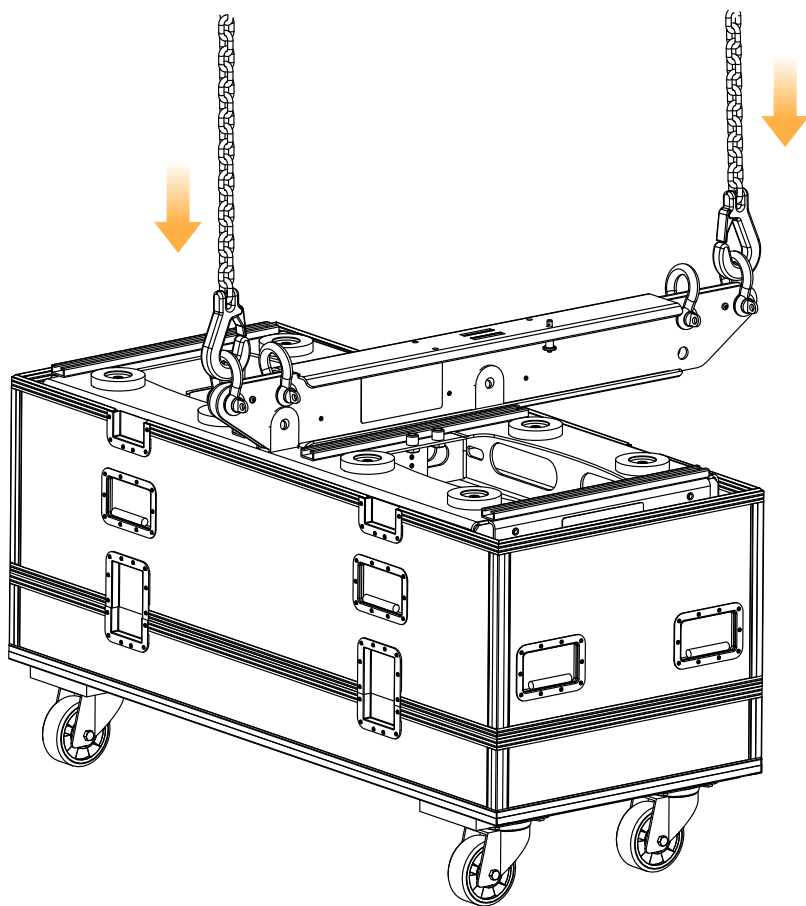

5. Secure the K1-BUMP rigging bar using the two rigging ball-locking pins.

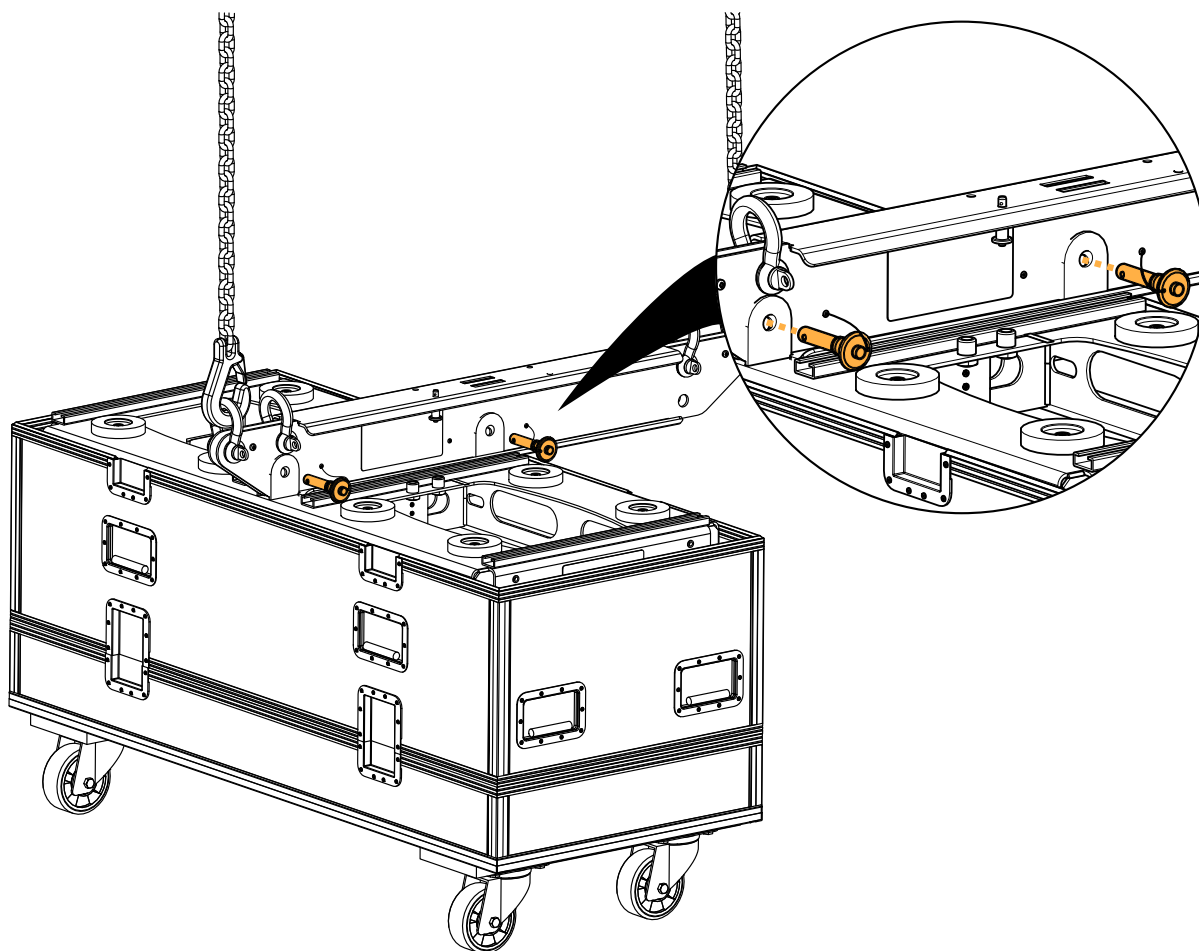

6. Optional:

- Secure K1-BPCHAIN to the front external shackle.
- Secure K1-DELTA to the rear external shackle.

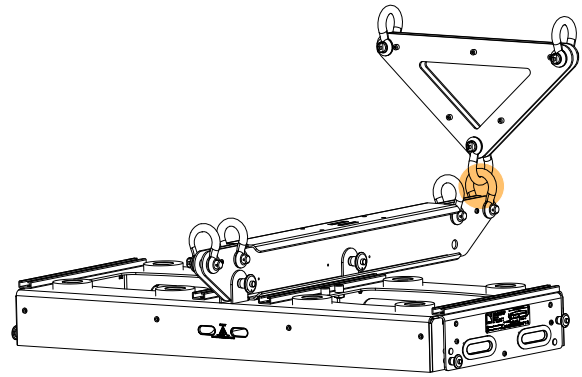
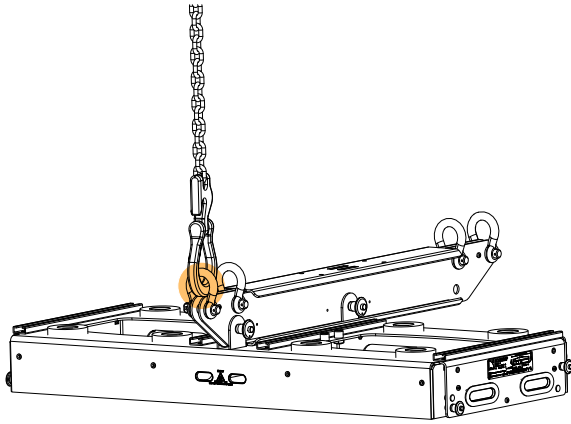

7. Lift K1-BUMP using the motor.

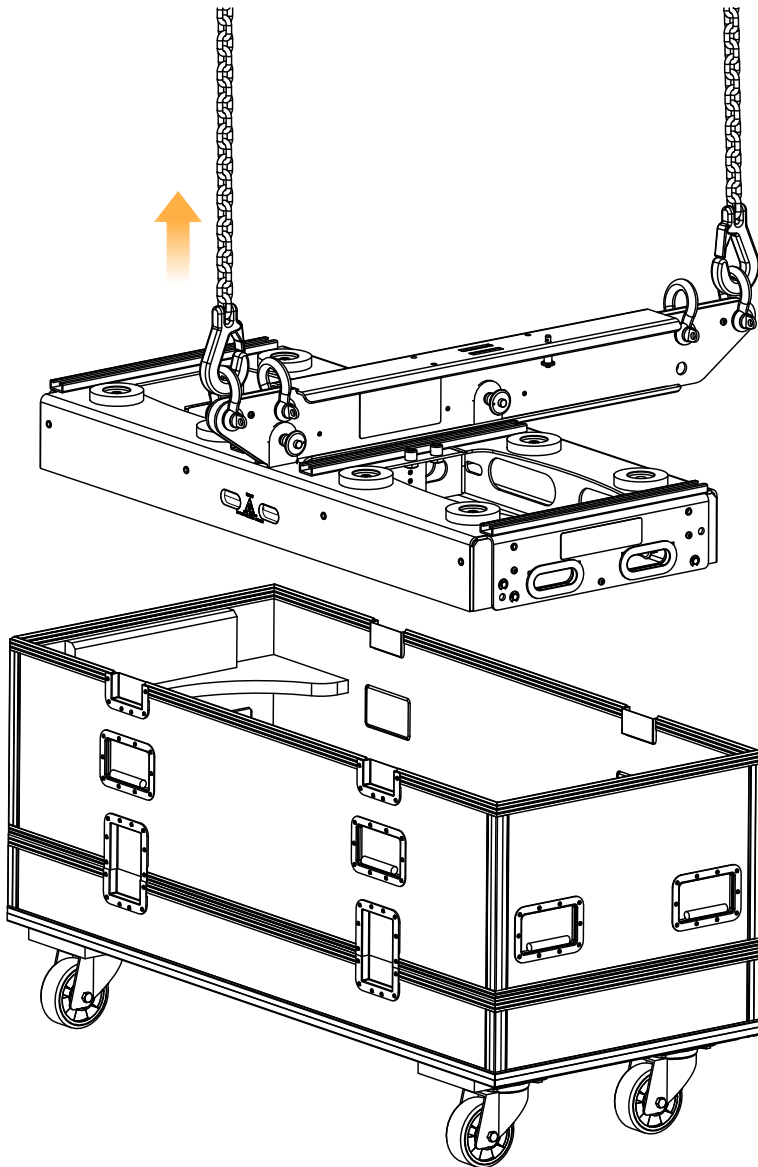

Securing LA-RAK II AVB on K1-BUMP

Min number of operators	2
Rigging accessories	K1-BUMP
	4 Ø 22 mm shackles WLL 3.25 t
	Rack stabilizer

! A maximum of four LA-RAK II AVB can be rigged on top of the K1-BUMP.

Prerequisite

Prepare K1-BUMP for rigging and place it on the ground. Refer to [Preparing K1-BUMP](#) (p.62).

Procedure

1. Remove the coupling bars from LA-RAK II AVB.

Turn the spring-loaded safety mechanisms to release the bars and slide them out.

! Make sure the spring-loaded safety is intact.

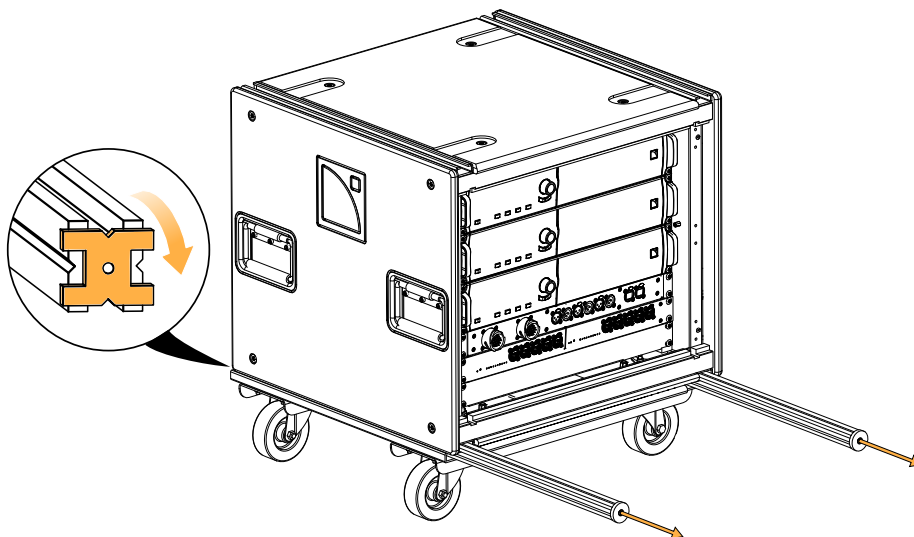

2. Position LA-RAK II AVB on K1-BUMP.

! LA-RAK II AVB must be installed with the front panel oriented towards the K1-BUMP laser slits.

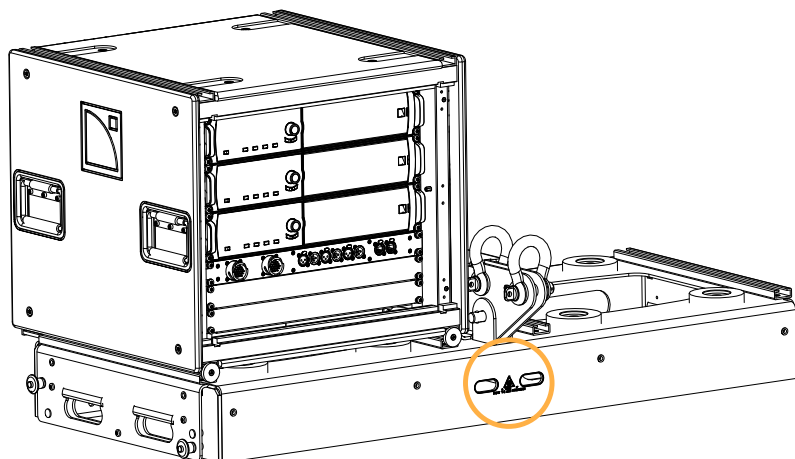

3. Secure LA-RAK II AVB with the coupling bars:

! Always insert the coupling bars so that the plastic spring-loaded safety points toward the ground (depending on the site angle):

- From the front for a positive site angle.
- From the back for a negative site angle.

- a) Insert the spring-loaded safety in the LA-RAK II AVB rails.
- b) Give a quarter turn and slide the bar until the safety locks into place.

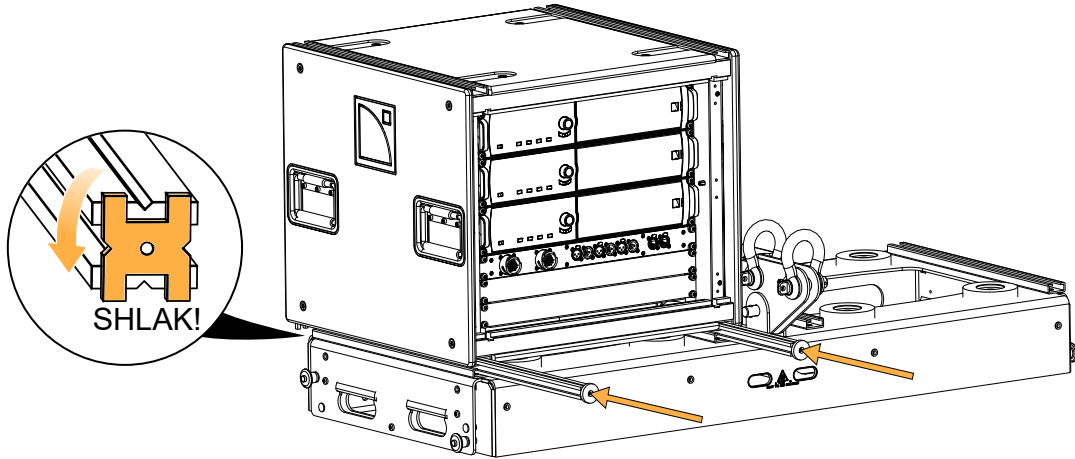

4. Repeat steps from 1 (p.67) to 3 (p.68) to secure up to four LA-RAK II AVB on K1-BUMP.

! **Risk of falling**
 If two racks are used, each one must be placed directly onto K1-BUMP.
 If four racks are used, they must be arranged in two dual-rack columns.

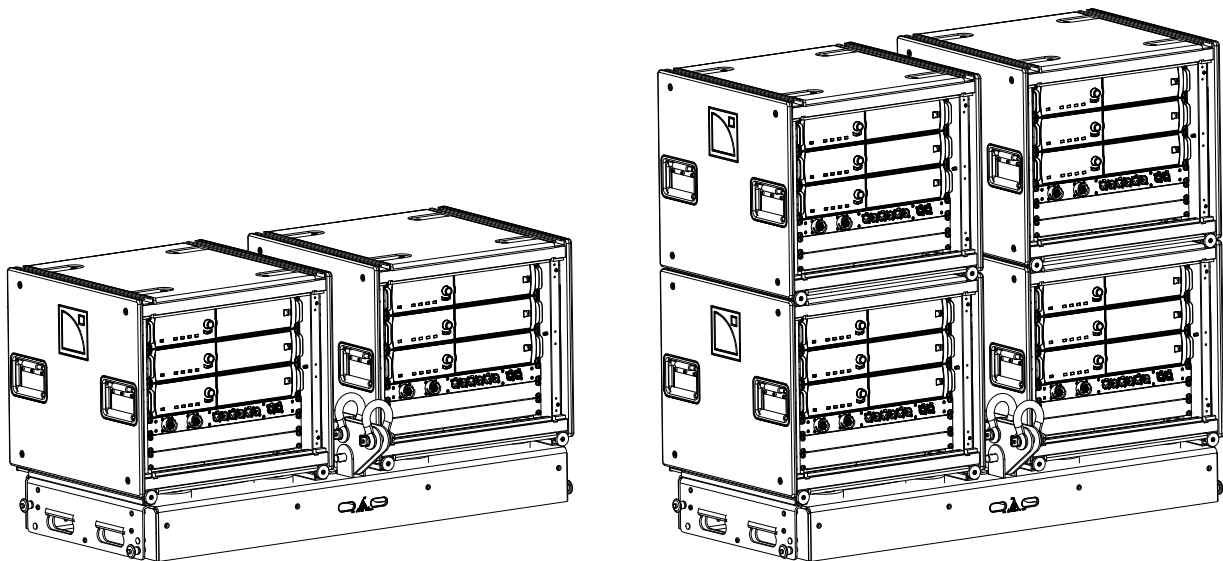

5. Slide the rack stabilizer along the top LA-RAK II AVB rails until it locks. If necessary, unscrew the rack stabilizer safety screw.

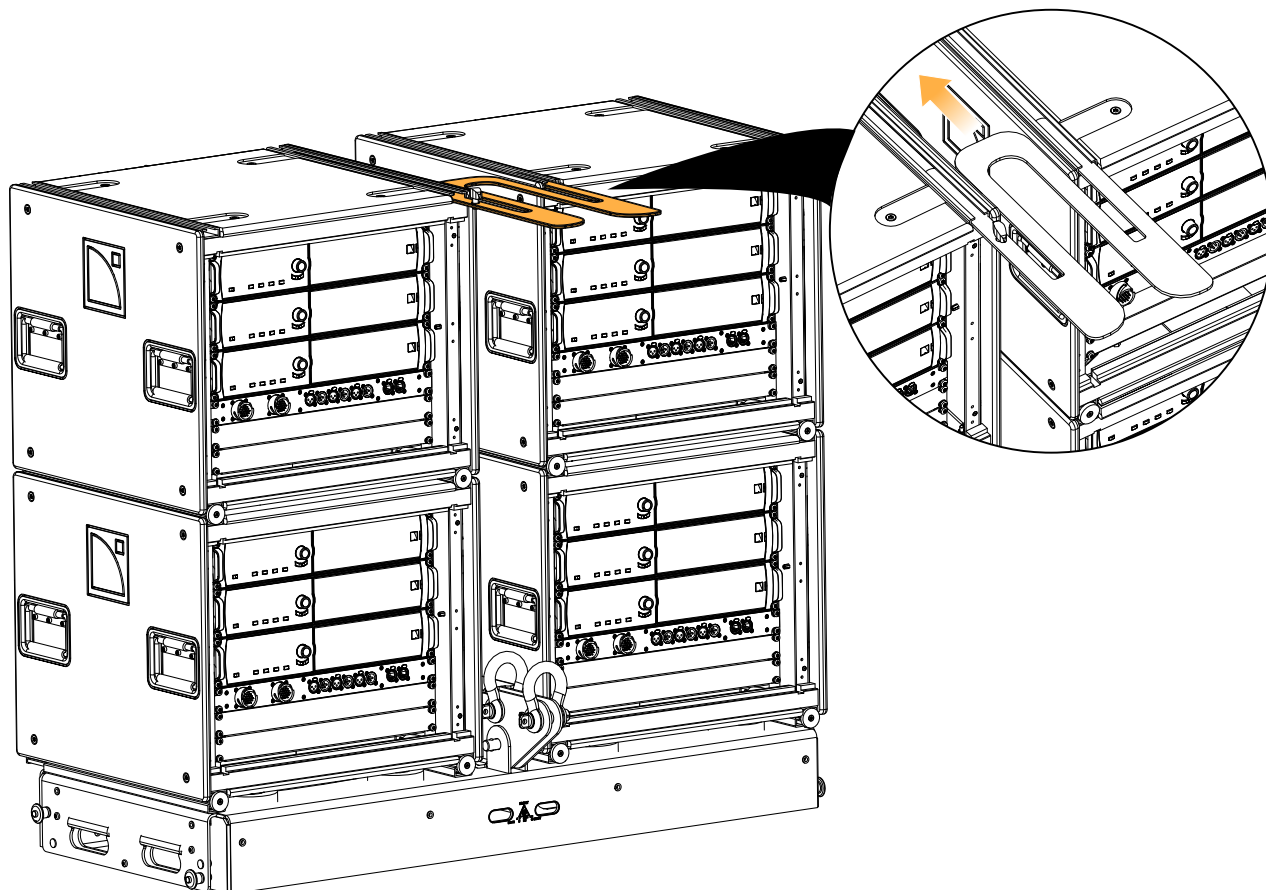

6. Screw in the rack stabilizer safety screw.

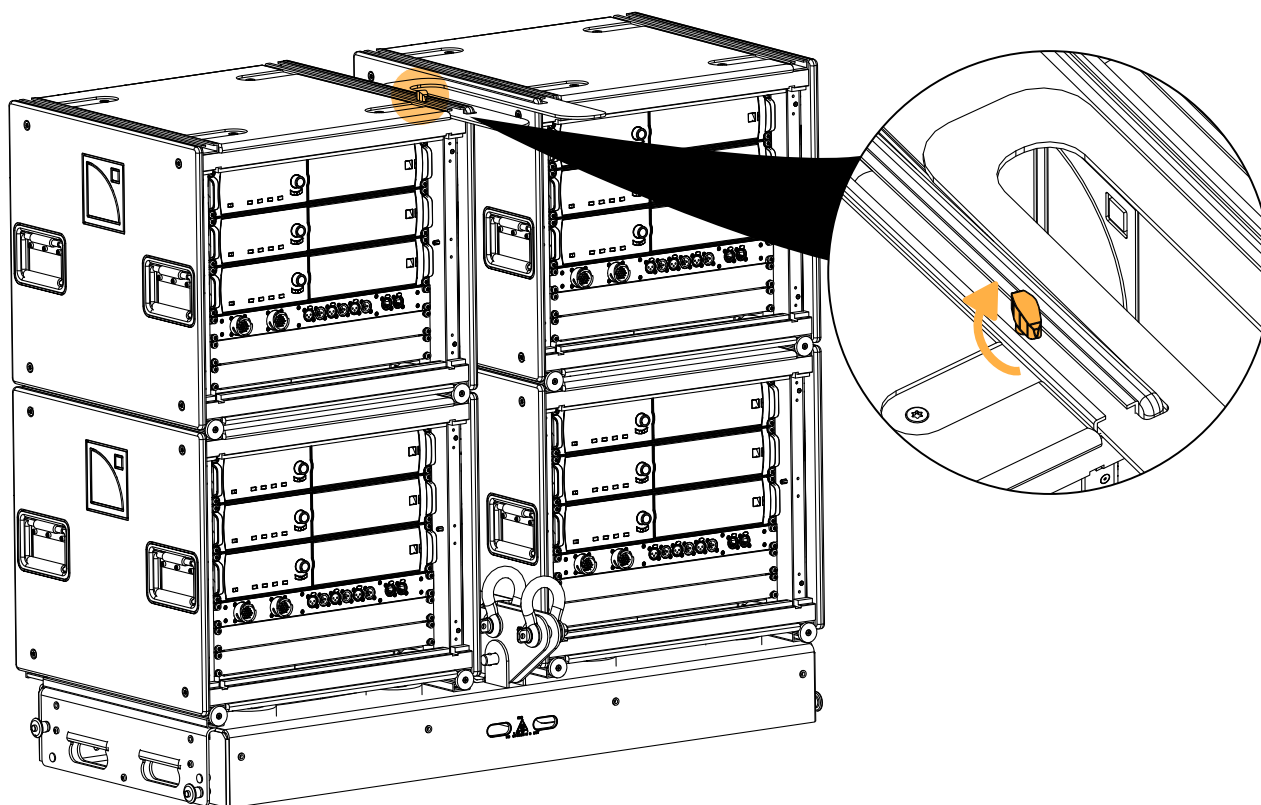

7. Secure the motor hooks to the external shackles of the K1-BUMP rigging bar.
If two or four LA-RAK II AVB are installed, place the front motor chain into the groove of the rack stabilizer.

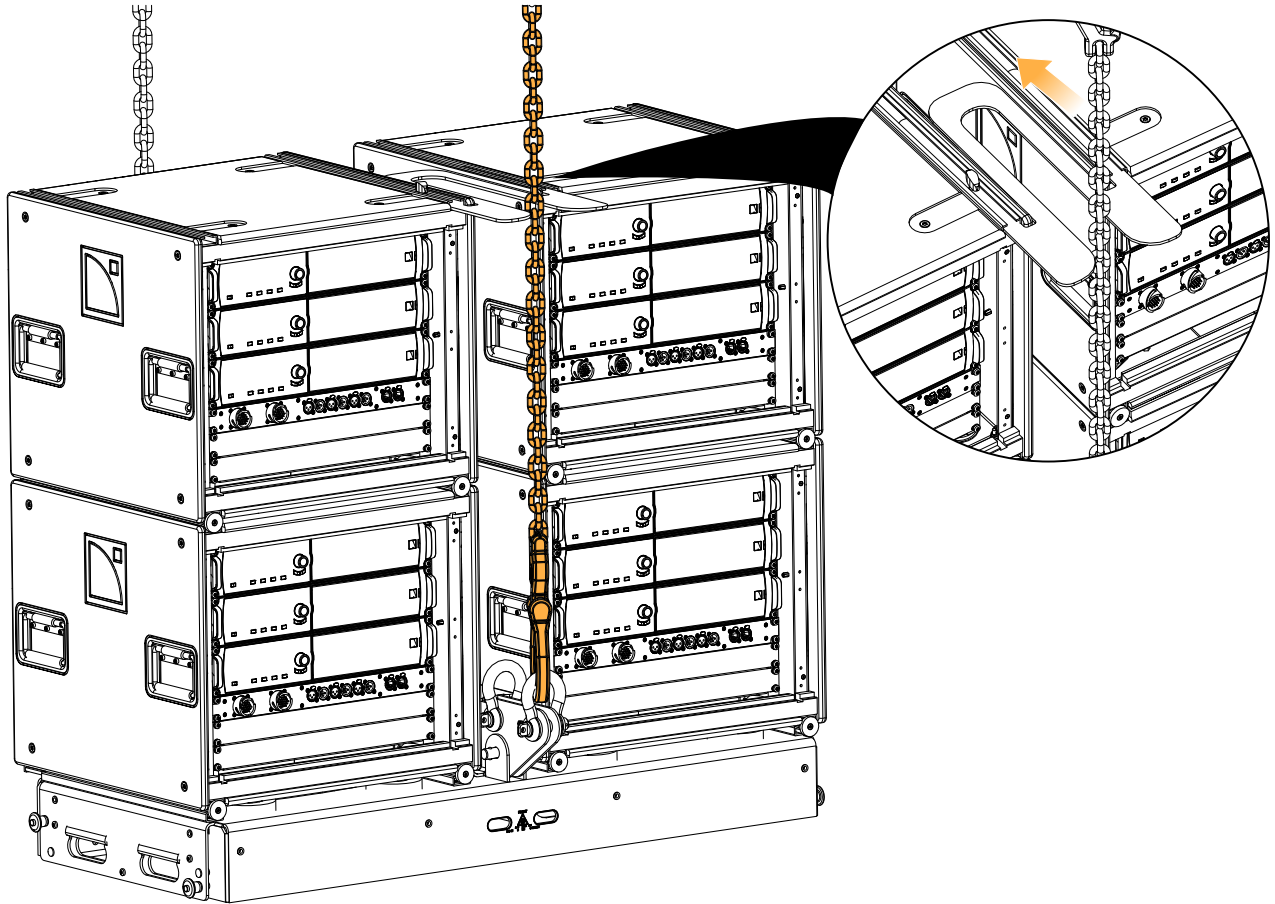

If one or three LA-RAK II AVB are installed, place the front motor chain on the external side of the rack stabilizer to prevent K1-BUMP from tilting during enclosure rigging.

i The front motor chain must be slid back into the groove of the rack stabilizer after enclosures rigging.

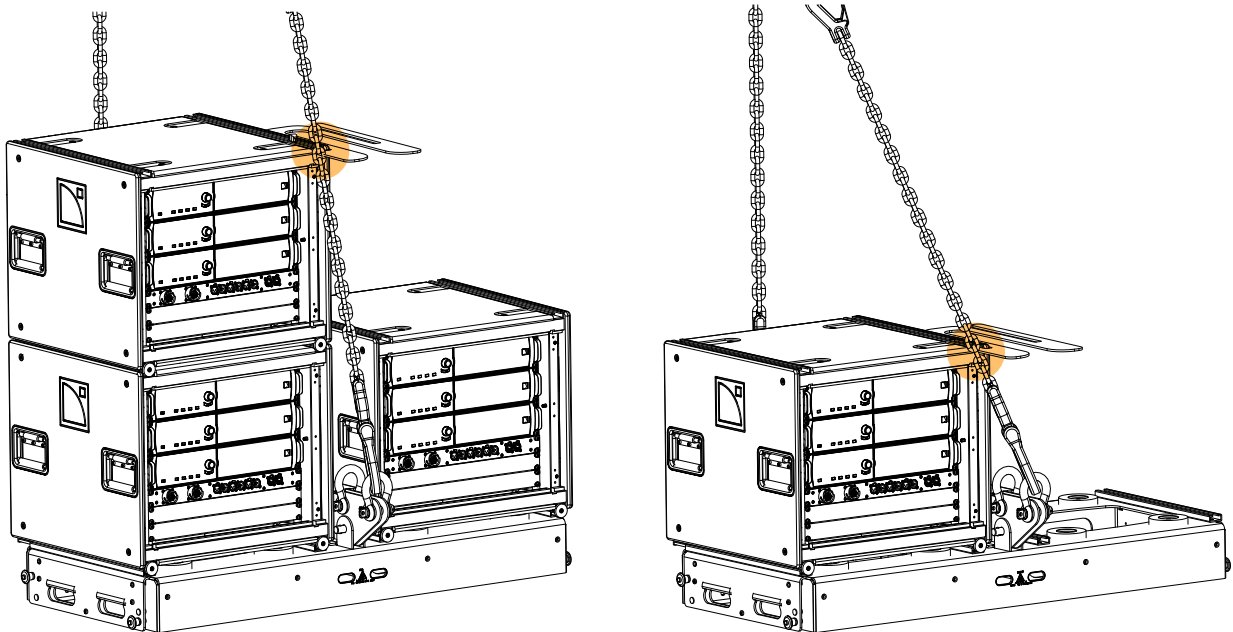

Preparing a block of four K1/K1-SB

Min number of operators	2
Rigging accessories	K1-CHARIOT

! **All along the procedure:**
Systematically ensure that each ball-locking pin is fully inserted by pulling on it.

i Follow the same procedure for K1-SB enclosures.

Procedure

1. Position a first K1 on K1-CHARIOT.

i Enclosure can face either way.

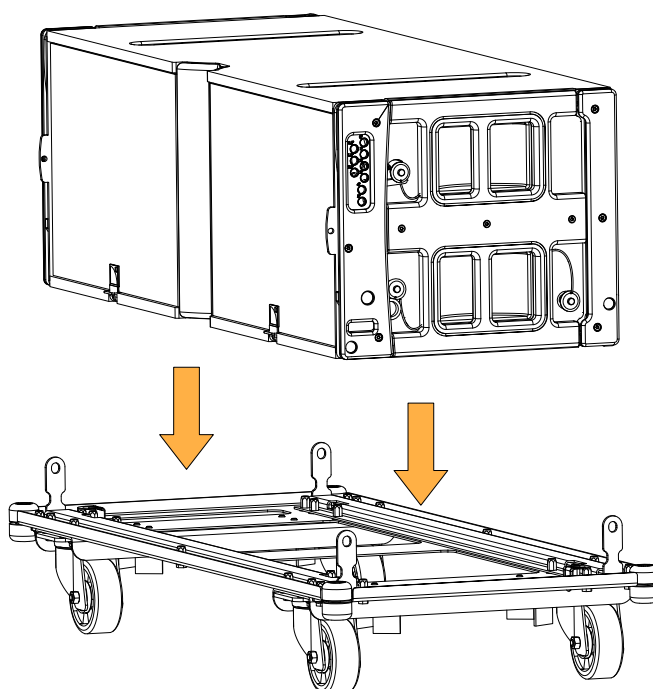

2. Secure the enclosure using the ball-locking pins.

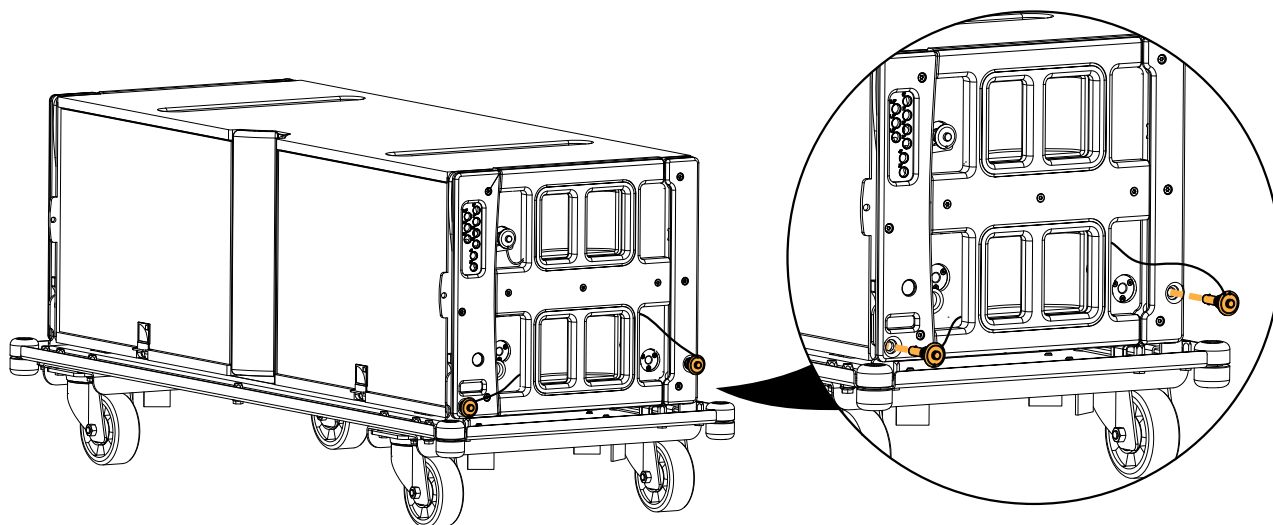

- 3.** Position another K1 on the first one.

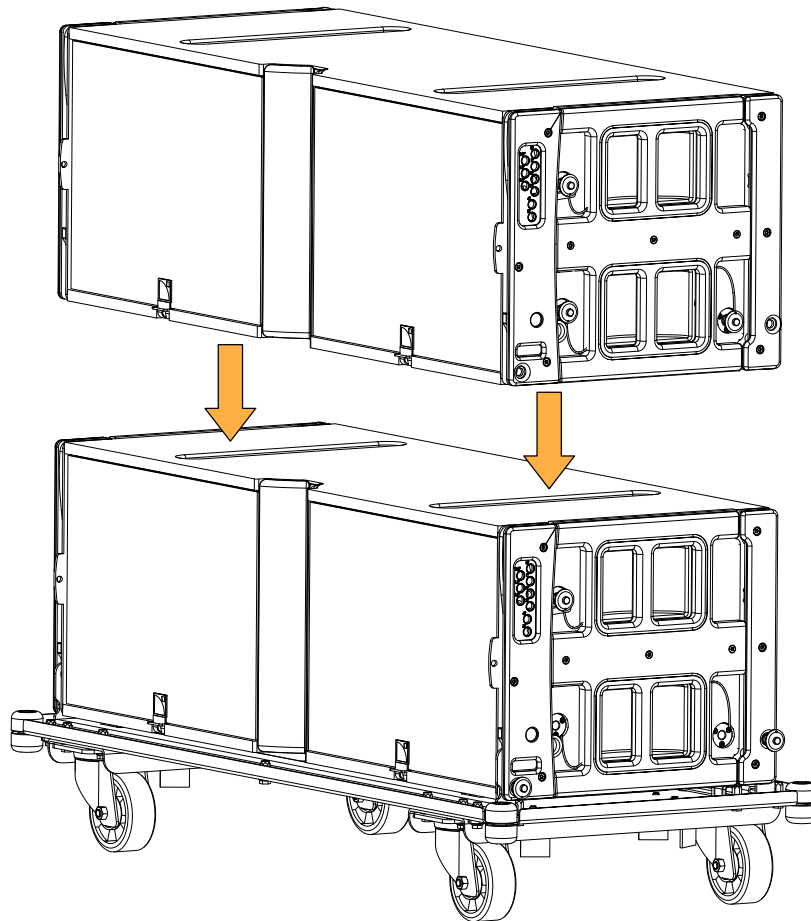

- 4.** On each side of the bottom enclosure, secure the front rigging arm to the top enclosure:
a) Slide the front rigging arm.
b) Secure the front rigging arm using the ball-locking pin of the top enclosure.

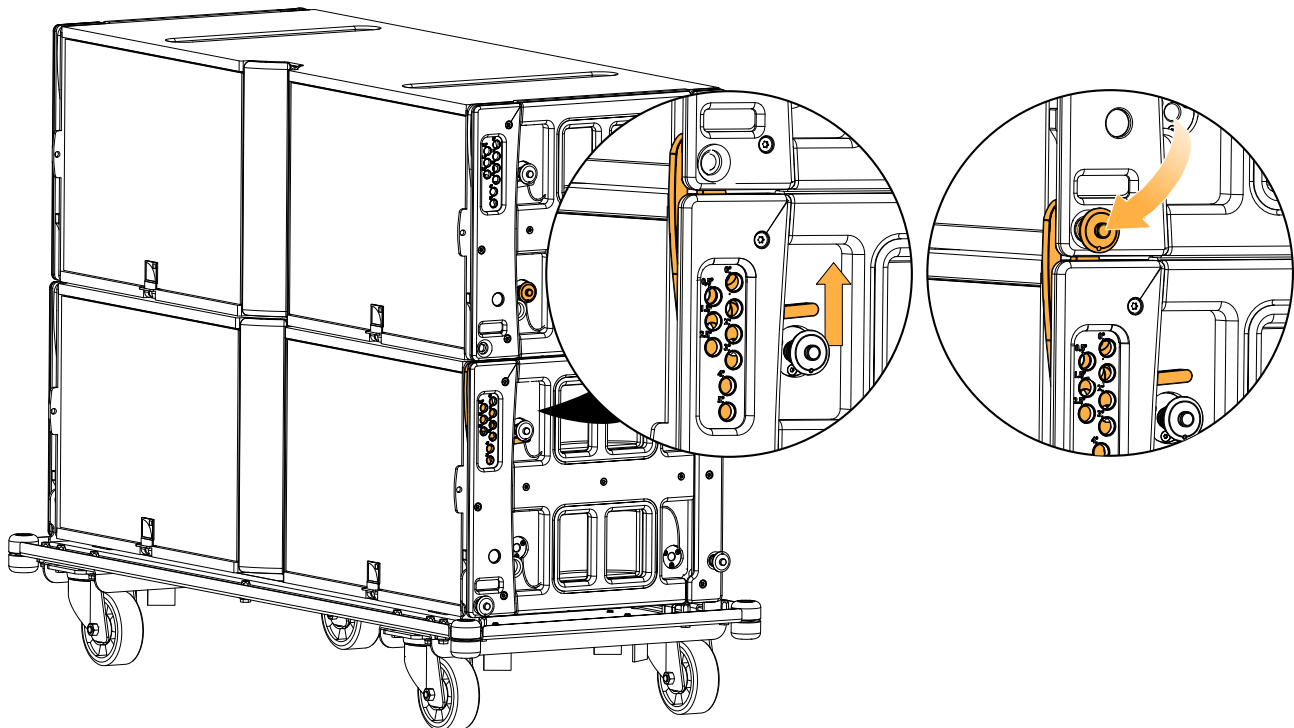

- 5.** On each side of the bottom enclosure, secure the rear rigging arm to the top enclosure:
- Rotate the rear rigging arm.
 - Secure the rear rigging arm using the ball-locking pin of the top enclosure.

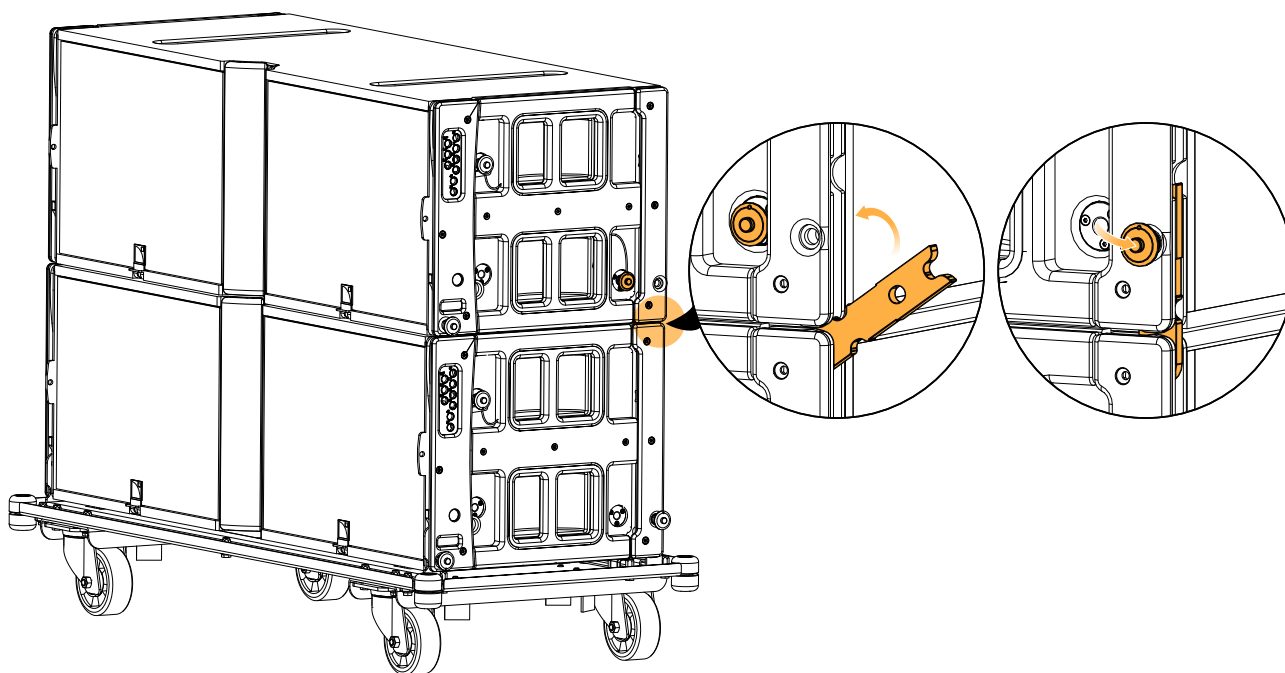

- 6.** Repeat steps 3 (p.72) to 5 (p.73) until the block of four K1 is complete.
- 7.** On each side of the top enclosure, set the angle at 0° using the top ball-locking pin.

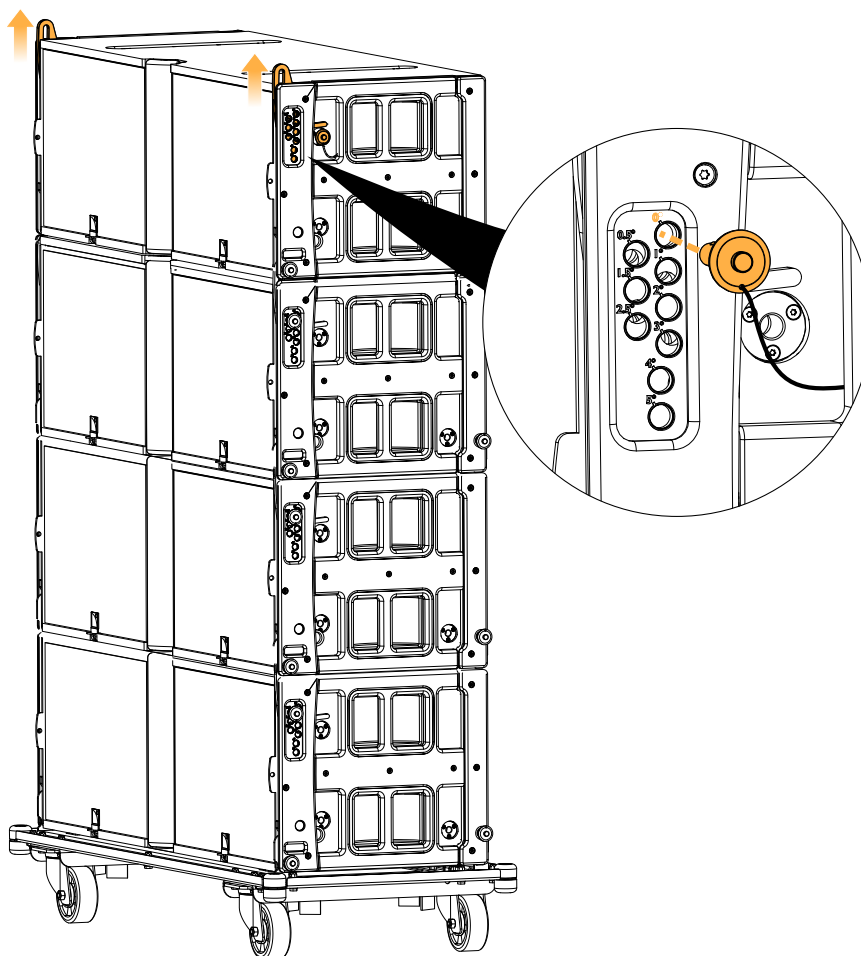

Presetting the inter-enclosure angles of K1/K1-SB

! **All along the procedure:**
Systematically ensure that each ball-locking pin is fully inserted by pulling on it.

i Follow the same procedure for K1-SB enclosures.

Procedure

1. Make sure the automatic locking system is deactivated.
If the latch is engaged, pull it to deactivate the automatic locking system.

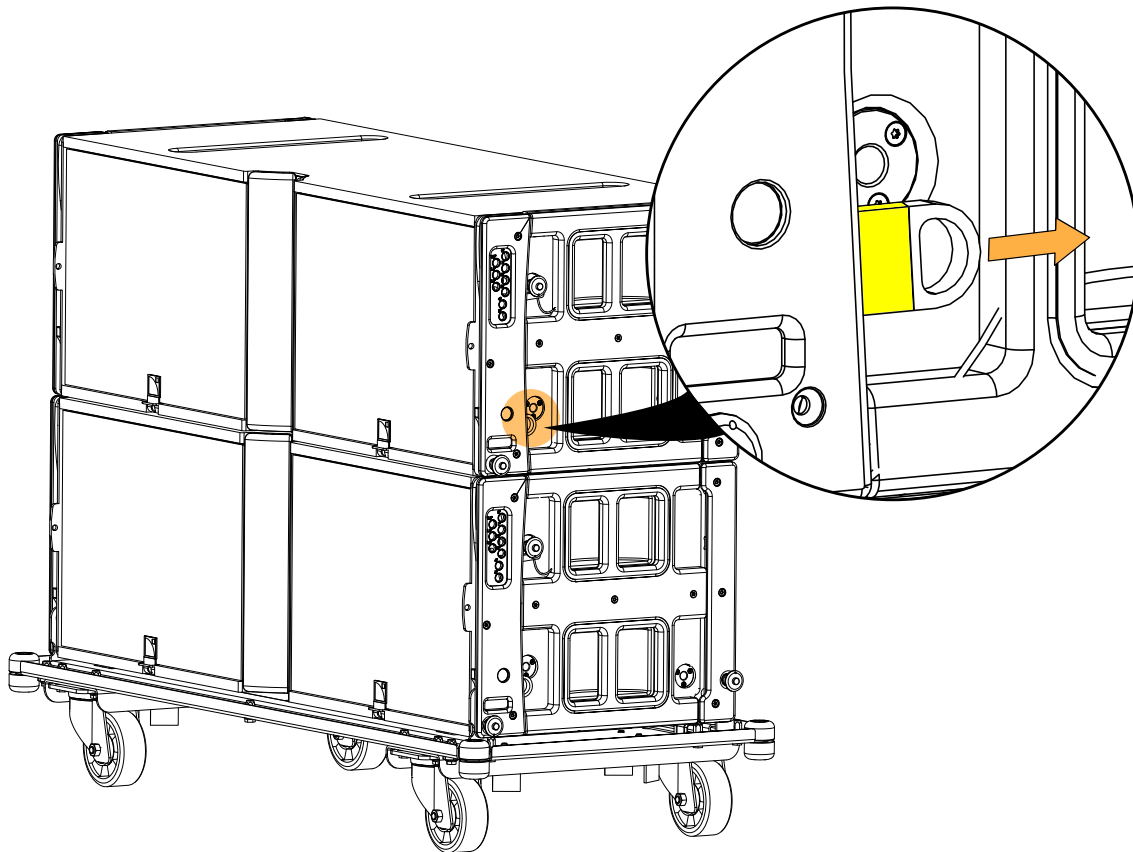

2. If necessary, on each side of the bottom enclosure, remove the ball-locking pin from its current angle hole.

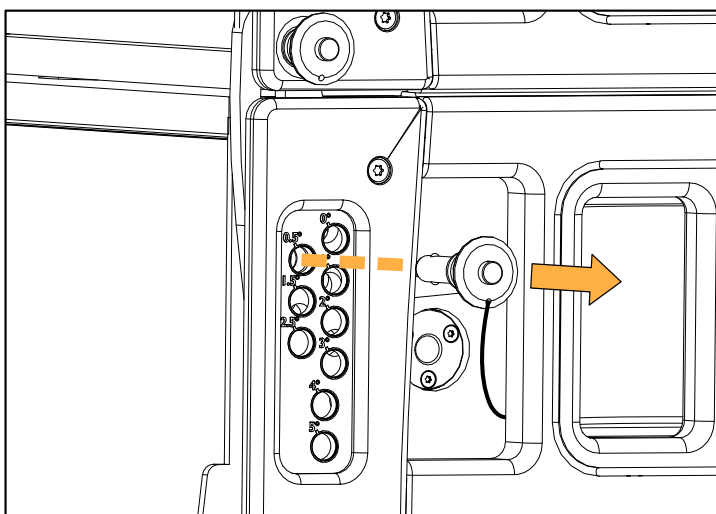

- Slide out the front rigging arm to the desired angle hole and insert the ball-locking pin.

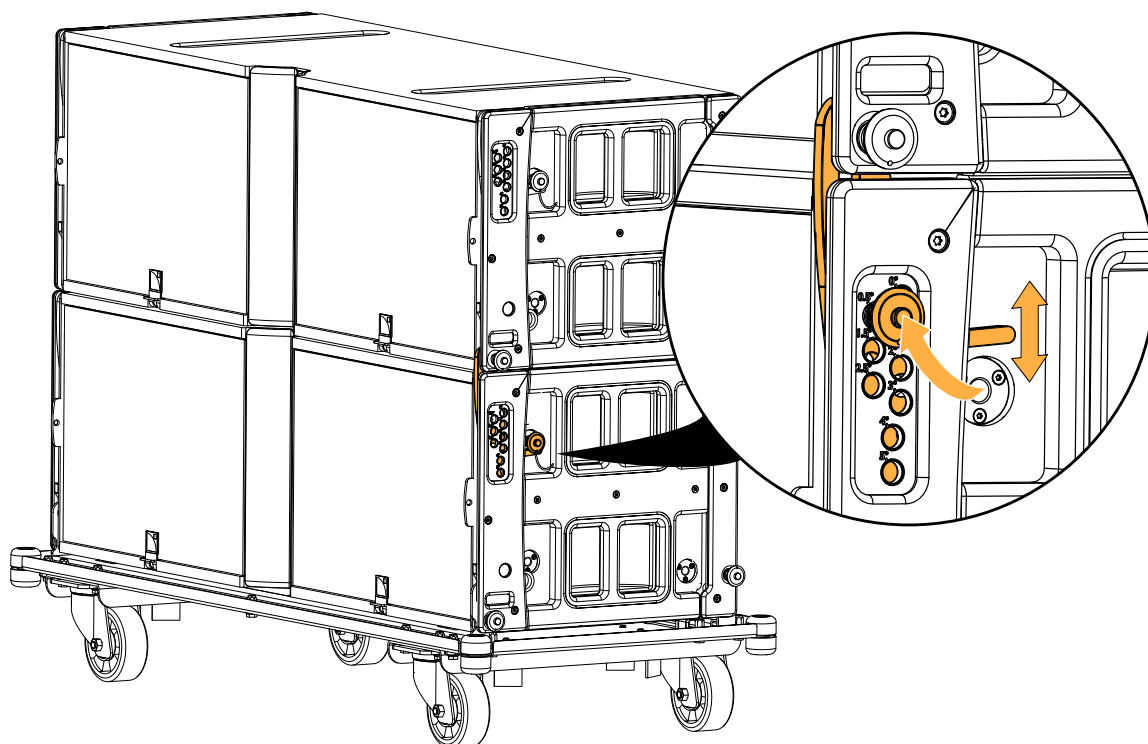

- On each side of the top enclosure, press the angle locking button to lock the inter-enclosure angle. The latch slightly retracts when the button is pushed (yellow label visible).

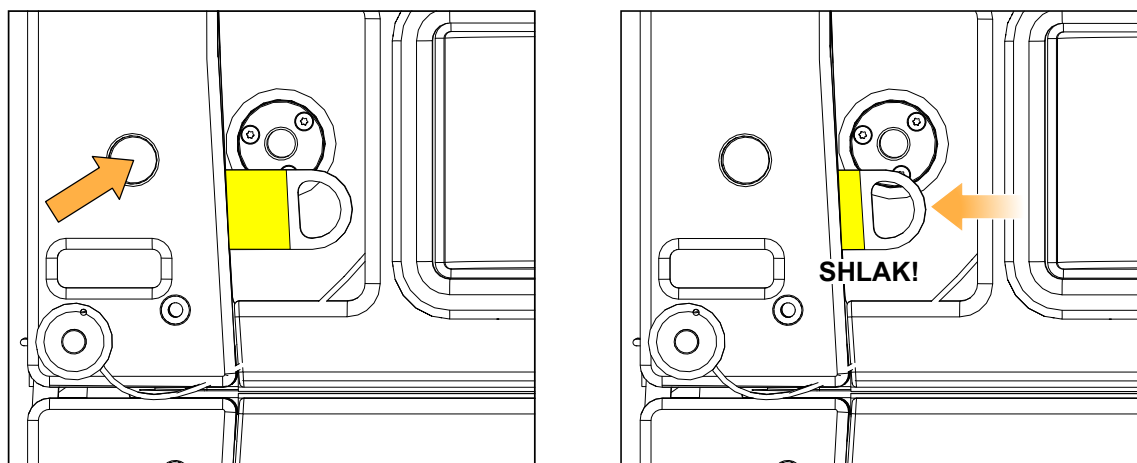

- Repeat the procedure for each inter-enclosure angle of the array.

Flying K1

Flying a K1/K1-SB array with K1-BUMP

Min number of operators	3
Rigging accessories	4 Ø 22 mm shackles WLL 3.25 t K1-BUMP

- !** **All along the procedure:**
Systematically ensure that each ball-locking pin is fully inserted by pulling on it.
- !** For clarity purposes, the loudspeaker cable procedure is not described.
The loudspeaker cables are not represented in the figures.
- i** Follow the same procedure for K1-SB enclosures.

Prerequisite

- Prepare K1-BUMP. Refer to [Preparing K1-BUMP](#) (p.62).
- If necessary, secure LA-RAK II AVB on K1-BUMP. Refer to [Securing LA-RAK II AVB on K1-BUMP](#) (p.67).
- Prepare a block of four K1. Refer to [Preparing a block of four K1/K1-SB](#) (p.71).
- Preset the inter-enclosure angles. Refer to [Presetting the inter-enclosure angles of K1/K1-SB](#) (p.74).

Procedure

1. Lift K1-BUMP to more than 2 m / 6.5 ft height using the motor.
2. Position a block of four K1/K1-SB under K1-BUMP.
3. Secure K1-BUMP on top of the array:
 - a) On each side of the K1-BUMP rigging frame, remove the four ball-locking pins.

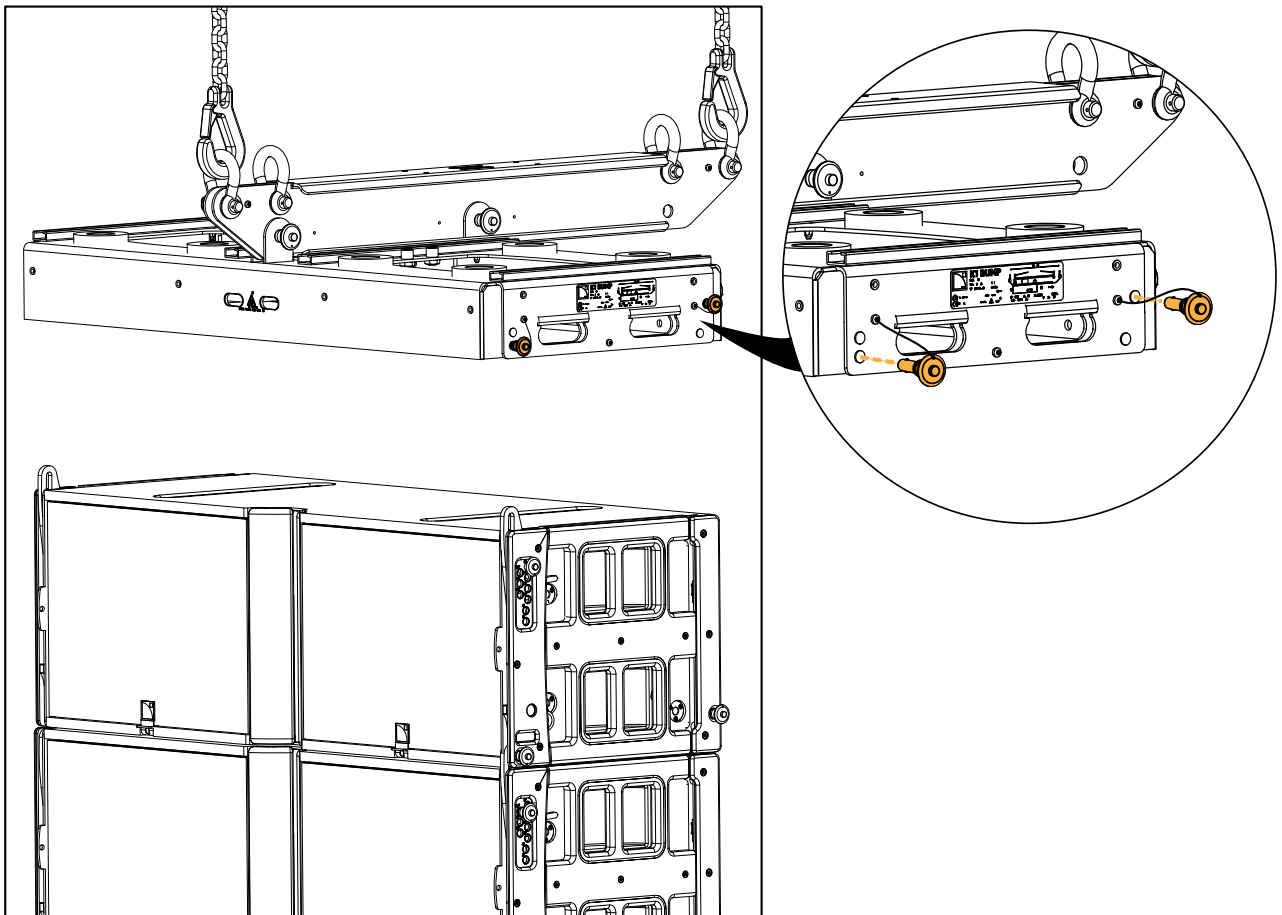

b) Lower K1-BUMP to facilitate the connection between the enclosures and the rigging frame.

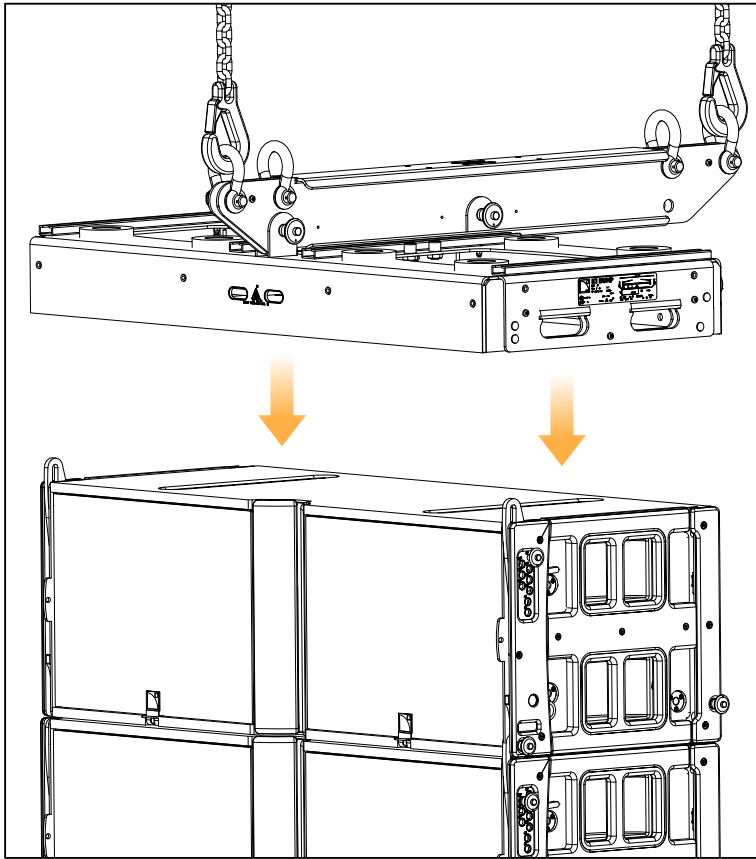

c) On each side of the top enclosure, secure the front rigging arm using the K1-BUMP ball-locking pin.

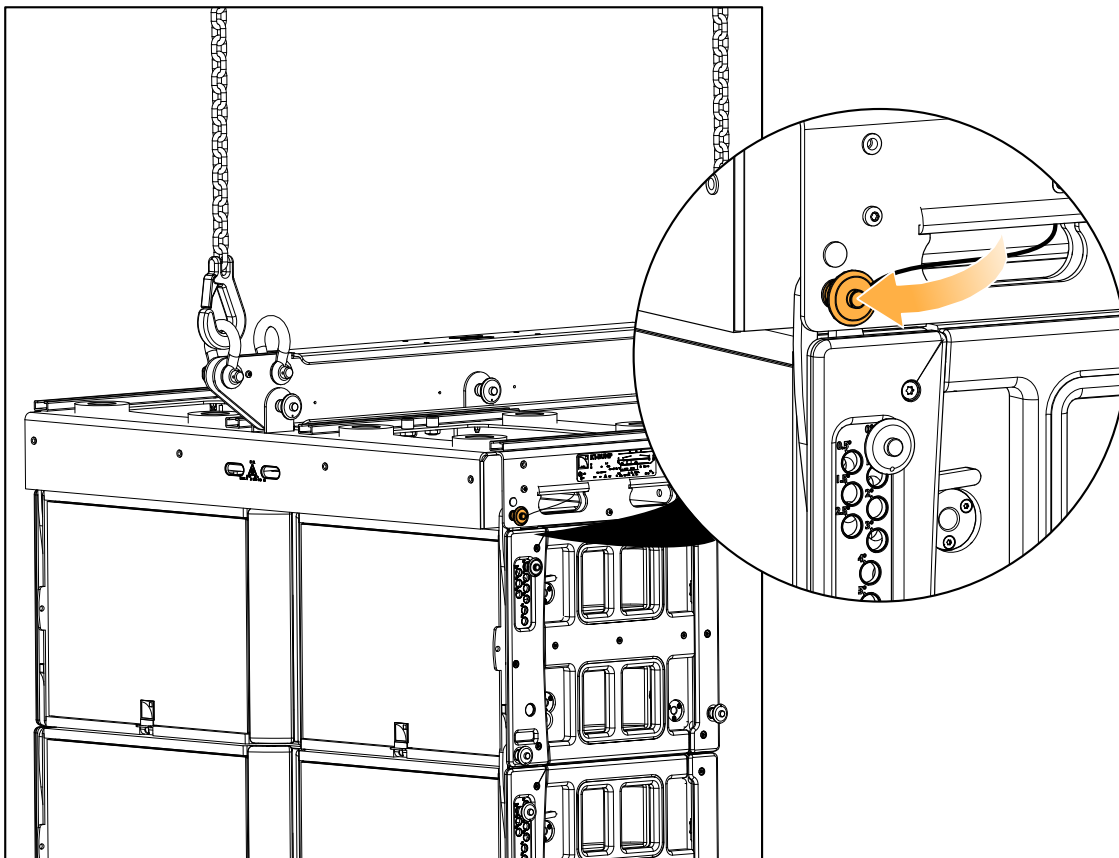

d) On each side of the top enclosure, rotate the rear rigging arm and secure it using the K1-BUMP ball-locking pin.

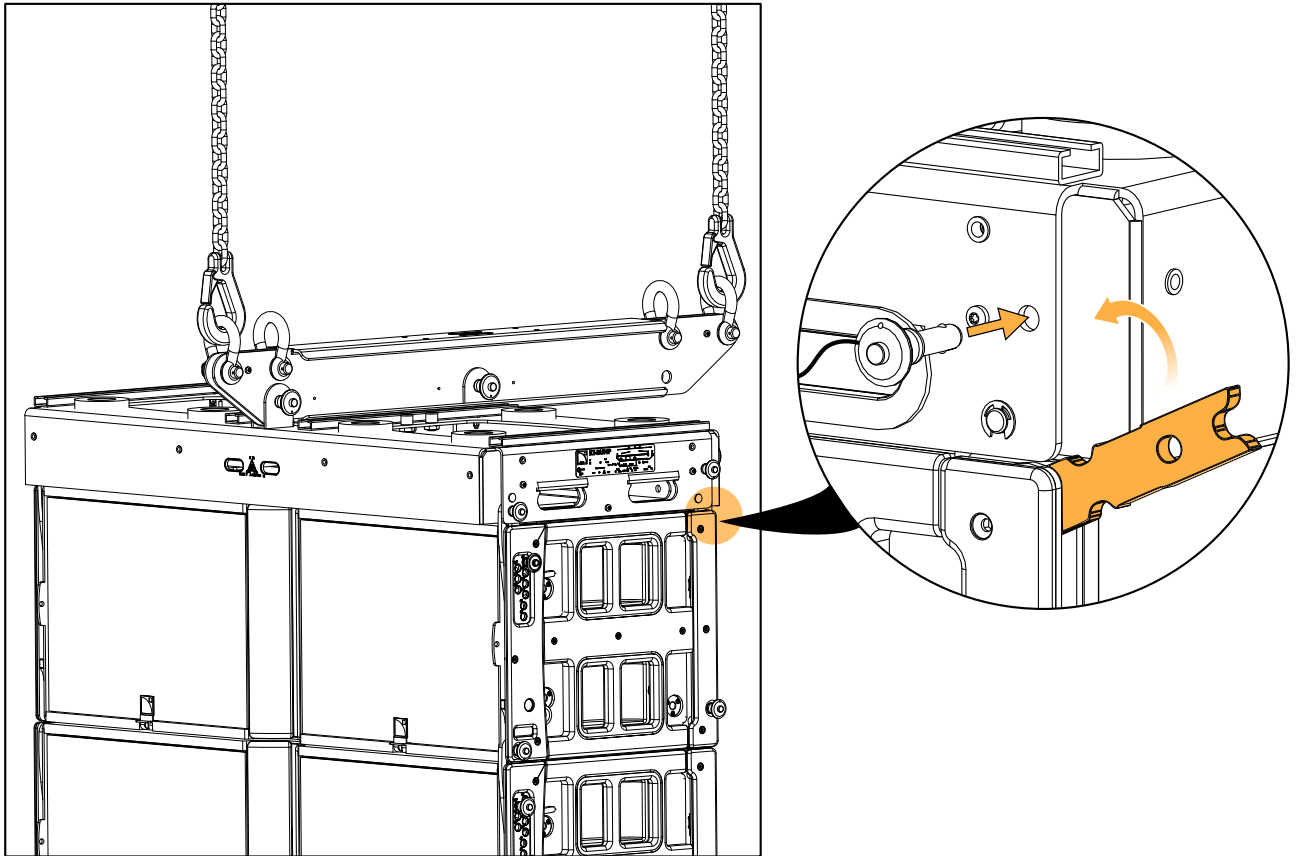

4. Before raising the array, check that all ball-locking pins and rigging arms are properly secured.



Check that all ball-locking pins are **fully inserted** in rigging position.

Check that all rear rigging arms are secured by making sure **no yellow sticker is visible**.

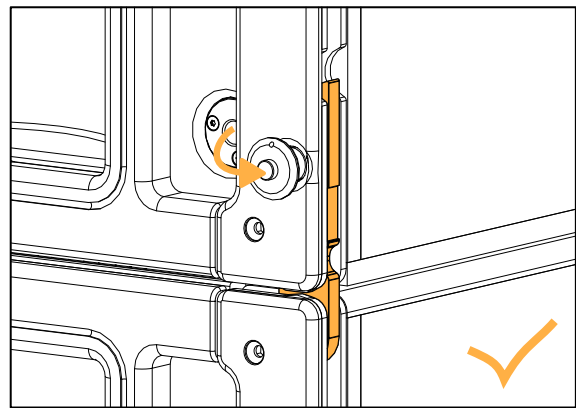
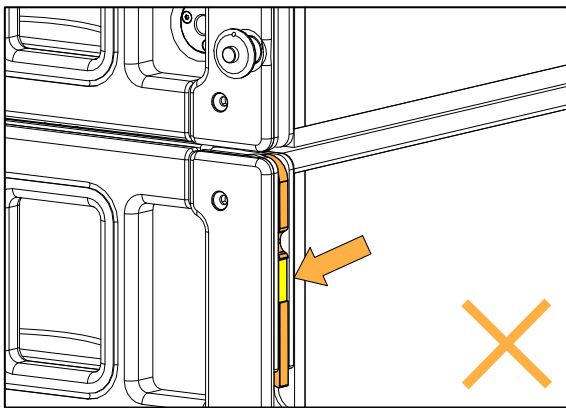

5. Slightly raise the array to lock the inter-enclosure angles.
The automatic system engages and the latches retract (except on the bottom enclosure).



Check that the automatic locking system is **activated**.

When the automatic locking system is activated, **no yellow sticker is visible** on the latches.

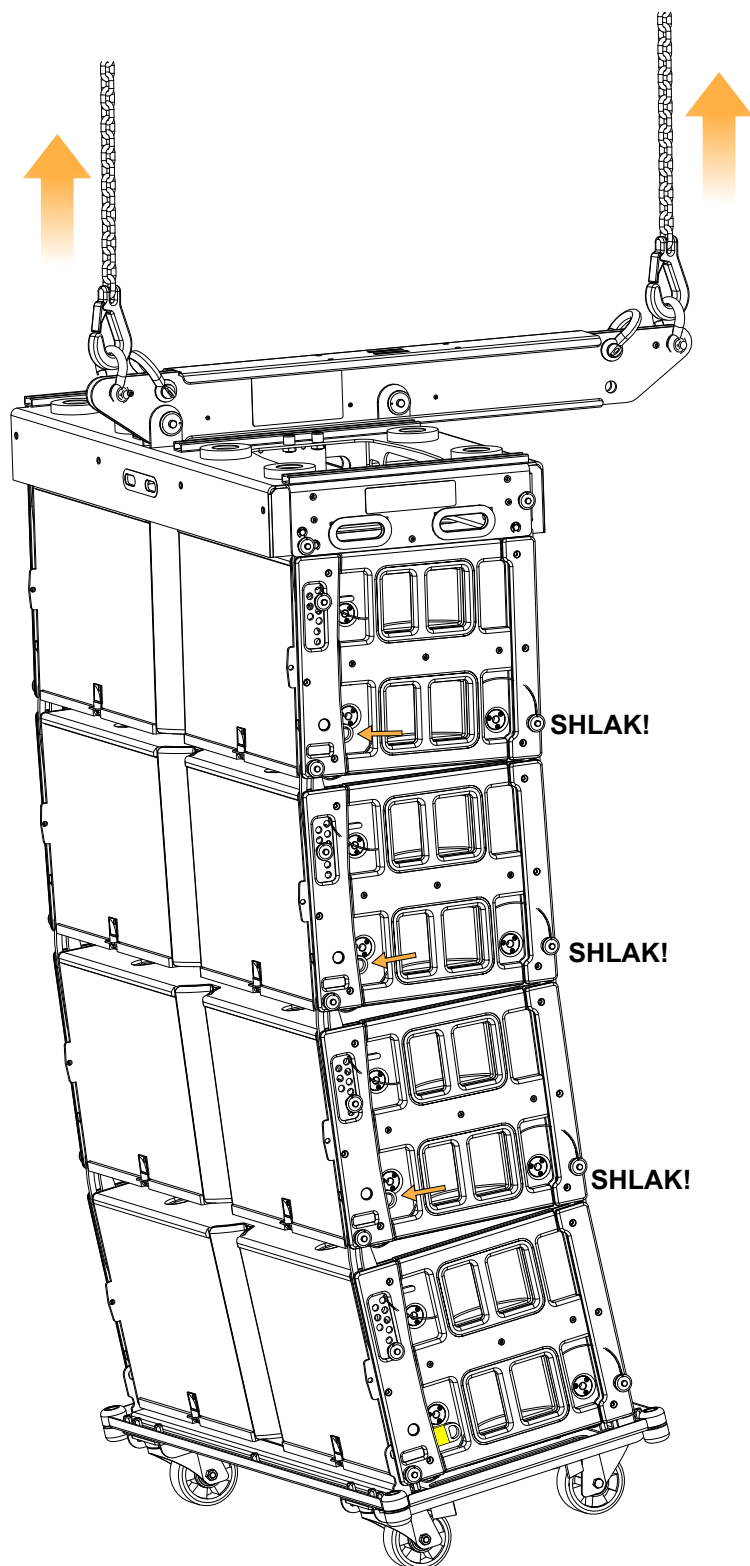

6. Remove K1-CHARIOT from the array:

a) Hold K1-CHARIOT and remove the two front ball-locking pins. Put them into their storage locations.

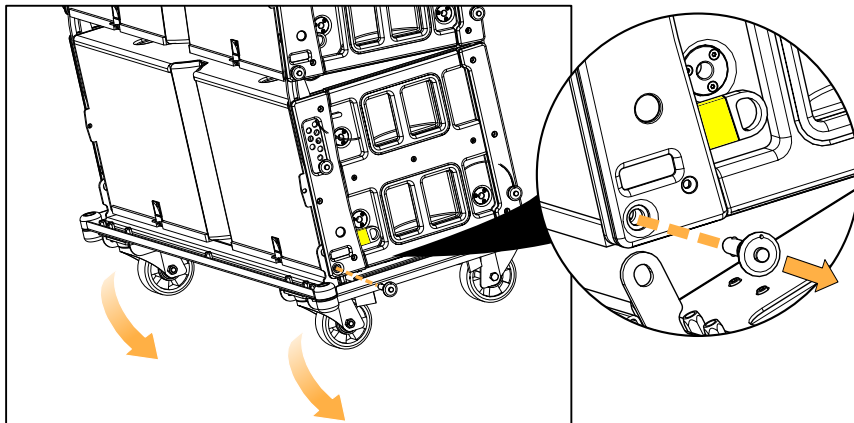

b) Hold K1-CHARIOT and remove the two rear ball-locking pins. Put them into their storage locations.

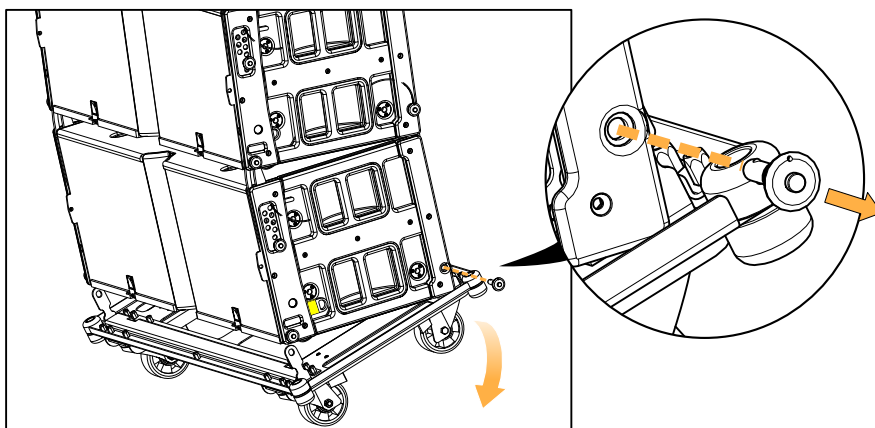

What to do next

- Attach a block of four K1 under the array. Refer to [Attaching a block of four K1 under a K1 array](#) (p.81).
- Add a Kara II downfill array. Refer to [Rigging a Kara II downfill array under a K1 array with KARA-DOWNK1](#) (p.92).

Attaching a block of four K1 under a K1 array

Min number of operators	3
Rigging accessories	2 Ø 22 mm shackles WLL 3.25 t K1-BUMP



All along the procedure:

Systematically ensure that each ball-locking pin is fully inserted by pulling on it.



Secondary safety

Use available holes on the rigging accessories to implement a secondary safety.

Prerequisite

- Prepare a block of four K1. Refer to [Preparing a block of four K1/K1-SB](#) (p.71).
- Preset the inter-enclosure angles. Refer to [Presetting the inter-enclosure angles of K1/K1-SB](#) (p.74).

Procedure

1. Position the block of four K1 under the array.
2. On each side, secure the front rigging arm:
 - a) Lower the array to align the front rigging points.

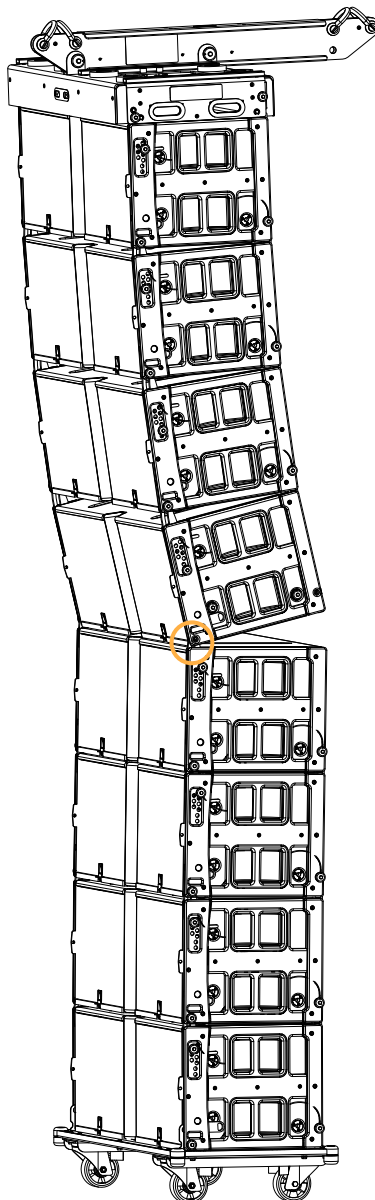

- b) Secure the front rigging arms using the ball-locking pins.
If necessary, slide the front rigging arms to align the holes.

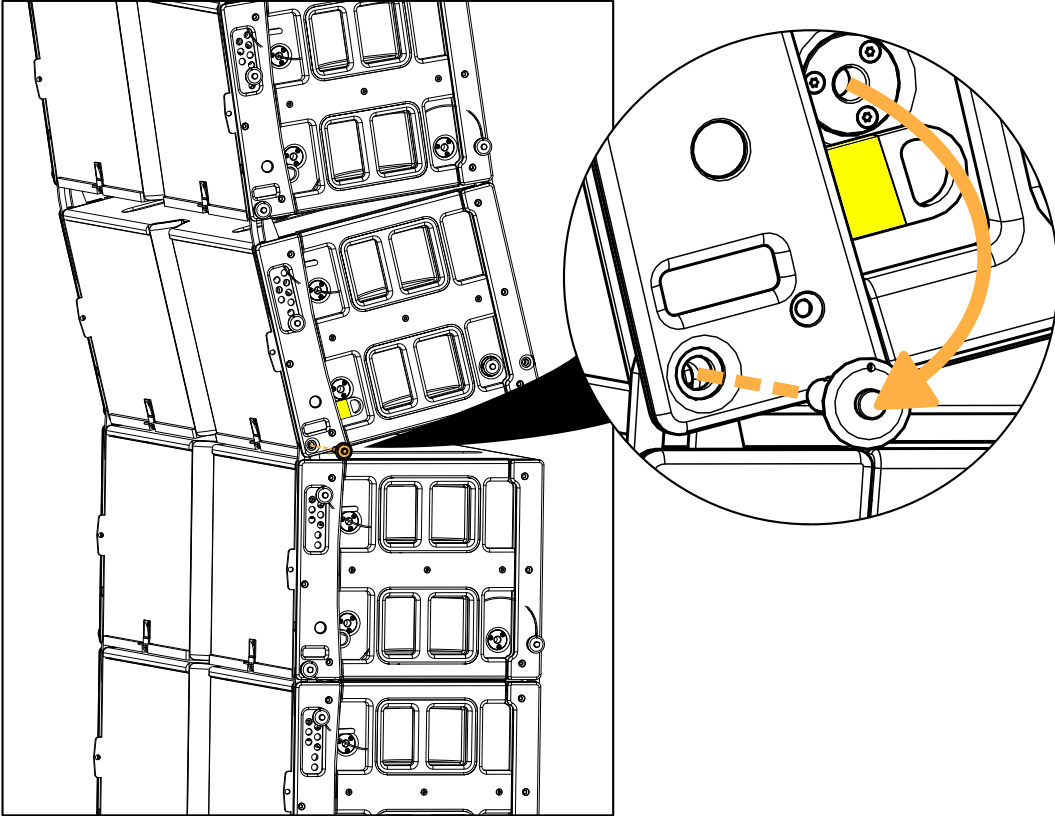

3. Press the angle locking buttons to lock the inter-enclosure angles.
The latches slightly retract when the buttons are pushed (yellow label visible).

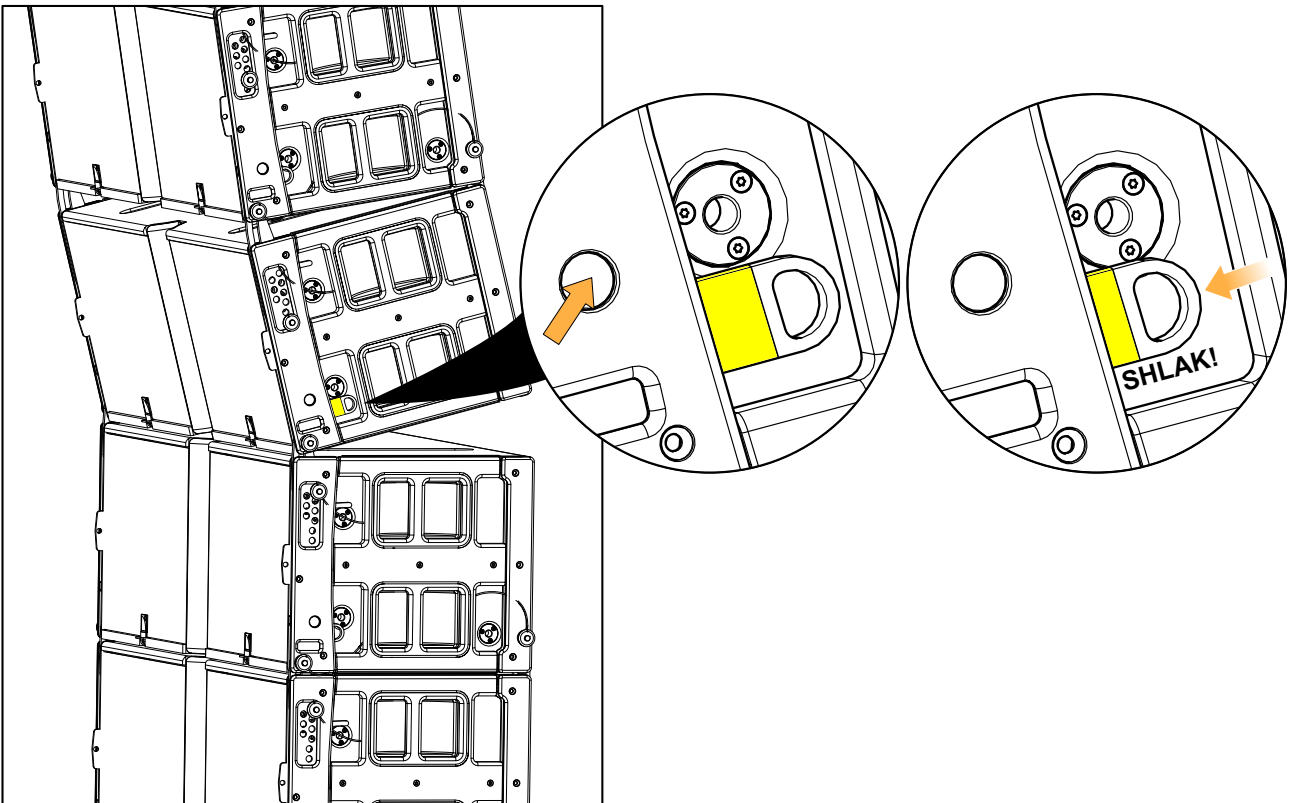

4. Raise the array until the K1-CHARIOT wheels are off the ground.
The latches engage and **no yellow sticker is visible**, except on the bottom enclosure.

5. Turn the wheels inside the chariot.

! This operation avoids instability when the wheels are in contact with the ground.

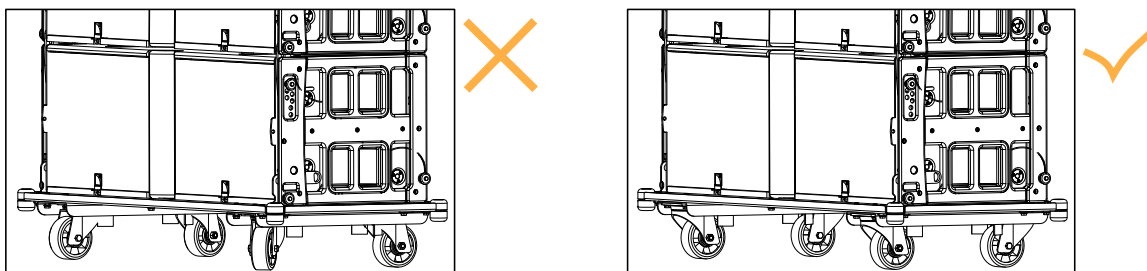

6. On each side, secure the rear rigging arms:

a) Pull the array towards the back while lowering it until the rear corners are in contact.

! Three people are needed for this operation:
 One manipulating the hoist controller,
 Two on both sides of the array, grabbing the handles of the bottom enclosure.

! Stop lowering the array when both rear corners are in contact.
 This operation avoids putting too much stress on the K1-CHARIOT wheels.

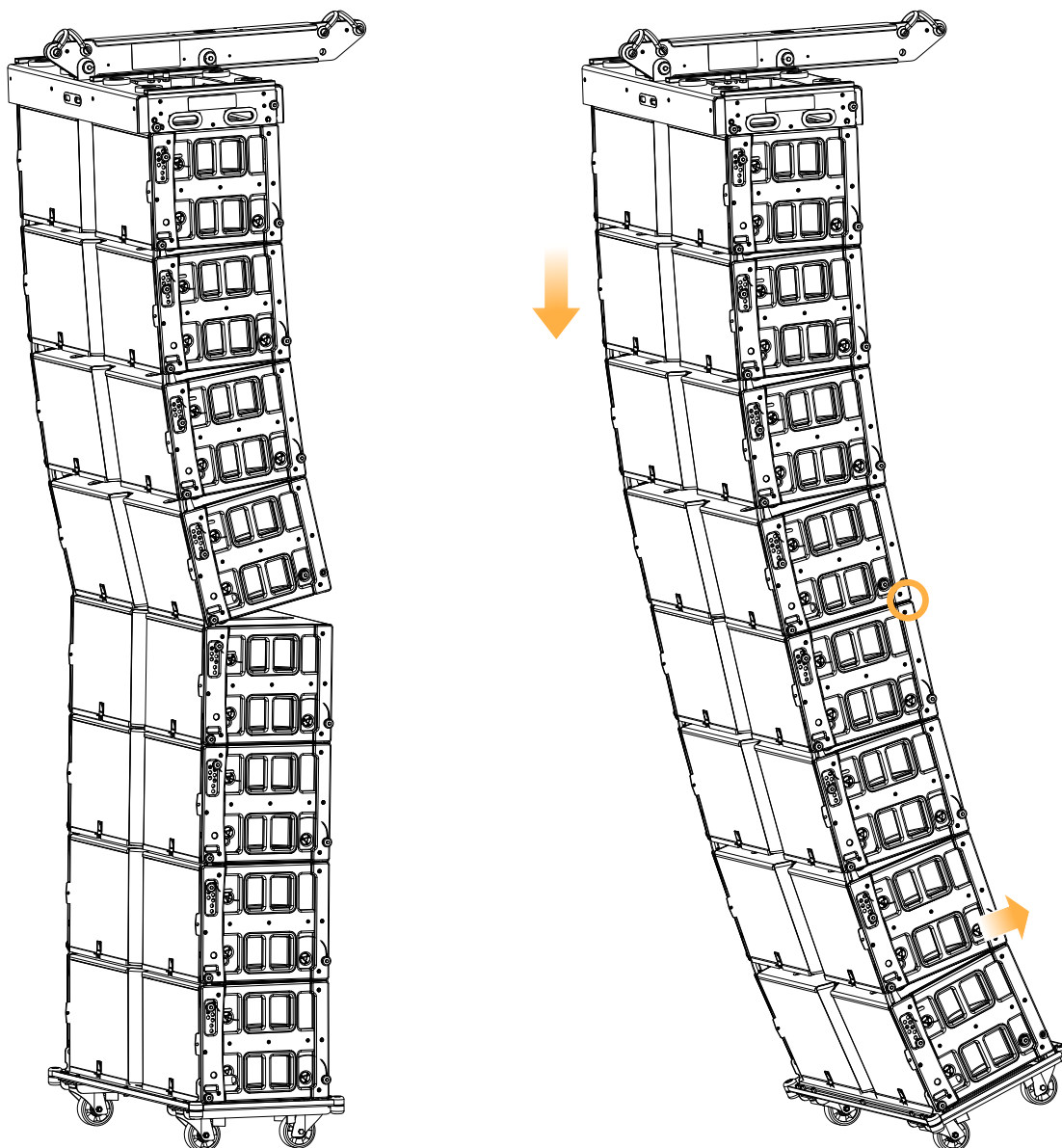

b) Rotate the two rear rigging arms of the top enclosure and secure them to the array.

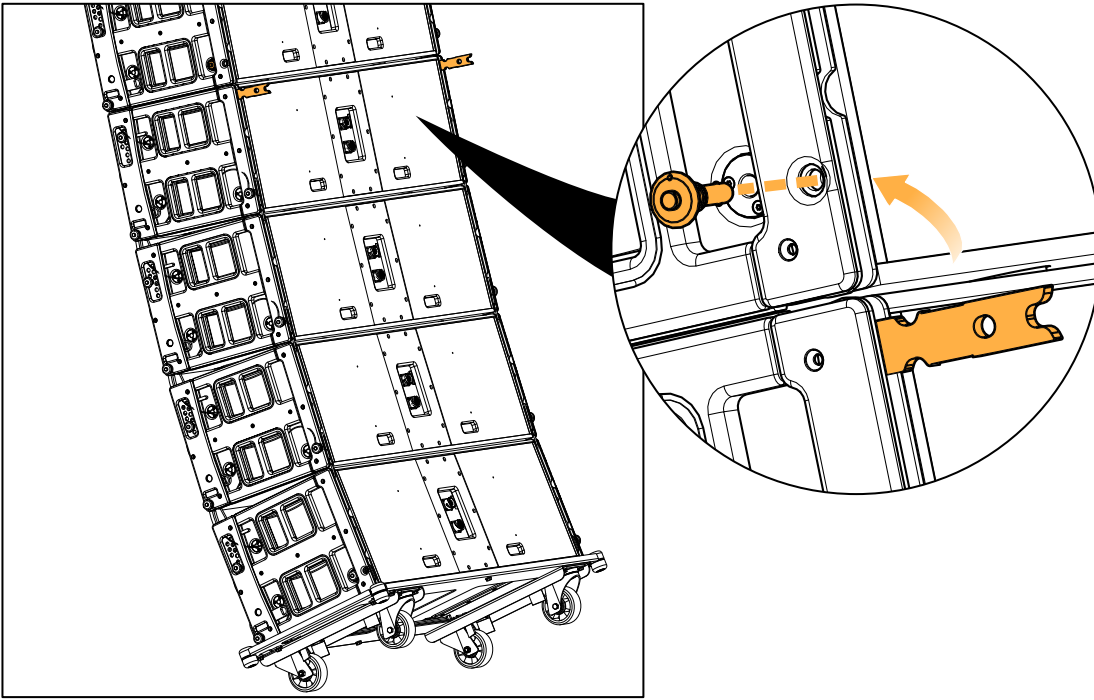

7. Raise the array until the K1-CHARIOT wheels are off the ground.

8. Remove K1-CHARIOT from the array:

a) Hold K1-CHARIOT and remove the two front ball-locking pins. Put them back into their storage locations.

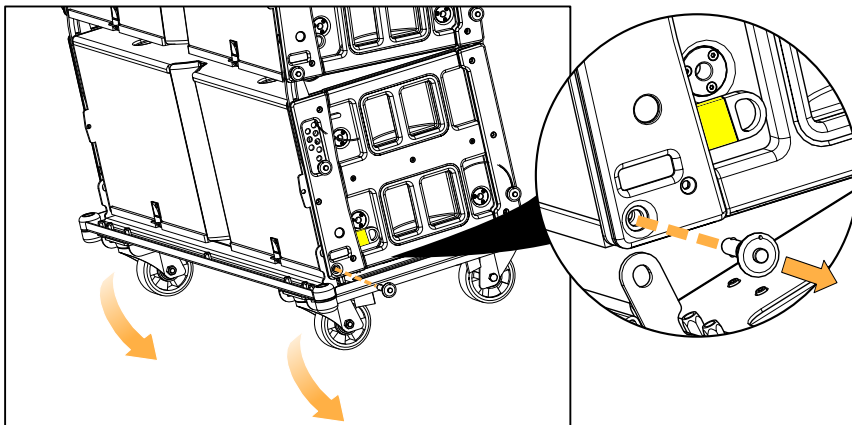

b) Hold K1-CHARIOT and remove the two rear ball-locking pins. Put them back into their storage locations.

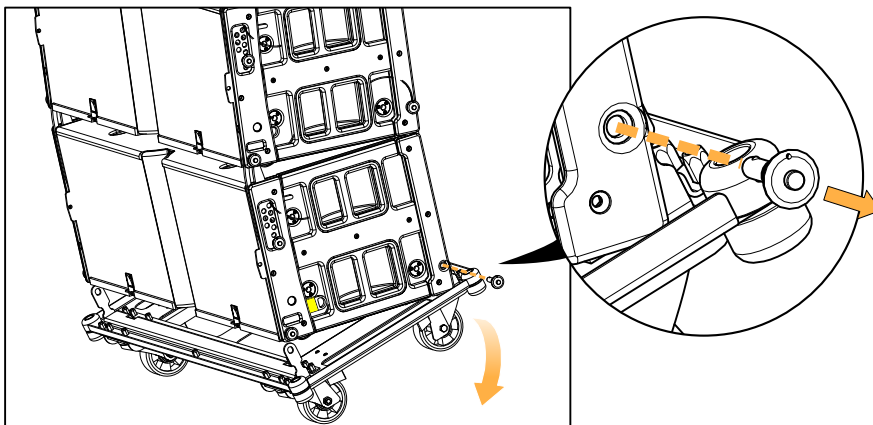

9. Repeat the procedure until the array is complete.

10. Fly the array at desired trim height and adjust the site and azimuth angles.

Attaching a block of four K2 under a K1/K1-SB array

Min number of operators	3
Rigging accessories	4 Ø 22 mm shackles WLL 3.25 t K2-LINK

! **All along the procedure:**
Systematically ensure that each ball-locking pin is fully inserted by pulling on it.

! **K1 / K1-SB must always be on top of a K2 array.**

i K2 arrays can be flown with K1-BUMP or K2-BUMP.
Refer to the **K2 owner's manual** for the procedure with K2-BUMP.

i Follow the same procedure for K1-SB enclosures.

Prerequisite

- Prepare a block of four K1. Refer to [Preparing a block of four K1/K1-SB](#) (p.71).
- Preset the inter-enclosure angles. Refer to [Presetting the inter-enclosure angles of K1/K1-SB](#) (p.74).
- Prepare a block of four K2 and preset the inter-enclosure angles. Refer to the **K2 owner's manual**.

Procedure

1. Position the block of four K2 under the array.

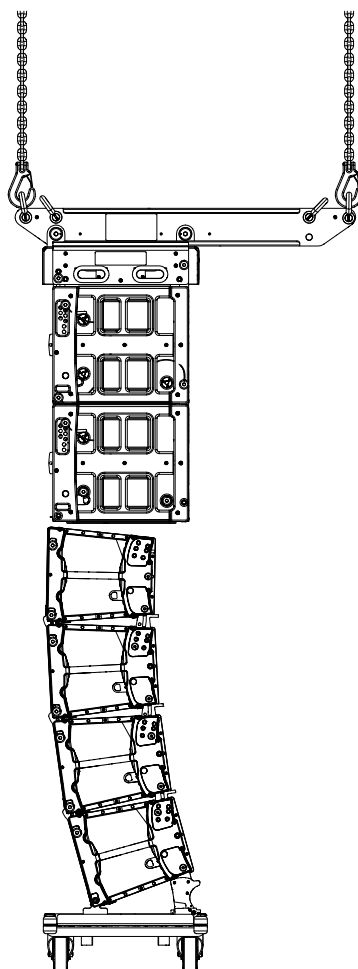

2. On each side, secure the front rigging arm:

- a) Rotate the front rigging arm to align its hole with the K1/K1-SB rigging hole.

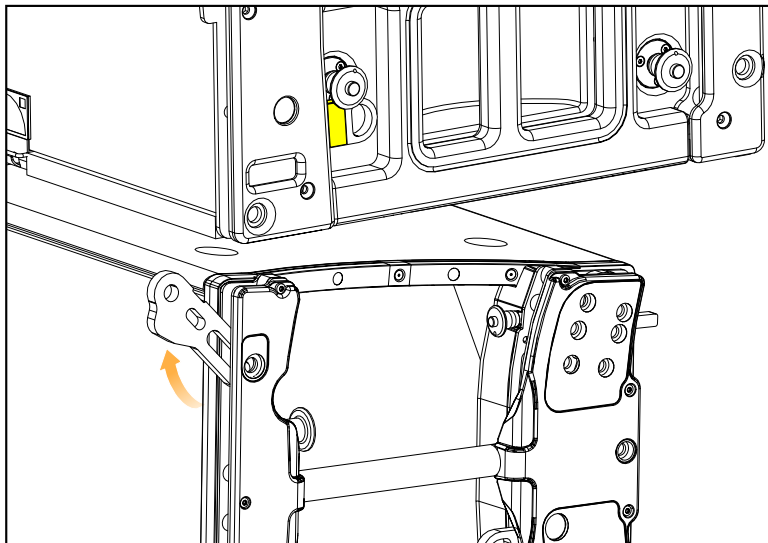

- b) Secure the front rigging arm using the ball-locking pin

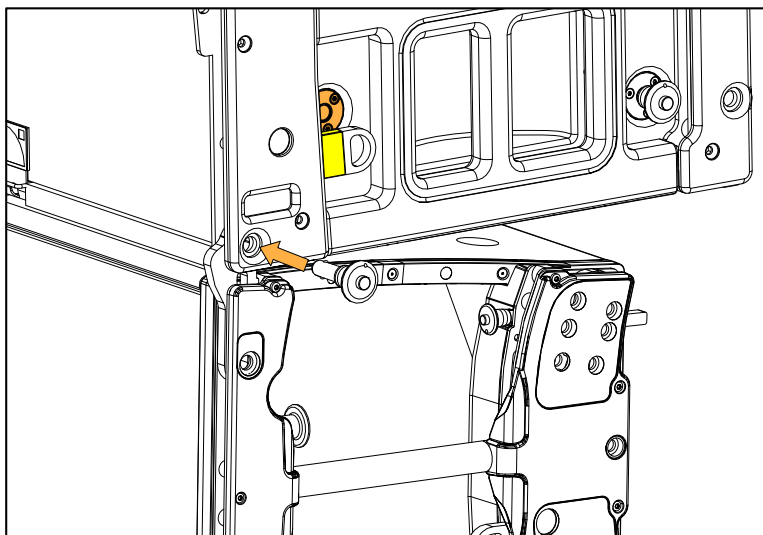

- c) Lower the flown array and secure the assembly using the ball-locking pin.

i If necessary, move the flown array back and forth holding the enclosure handles to insert the ball-locking pin.

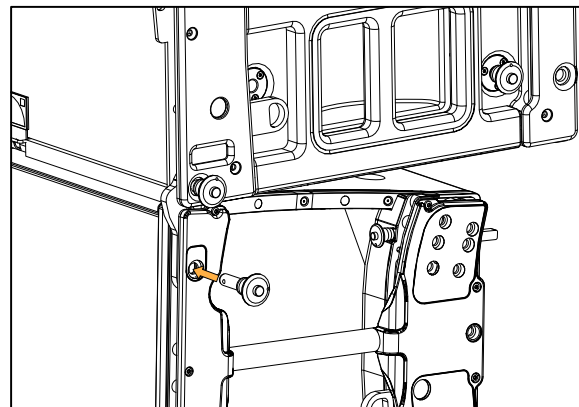
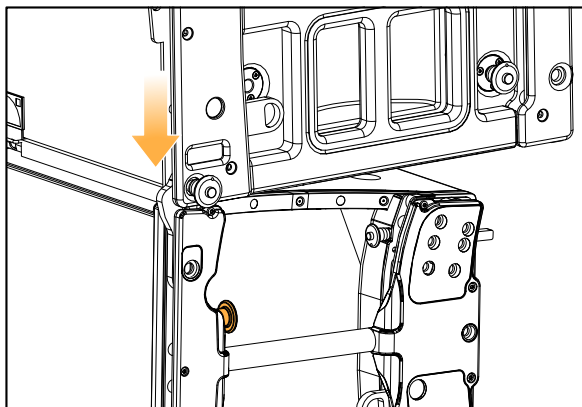

3. Before raising the array, check that all ball-locking pins and rigging arms are properly secured.



Check that all ball-locking pins are **fully inserted** in rigging position.

Check that all rear rigging arms are secured by making sure **no yellow sticker is visible**.

4. Slightly raise the array to lock the inter-enclosure angles.

The array swings.

The automatic system engages and the latches retract (except on the bottom enclosure).



Check that the automatic locking system is **activated**.

When the automatic locking system is activated, **no yellow sticker is visible** on the latches.

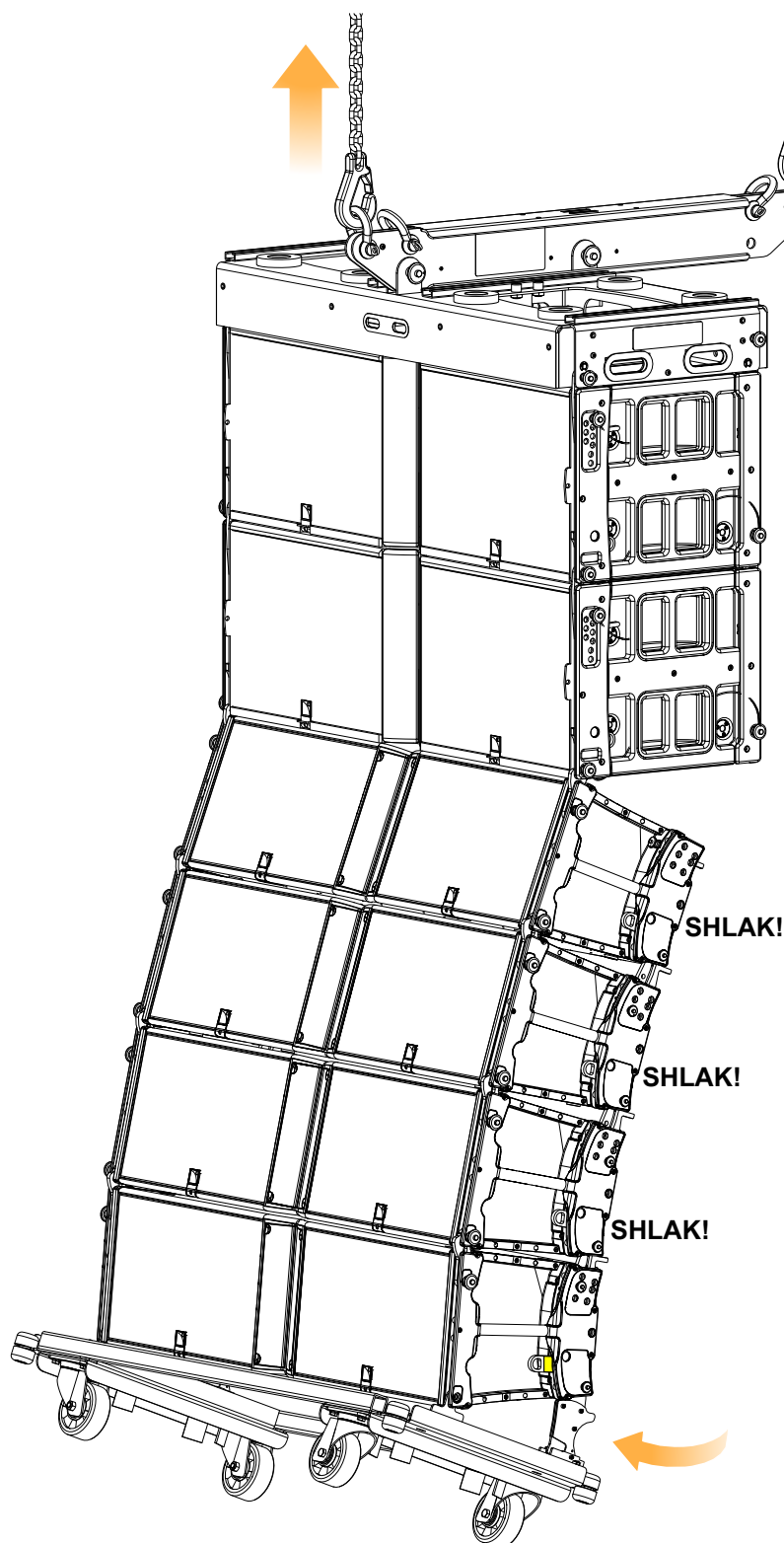

5. Turn the front wheels inside K2-CHARIOT.

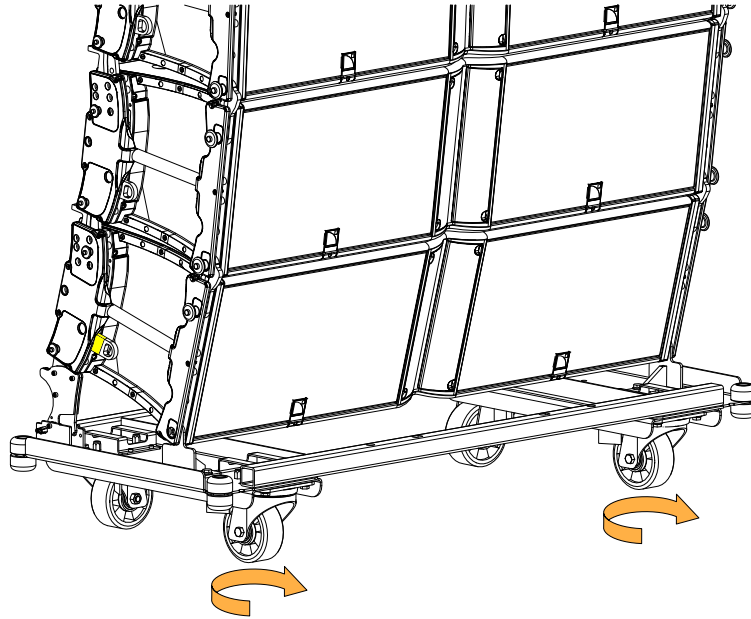

6. Connect the rear of the K1/K1-SB array to the rear of the K2 array with the K2-LINK interfaces:
a) On each side, attach a K2-LINK at the back of the K1/K1-SB enclosure.

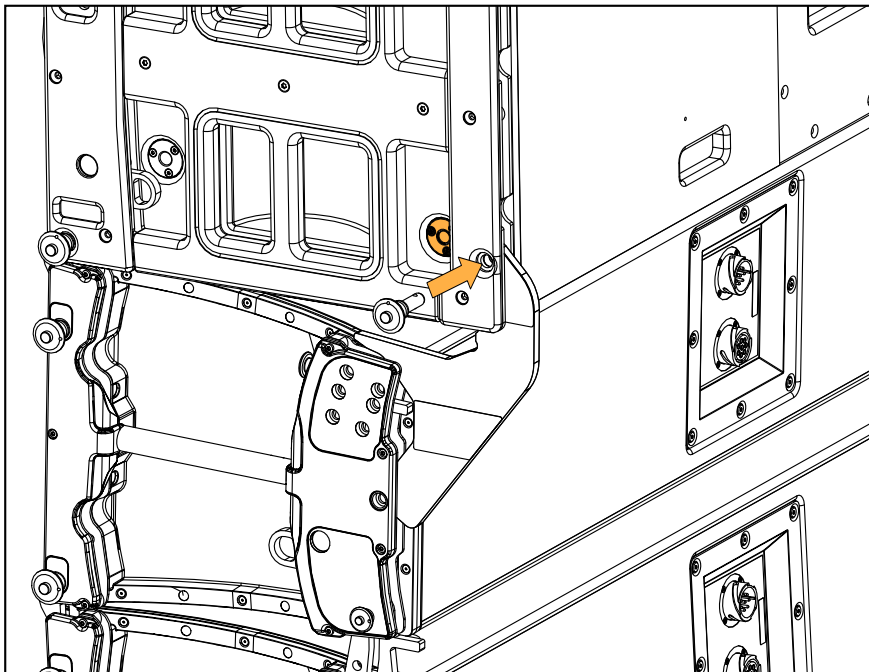

i Do not pin K2-LINK on K2 yet.

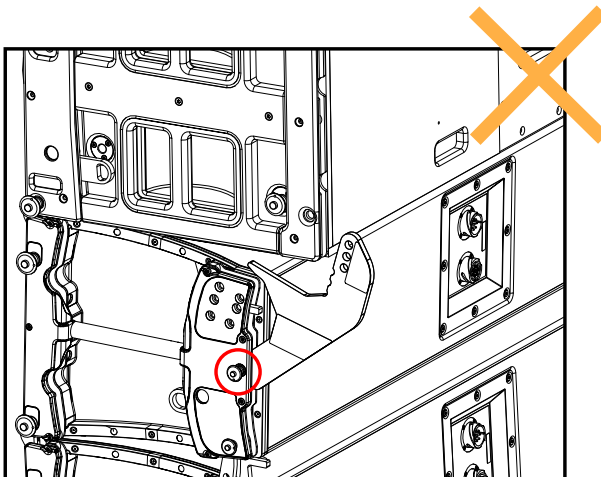

b) Pull back the bottom enclosures while lowering the array until only the front wheels touch the ground.

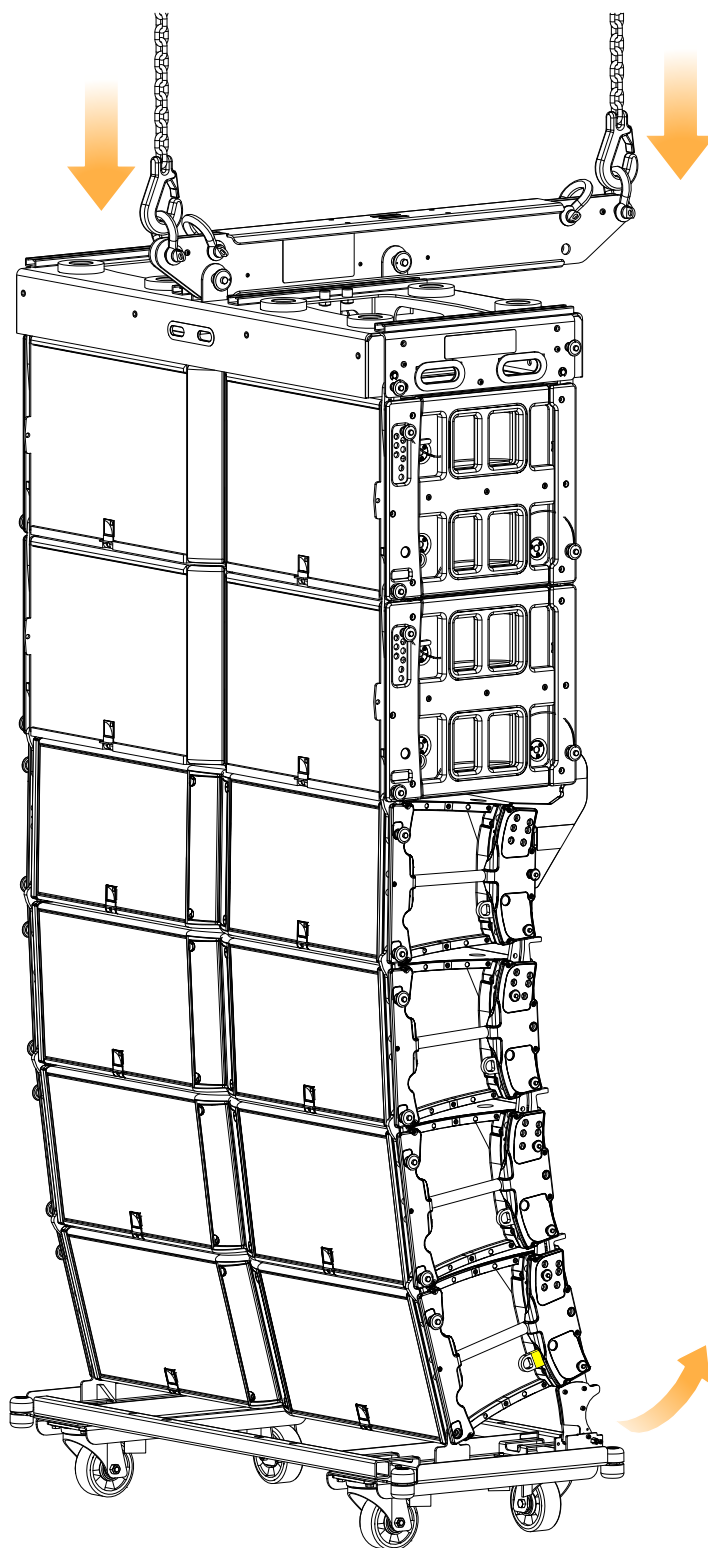

c) Push the K2-LINK into the K2 rear rigging.

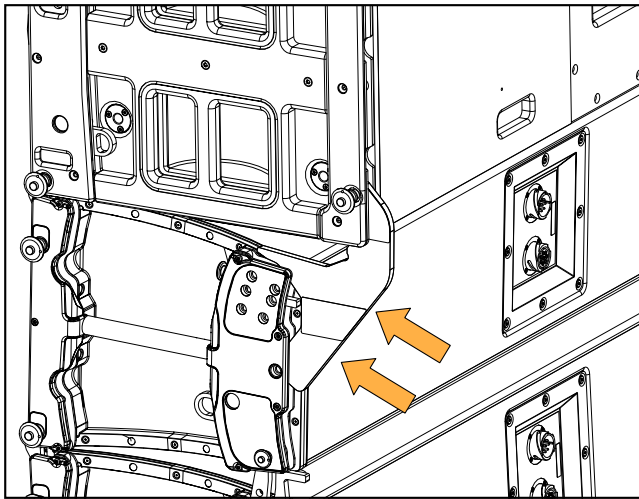

7. Lower the array until the hole of K2-LINK matches the K2 rigging middle hole.



Risk of pinching

Do not touch K2-LINK while lowering the array.

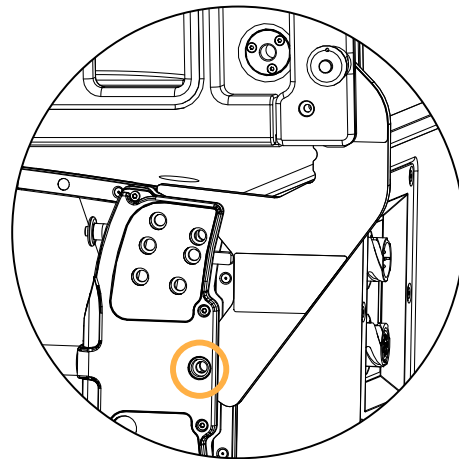
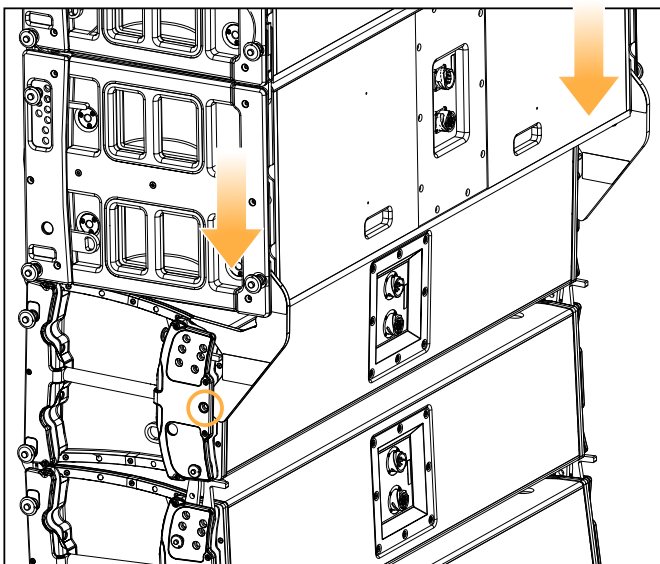

8. Secure K2-LINK on the K2 rigging middle hole.

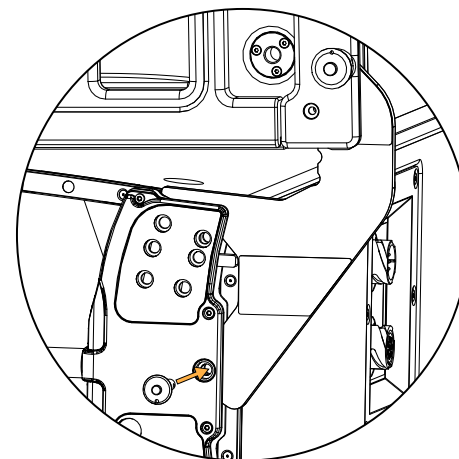
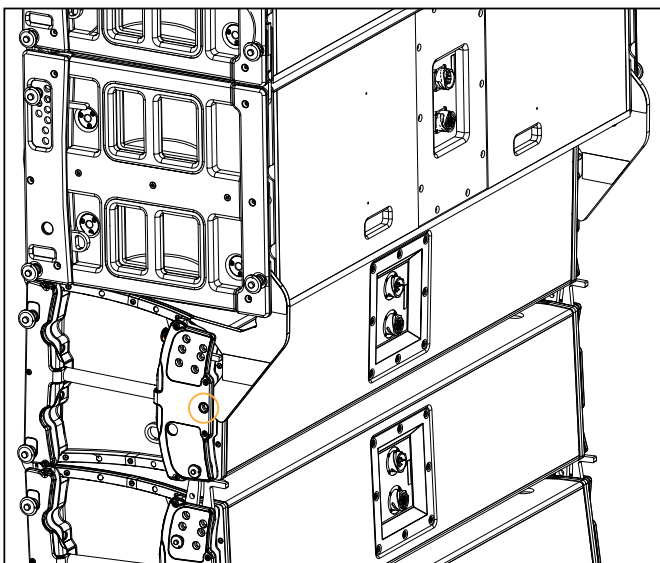

9. Raise the array until the K2-CHARIOT wheels are off the ground.

10. Remove K2-CHARIOT from the array:

- a) Hold K2-CHARIOT and remove the two rear ball-locking pins. Put them back into their storage locations .

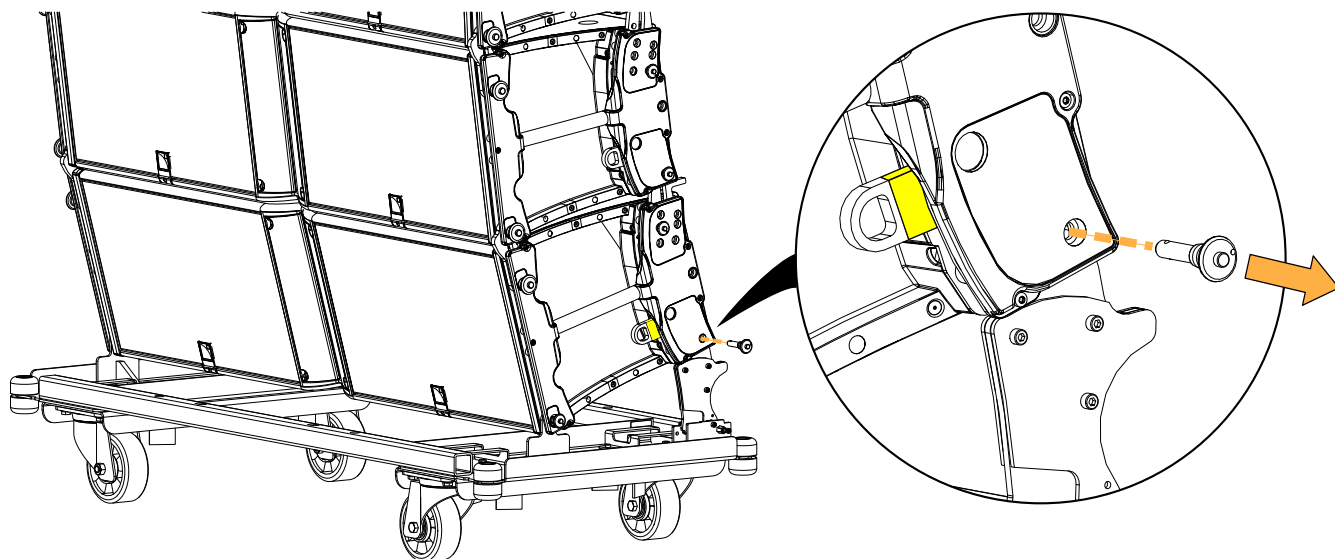

- b) Hold K2-CHARIOT and remove the two front ball-locking pins. Put them back into their storage locations .

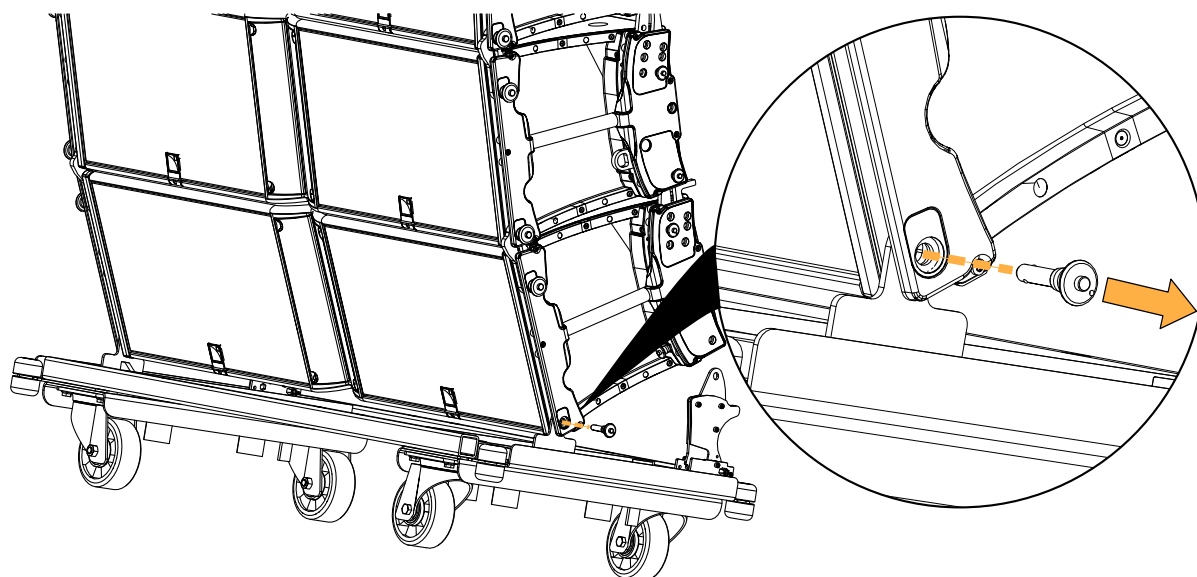

Rigging a Kara II downfill array under a K1 array with KARA-DOWNK1

Min number of operators	2
Rigging accessories	KARA-DOWNK1

Prerequisite

- Prepare and raise a K1 array. Refer to [Flying K1](#) (p.76).
- Prepare an array of three Kara II with 0° inter-enclosure angles. Refer to the **Kara II owner's manual**.
- Position the Kara II array under the K1 array.

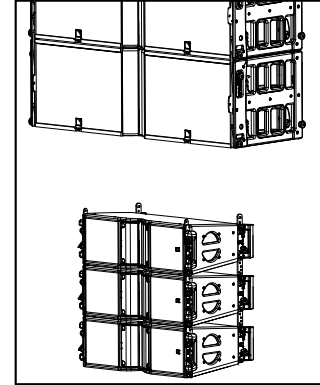

Procedure

1. On each side of the top Kara II enclosure, set the front rigging arm into rigging position:
 - a) Rotate and slide down the front rigging arm.
 - b) Secure the front rigging arm with the ball-locking pin.

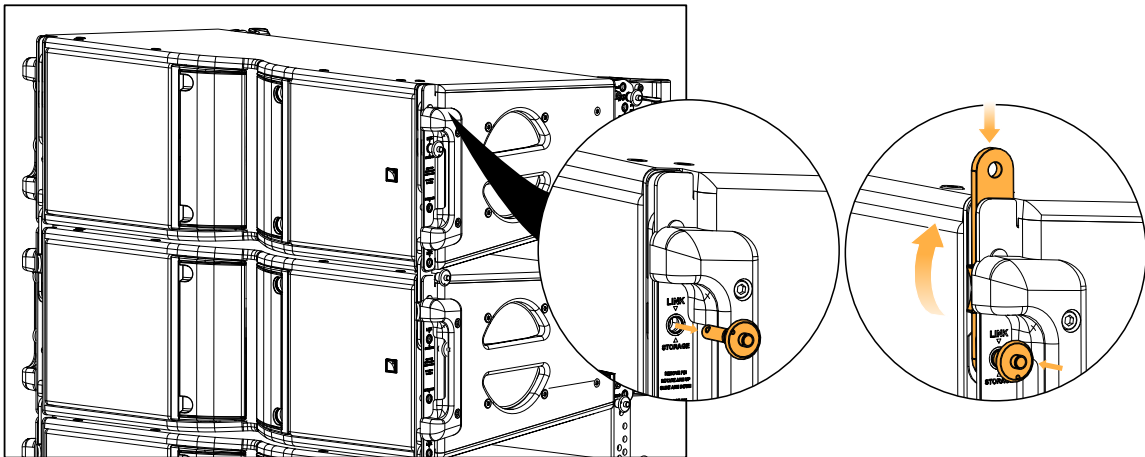

2. On each side of the top Kara II enclosure, set the rear rigging arm into rigging position:
 - a) Slide up the rear rigging arms and select the same inter-element angle, from 0° to 10°.
 - b) Secure the rear rigging arm with the ball-locking pin.

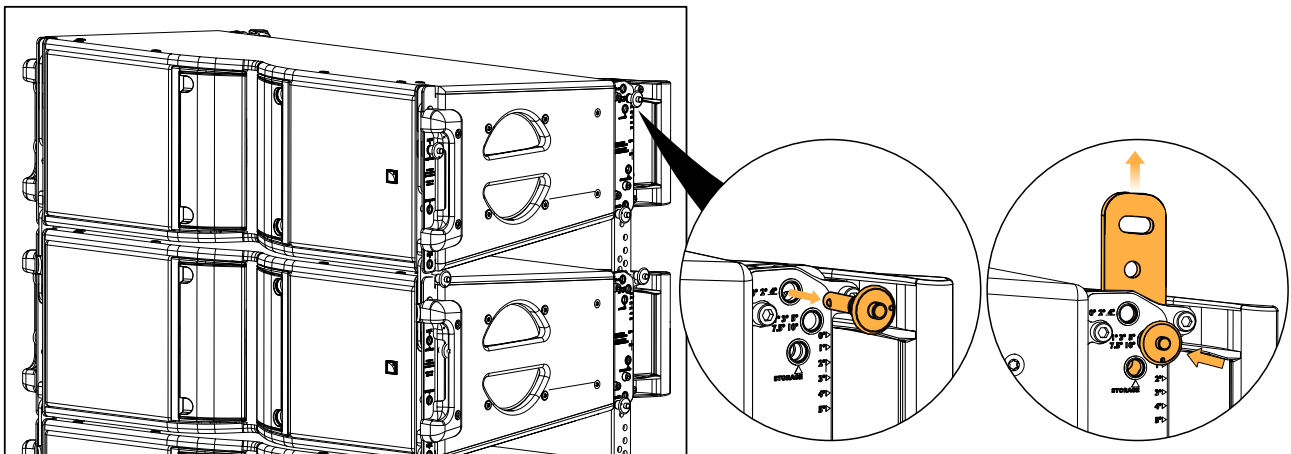

3. Secure KARA-DOWNK1 on top of the Kara II array.

! Position the higher ledge at the rear.

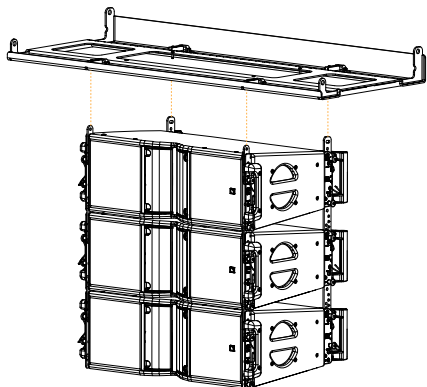

Secure the four Kara II rigging arms inside the slits using the ball-locking pins.

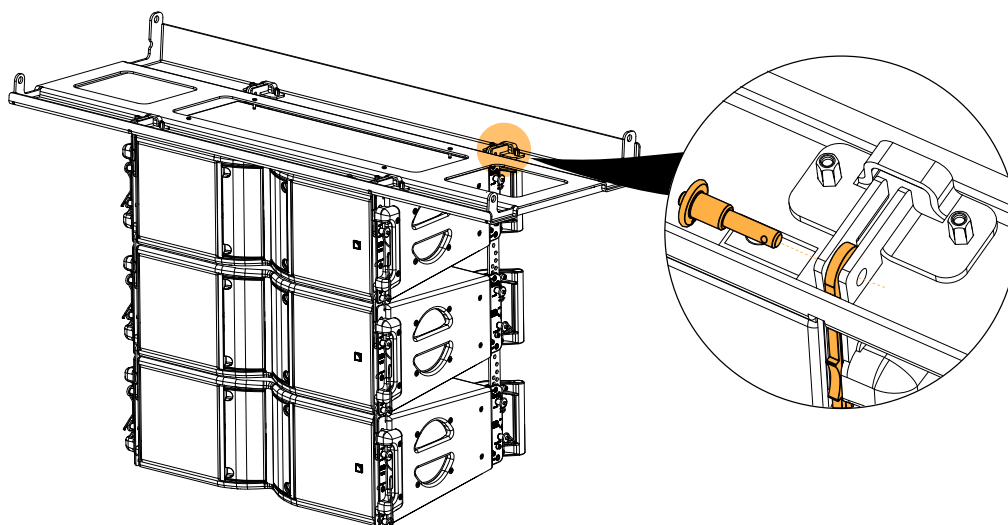

4. Lower the K1 array as close as possible to the assembly without resting on it.
 5. Disconnect the rear ball-locking pins between the two top Kara II enclosures and place them in storage position.

! **Risk of crushing injury.**

Keep fingers away from the contact area between the ledge and the cabinet.

! **Risk of cable damage.**

Disconnect any cable from the K1 bottom connector.

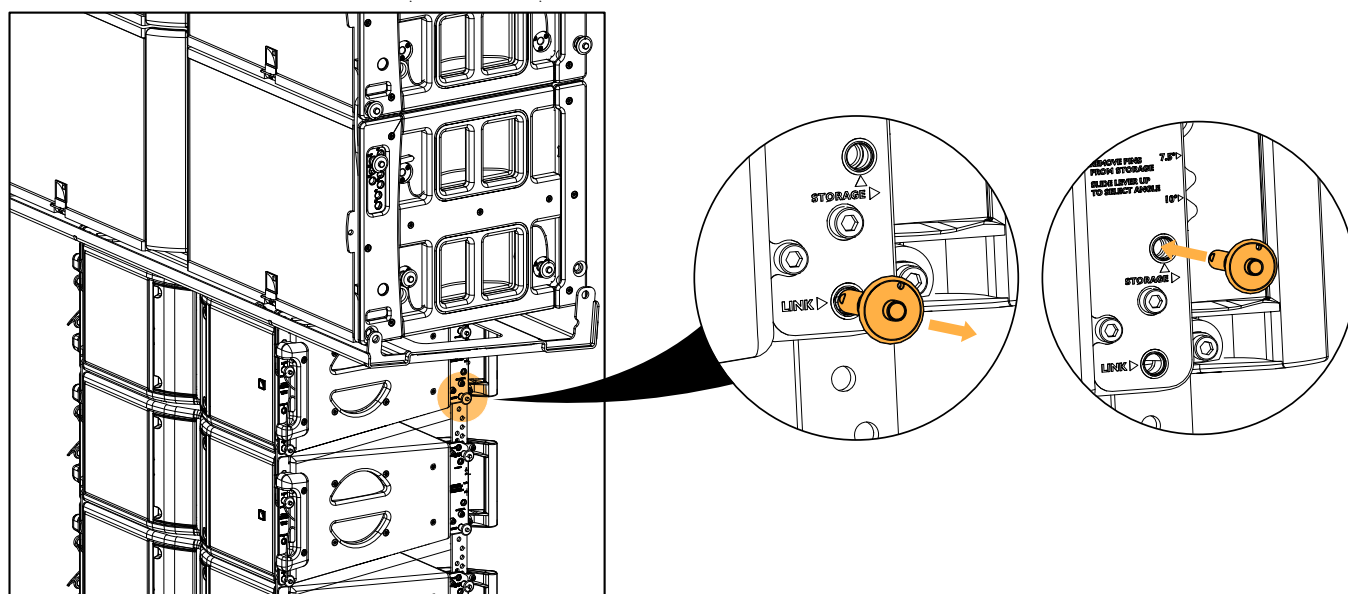

6. Connect KARA-DOWNK1 to the bottom of the K1 array:

- a) Rotate the top Kara II upwards and secure the rear KARA-DOWNK1 tabs to the K1 rigging.

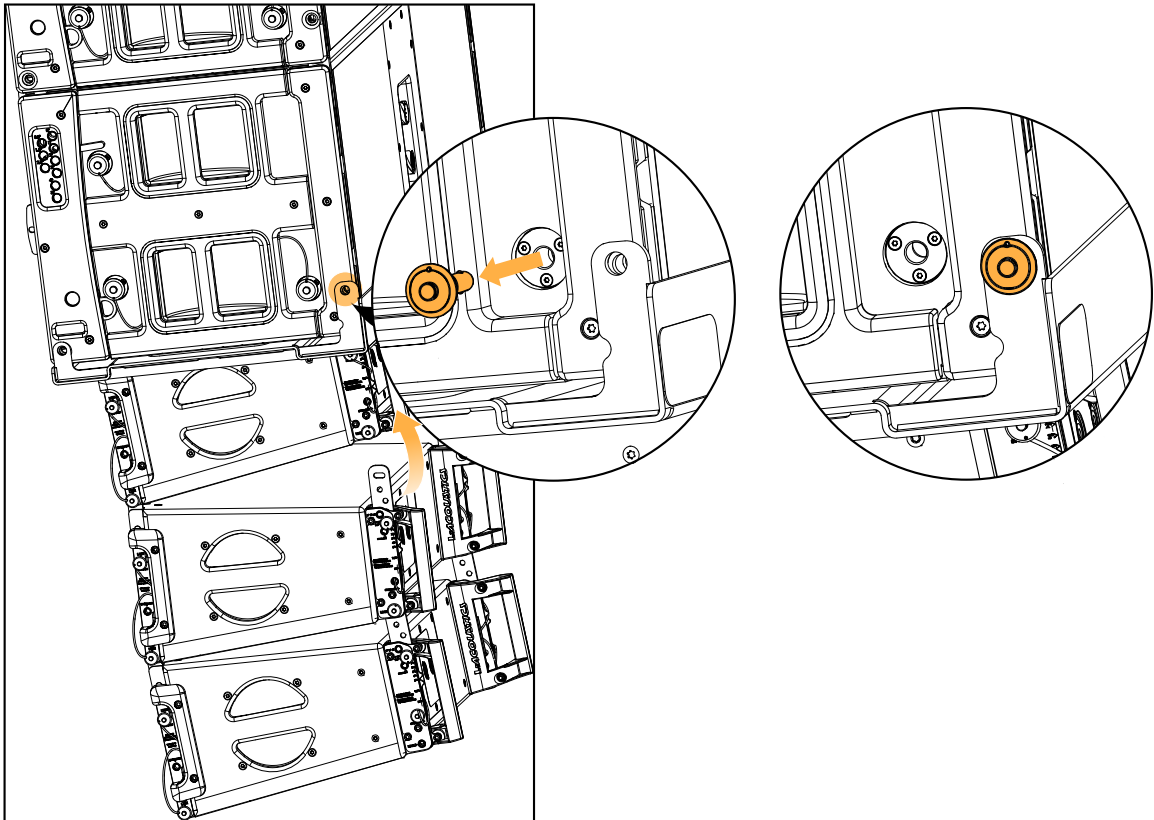

- b) Secure the front KARA-DOWNK1 tabs to the K1 rigging.

If necessary, slightly lower the K1 array.

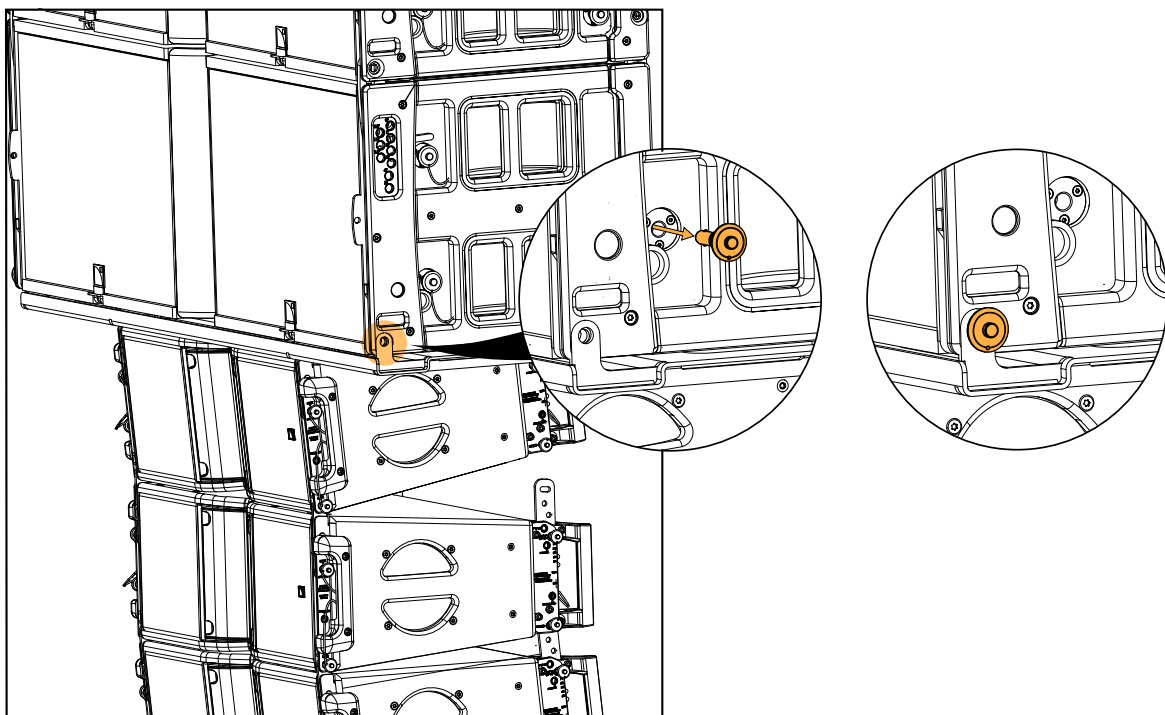

c) Reconnect the top Kara II at the rear to the assembly.

i Use the handles of bottom Kara II.

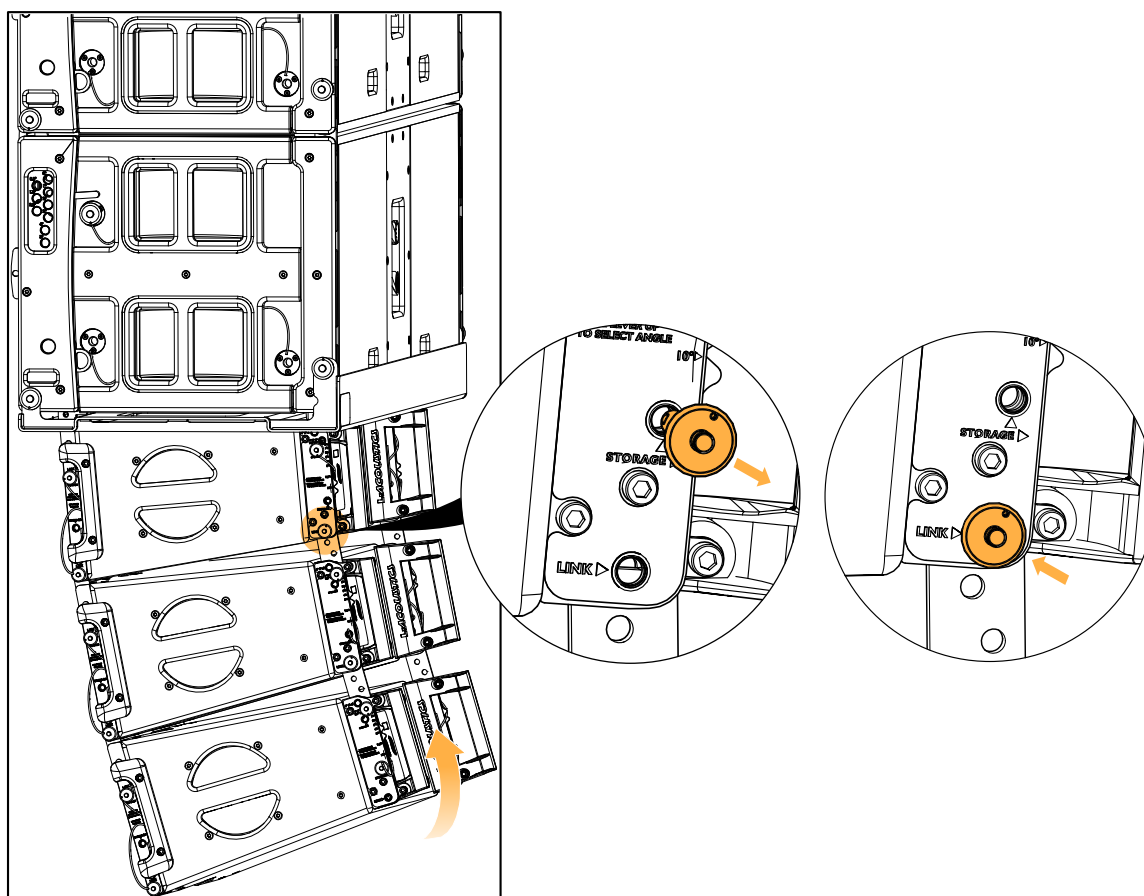

7. Raise the array.
8. Set the inter-enclosure angles.
9. Repeat steps 1 (p.92) to 8 (p.95) the Kara II array is complete.

i Refer to the **Kara II owner's manual**.

Flying a K1 array with K1-BUMP using the CATERPILLAR method

The following procedure describes how to use the CATERPILLAR method to fly a vertical array of K1.

The CATERPILLAR method consists in preparing the array on the ground by adding the enclosures one by one. Each enclosure ships onto a K1-PLA dolly board.

Min number of operators	3
Rigging accessories	4 Ø 22 mm shackles WLL 3.25 t
	K1-BUMP
	K1-PLA

! All along the procedure:

Systematically ensure that each ball-locking pin is fully inserted by pulling on it.

! Secondary safety

Use available holes on the rigging accessories to implement a secondary safety.



For clarity purposes the loudspeaker cabling procedure is not described.

The loudspeaker cables are not represented in the figures.

Use a strain relief to avoid mechanical stress at the connector locations due to cable weight.



Follow the same procedure for K1-SB enclosures.

Prerequisite

- Prepare K1-BUMP. Refer to [Preparing K1-BUMP](#) (p.62).
- If necessary, secure LA-RAK II AVB on K1-BUMP. Refer to [Securing LA-RAK II AVB on K1-BUMP](#) (p.67).

Procedure

1. Line up K1-BUMP and all enclosures with dolly boards at the rigging location.
2. Raise K1-BUMP in front of the first enclosure to more than 0.7 m / 2.3 ft height.

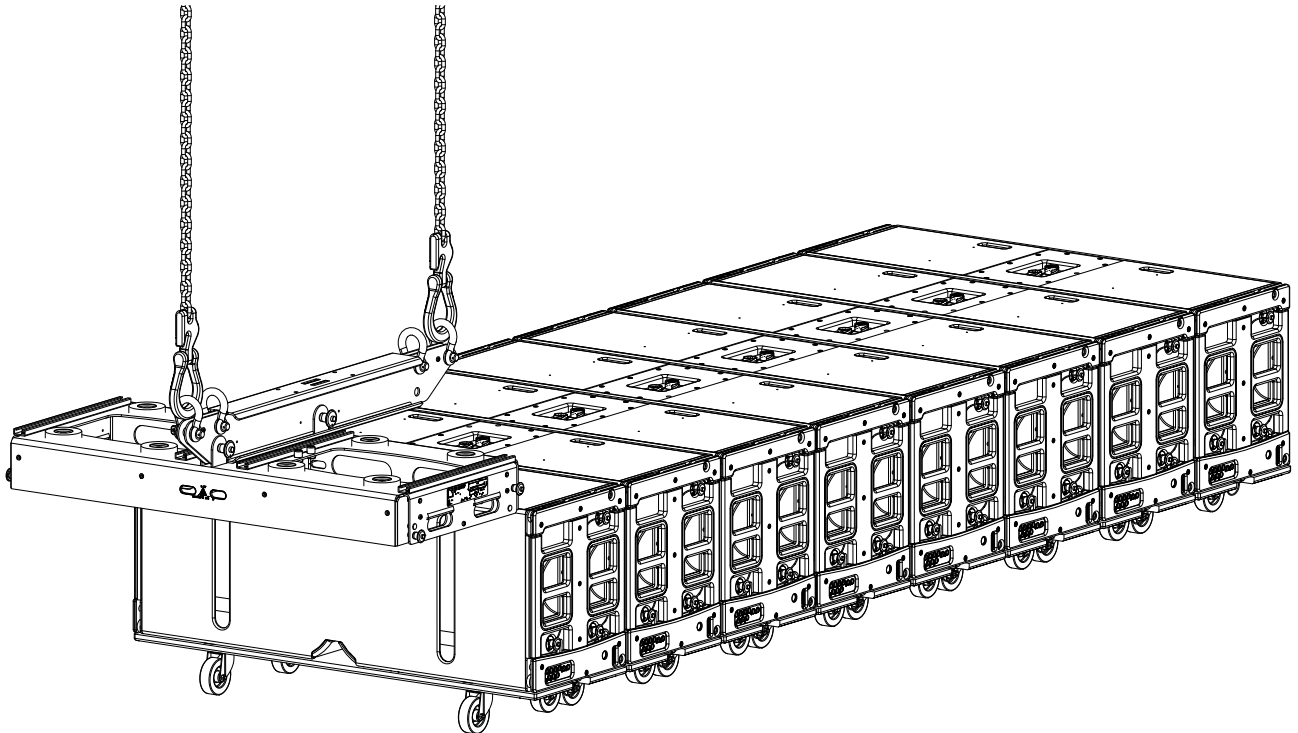

3. On both sides of each enclosure, make sure the automatic locking system button is deactivated. If the button is pressed, pull to disengage the latch.

! When the automatic locking system is deactivated, **a yellow sticker is visible** on the latch.

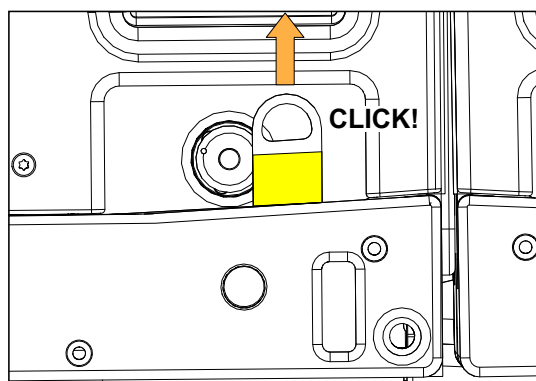

4. On both sides of each enclosure **except for the top one**, lift out the rear rigging arm and secure it to the adjacent enclosure.

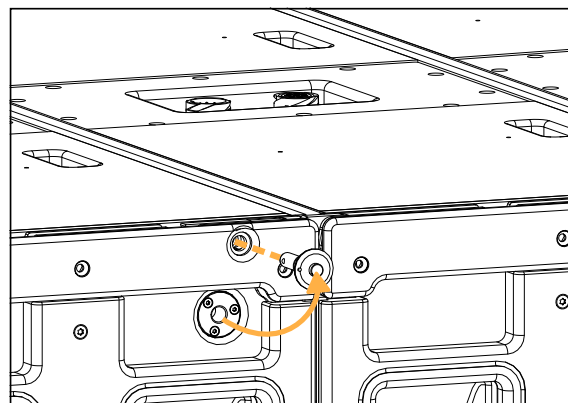
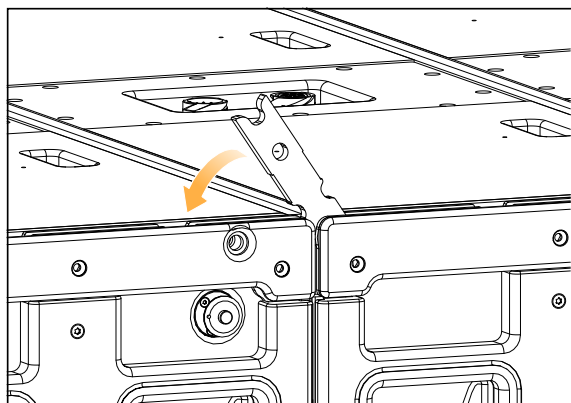

5. On both sides of each enclosure, preset the inter-enclosure angles. Slide out the angle arm to the desired angle hole and insert the ball-locking pin.

i Select the 0° angle for the top enclosure to be aligned with with the K1-BUMP site angle.

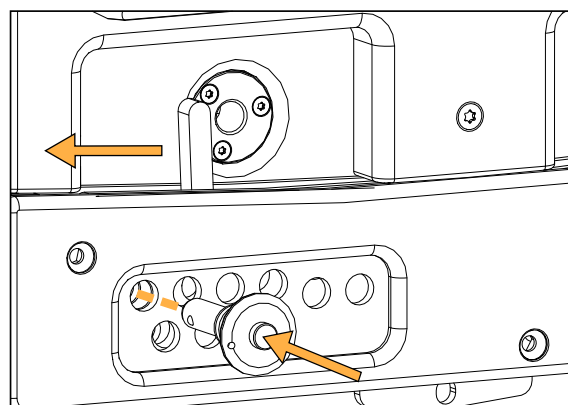
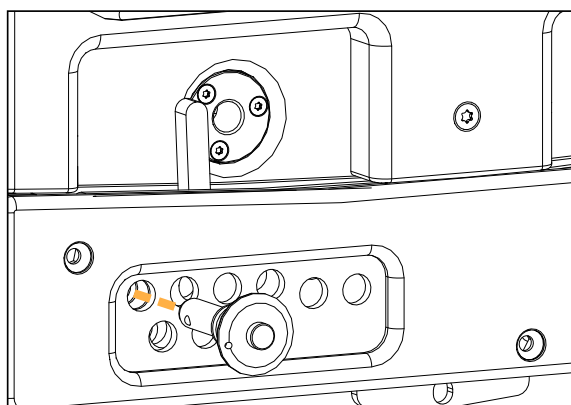

6. On the top enclosure, lift out both rear arms. Secure them to the K1-BUMP rear rigging points using the K1-BUMP ball-locking pins.

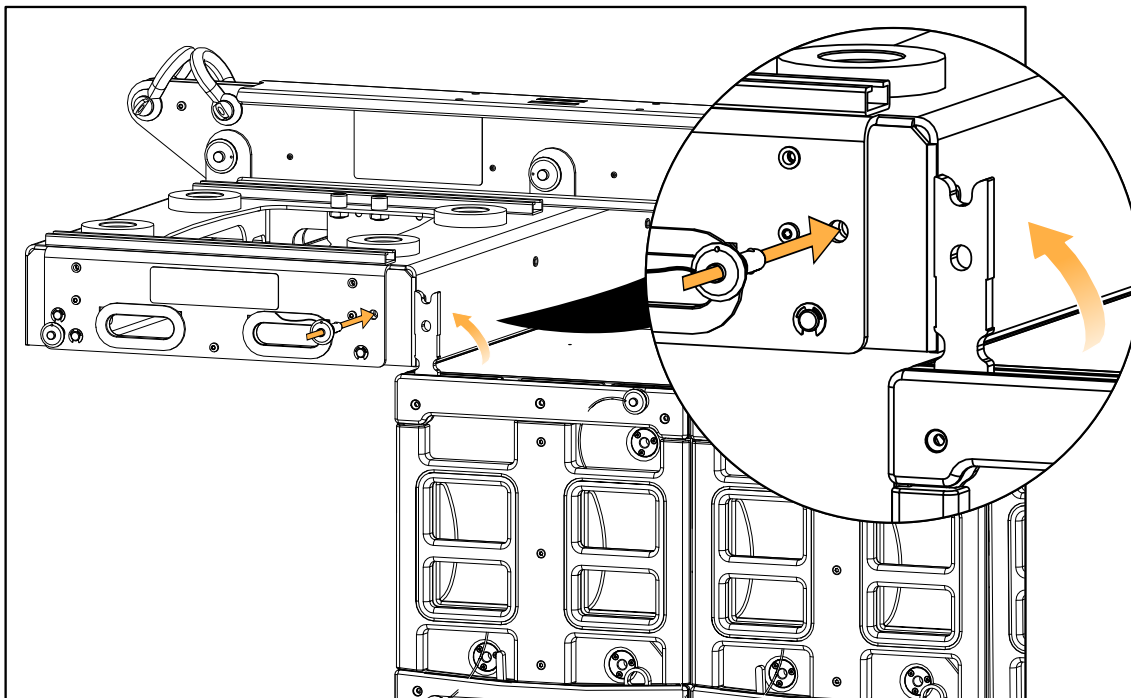

7. On both sides of each K1-PLA, pull on the lanyards to remove the ball-locking pins.

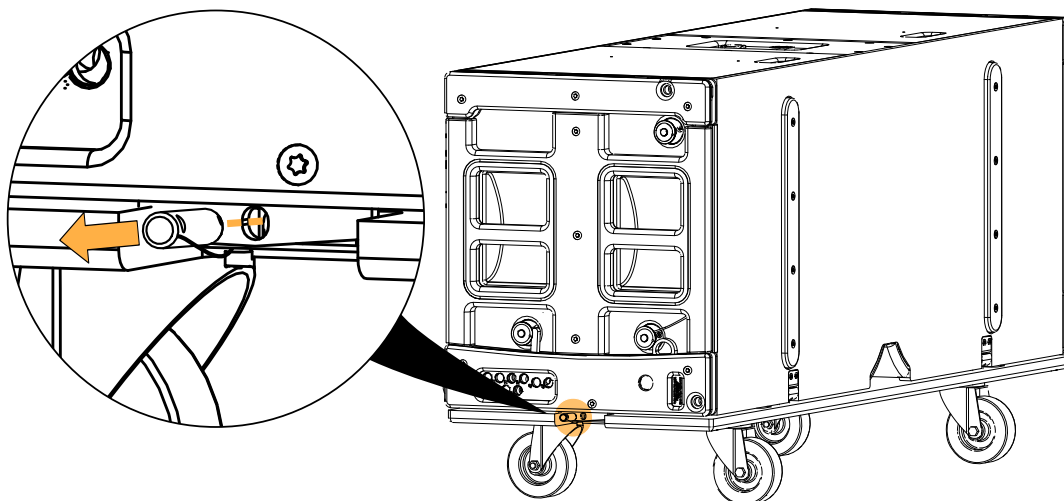

8. Raise the array until the top enclosure is flown and K1-BUMP is in the horizontal position. K1-PLA separates from the top enclosure.

9. Lift the front of the top enclosure and secure the two front rigging arms to K1-BUMP using K1-BUMP ball-locking pins.

! Two people are needed for this operation: one on each side of the enclosure.

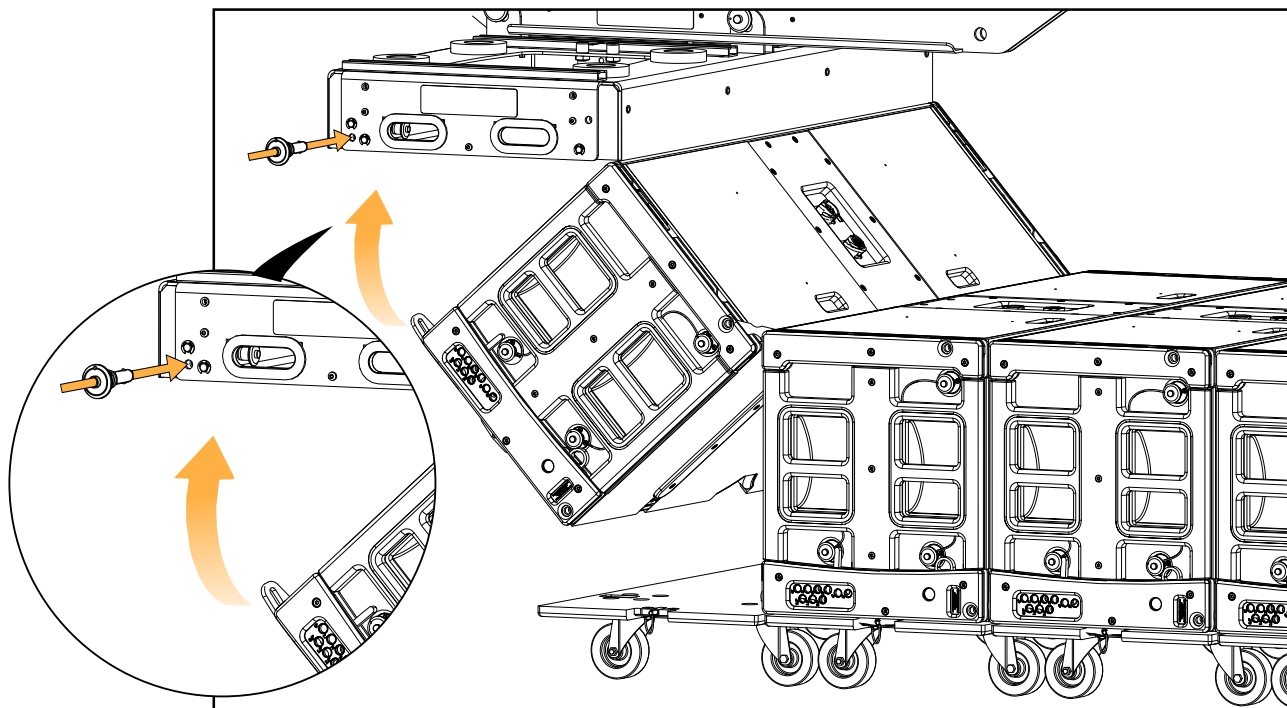

10. Raise the array until the second enclosure is flown.

! Have one person holding the last enclosure to prevent array rough movements.

11. Lift the front of the second enclosure and secure both front rigging arms to the top enclosure.

! Two people are needed for this operation: one on each side of the enclosure.

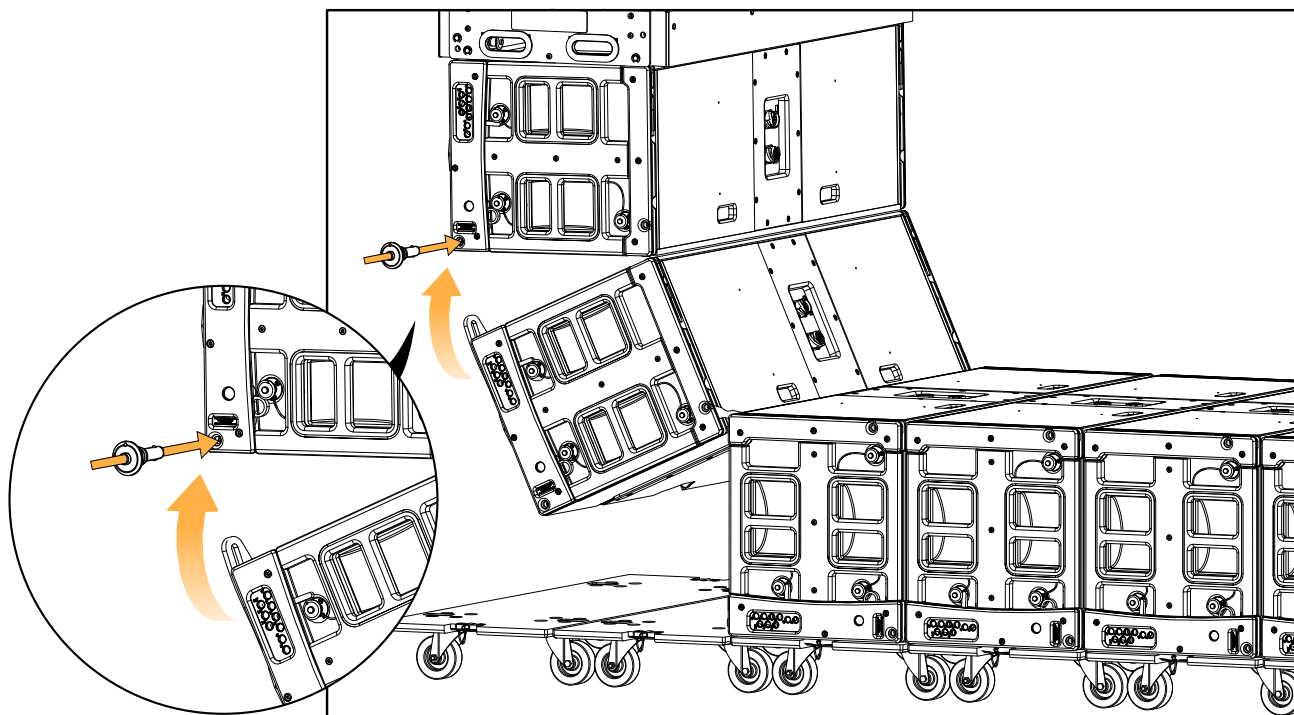

- 12.** On each side of the top enclosure, press the angle locking button to lock the inter-enclosure angle. The latch slightly retracts when the button is pushed (yellow label visible).

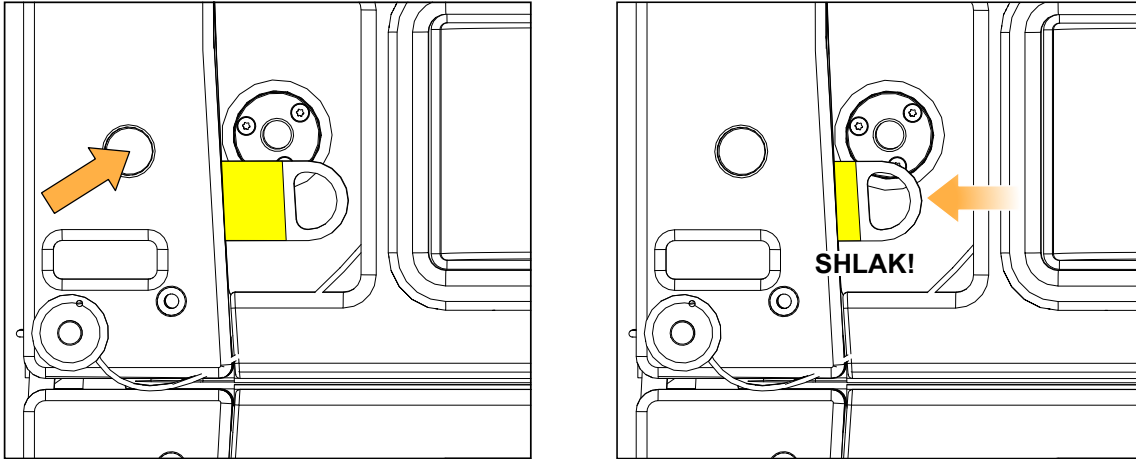

- 13.** Repeat steps 10 (p.99) to 12 (p.100) until all enclosures composing the array are flown.



- Check that all ball-locking pins are **fully inserted** in rigging position.
Check that all rear rigging arms are secured by making sure **no yellow sticker is visible**.

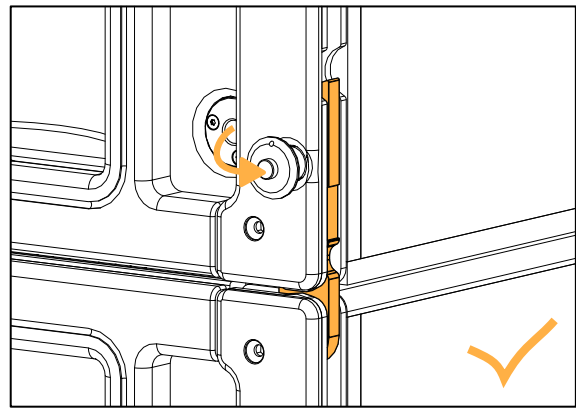
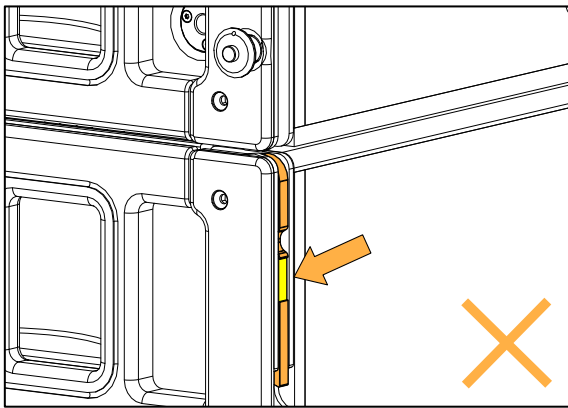

- 14.** Fly the array at desired trim height and adjust the site and azimuth angles.



- Always check that the automatic locking system is activated (except on the bottom enclosure). When the automatic locking system is activated, **no yellow stickers is visible** on the latches.

What to do next

Add a Kara II downfill array. Refer to [Rigging a Kara II downfill array under a K1 array with KARA-DOWNK1](#) (p.92).

Removing a K1 array using the CATERPILLAR method

The following procedure describes how to use the CATERPILLAR method to remove an array of K1/K1-SB.

The CATERPILLAR disassembly method consists in landing each enclosure on a K1-PLA dolly board for individual shipping.

Min number of operators	3
Rigging accessories	K1-PLA

! **All along the procedure:**
Systematically ensure that each ball-locking pin is fully inserted by pulling on it.

Prerequisite

To remove K2 or Kara II downfill arrays, refer to the **K2** or **Kara II owner's manual**.

Procedure

1. Lower the array at 0.3 m / 1 ft height.
2. Secure a K1-PLA to the **four bottom enclosures** of the array.
Insert both K1-PLA ball-locking pins on each K1-PLA.

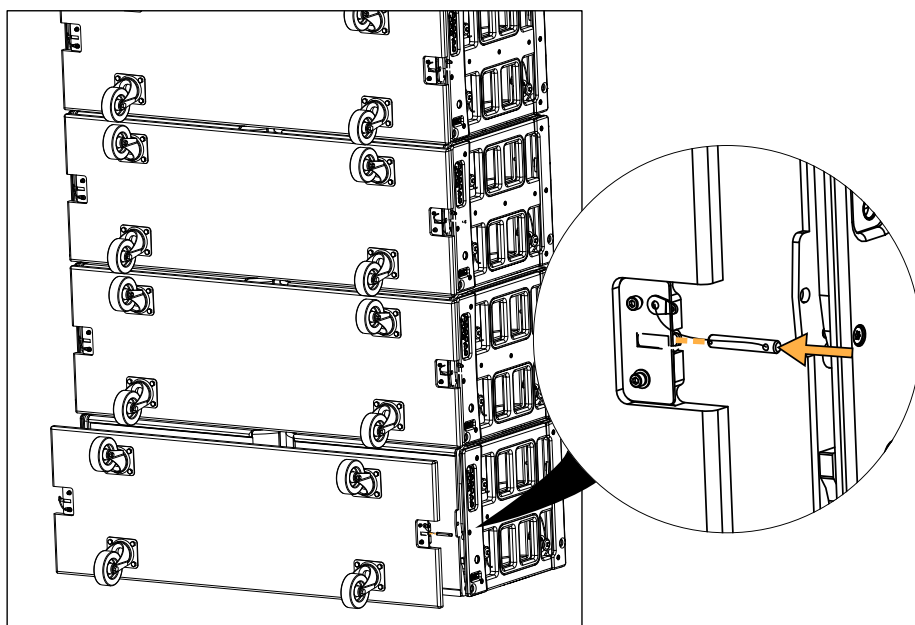

3. On each side of the four enclosures, pull the latch until a click is heard.

! **A yellow sticker must be visible** on each latch.

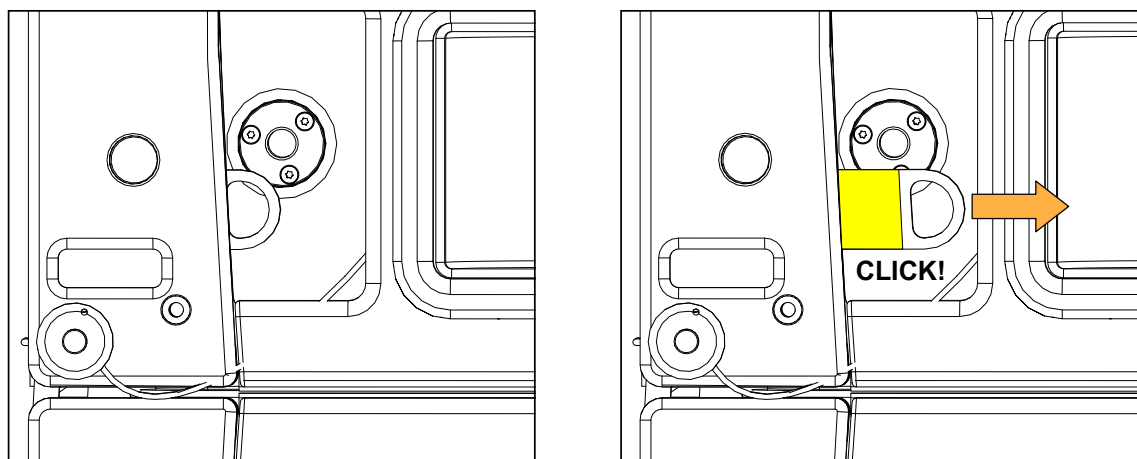

4. Land the four enclosures:

a) Firmly hold the bottom enclosure by its handles.



Two people are needed for this operation: one on each side of the enclosure.

Use the ergonomic handles to lift the enclosure.

b) Remove the two ball-locking pins securing the bottom enclosure at the front. Put them in their storage locations.



The rear rigging points must remain attached to prevent the bottom enclosure from falling.

c) Pull back the bottom enclosure while lowering the array until the four K1-PLA wheels touch the ground.



Two people are needed for this operation: one on each side of the enclosure.

Use the ergonomic handles to pull back the enclosure.

d) Repeat step 4 (p.102) until the four enclosures are on the ground, attached by the rear rigging arms.

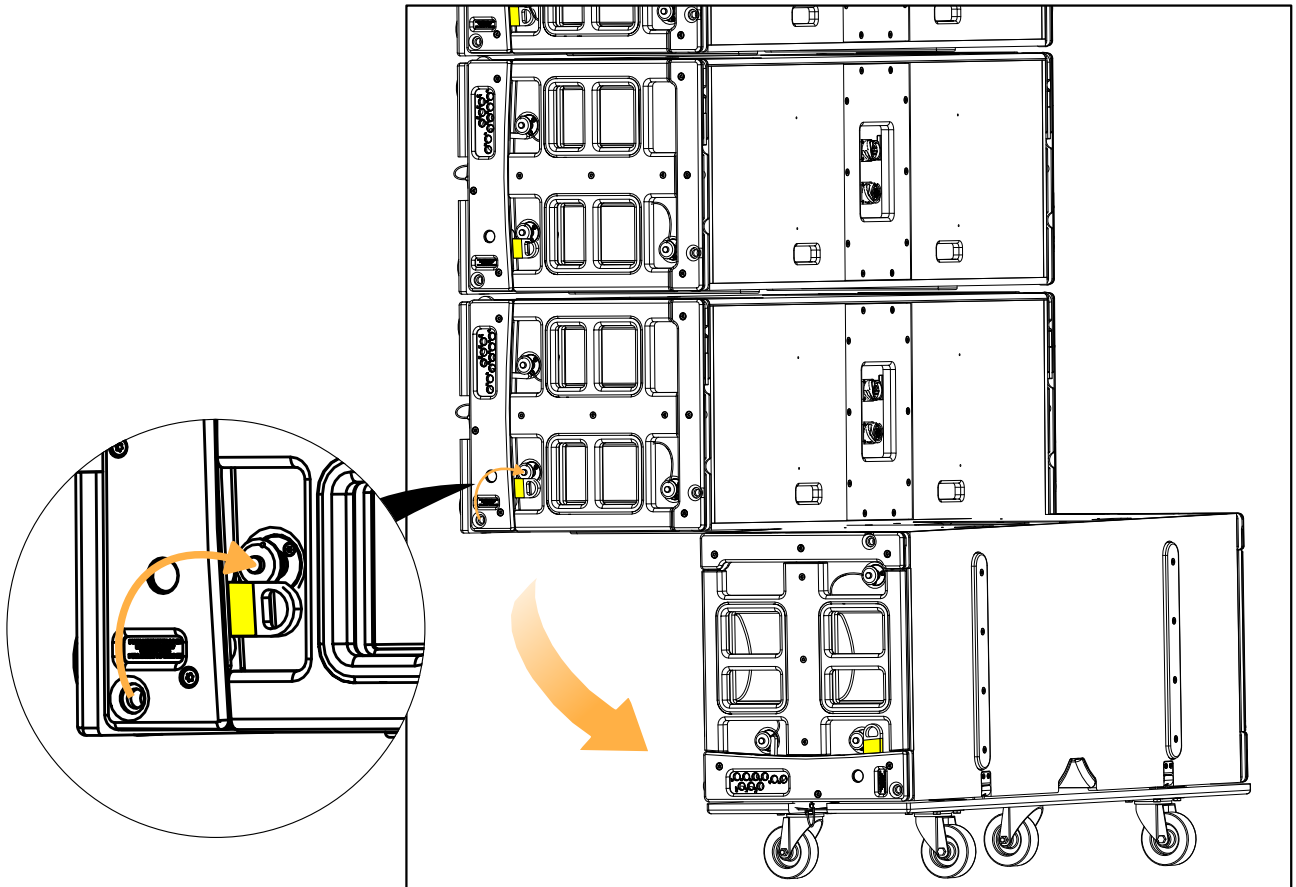

5. On both sides of the four landed enclosures:

a) Remove the angle setting ball-locking pins. Put them in their storage locations.

b) Slide in the front rigging arm.

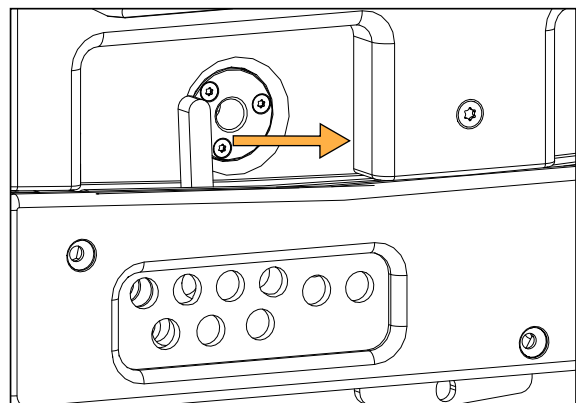
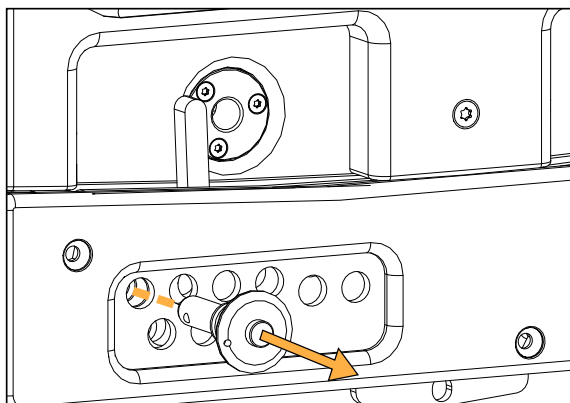

6. If necessary, repeat steps 1 (p.101) to 7 (p.102) until all enclosures composing the array are on the ground.

- 7.** On the K1-BUMP, remove the two rear ball-locking pins.
Pull back the two rear rigging arms of the top enclosure into their storage locations.

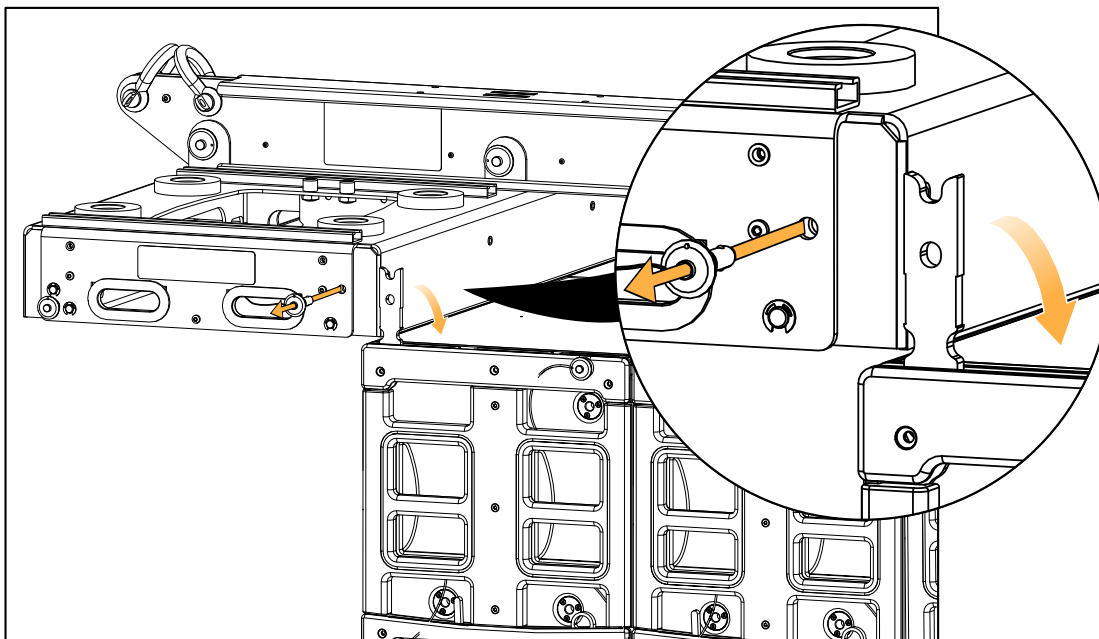

- 8.** On all other enclosures, remove the rear ball-locking pins. Pull back the rear rigging arms into their storage locations.

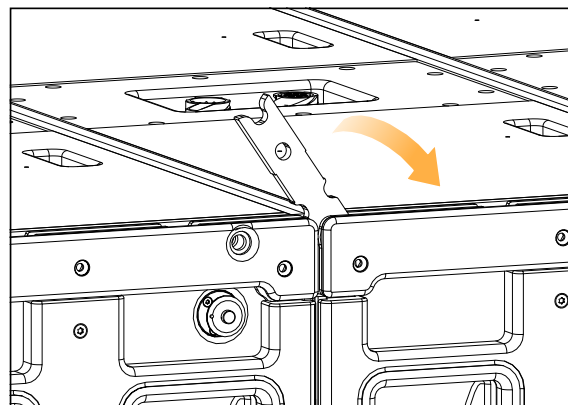
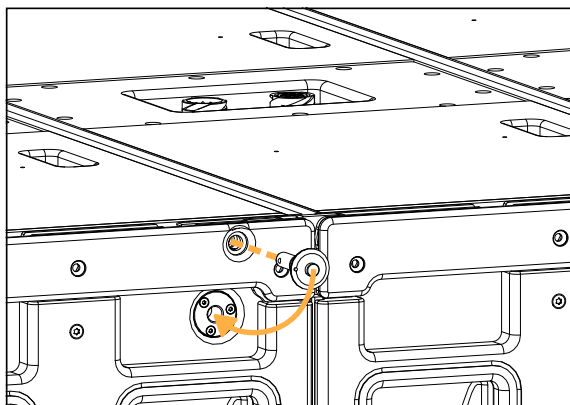

- 9.** If necessary, lower K1-BUMP until it touches the ground and remove the LA-RAK II AVB touring racks.
10. Place K1-BUMP in K-BUMPFLIGHT using the motor.

Connection to LA amplified controllers

! Refer to the **Amplification reference** technical bulletin for the latest information on compatibility with amplified controllers and cabling schemes for all enclosure types.

Enclosure drive capacity per amplified controller

Make sure the total number of connected enclosures does not exceed the maximum number of enclosures per controller (refer to the footnotes).

	LA12X
	per output* / total
K1	2 / 2
K1-SB	1 / 4
K2	3 / 3
Kara II	3 / 6

Cabling scheme for K1 or K2

Refer to the cabling schemes to connect the enclosures to different types of output configurations.

Four-channel CA-COM output

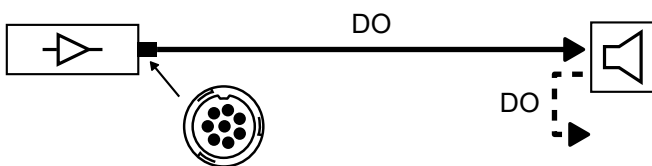

Cabling schemes for K1-SB

Two-channel speakON output

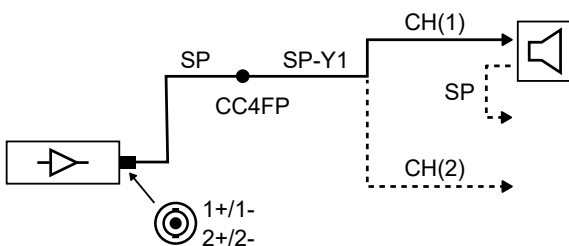

Four-channel CA-COM output

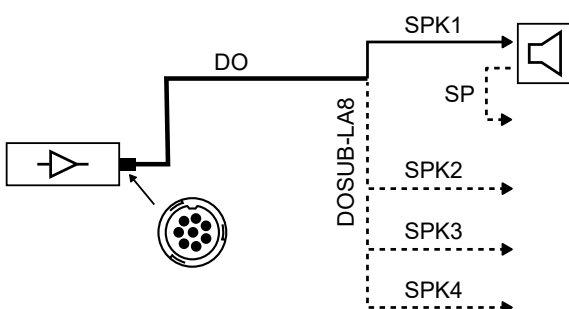

* For passive loudspeakers, the value corresponds to the number of enclosures in parallel on the output. For active loudspeakers, the value corresponds to the number of sections in parallel on the output.

Cabling scheme for Kara II

Four-channel CA-COM output

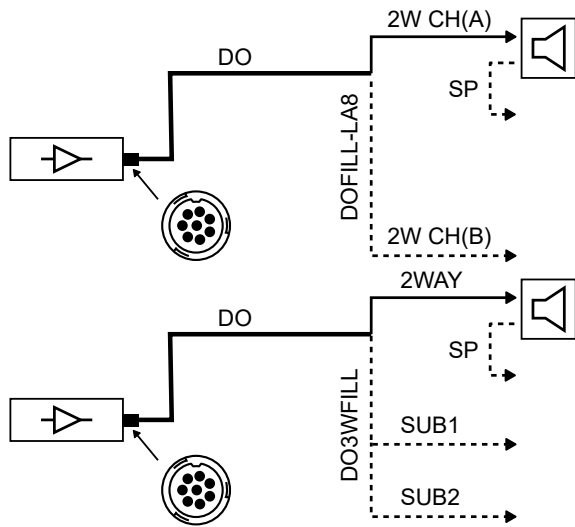

Two-channel speakON output

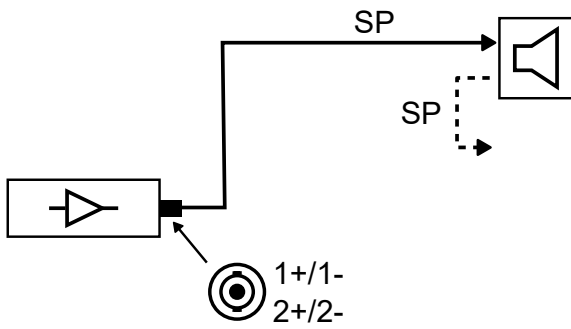

Corrective maintenance

Tools and consumables

Before performing maintenance on this product, make sure all the tools listed are available. References are given for FACOM® products in this table. Other manufacturers can be used.

name	reference	distributor
set of 6-point 1/4" sockets *	RL.NANO1 / R.360NANO	-
electric screwdriver with torque selector	-	-
Long nosed pliers	-	-
Electrical soldering material	-	-
combination pliers *	-	-
blue threadlocker	-	-



* included in the L-Acoustics Maintenance Toolcase.

Maintenance Toolcase

The Maintenance Toolcase is a carry-on suitcase that includes all the tools required to perform maintenance on L-Acoustics products. This toolcase is aimed at Certified Providers.

The Maintenance Toolcase uses a Peli™ 1510 Protector case that features three pre-cut layers of foam to safely fit the tools. The Maintenance Toolcase includes tools manufactured by FACOM®, Fluke®, Tohnichi, ABUS, and Würth.



All third-party trademarks, registered trademarks, or product names are the property of their respective owners.

K1

Introduction

This section contains the following maintenance procedures:

- [D/R - Grill](#) (p.109)
- [D/R - LF speaker](#) (p.110)
- [D/R - Fins](#) (p.111)
- [D/R - MF speaker](#) (p.112)
- [D/R - Connector plate](#) (p.113)
- [D/R - HF driver](#) (p.114)
- [D/R - HF diaphragm](#) (p.115)

For advanced maintenance, contact your L-Acoustics representative.

K1 Exploded views

In order to operate, follow the order outlined here. Each assembly refers to the corresponding Disassembly/Reassembly (D/R) procedure and the necessary repair kit (KR).



Using the KR HSPH154 reconing kit

Follow the instructions to remove the LF speaker from the enclosure.

Perform the reconing procedure according to the information provided by the manufacturer.

Use the screws and fasteners provided in KR HSPH154 for reassembly.

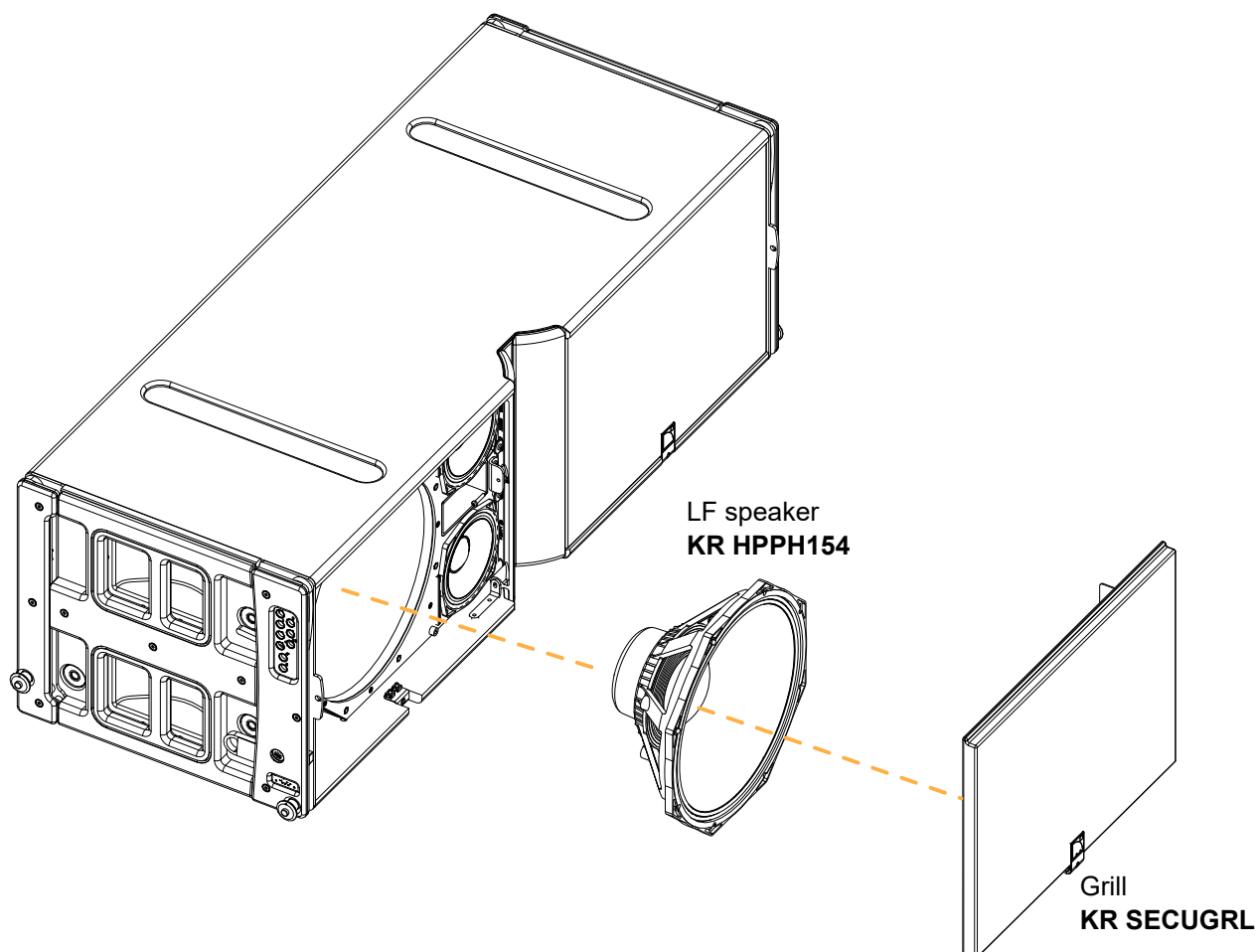

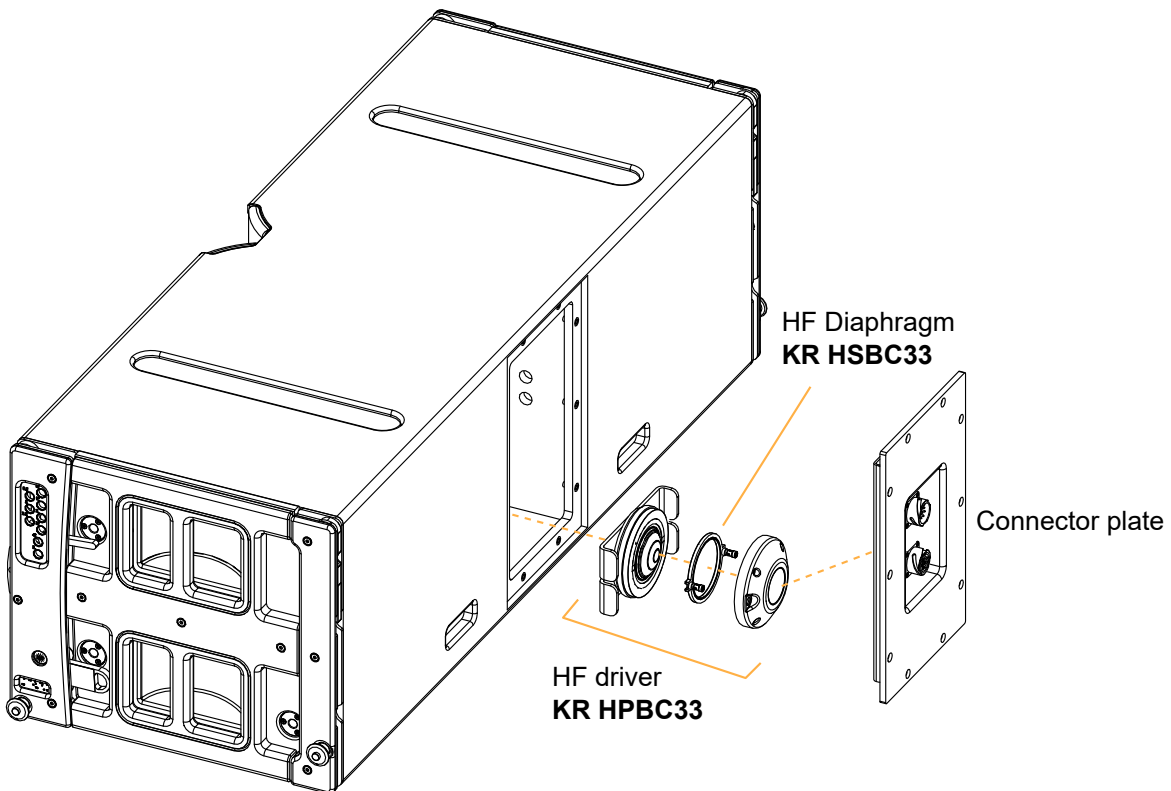
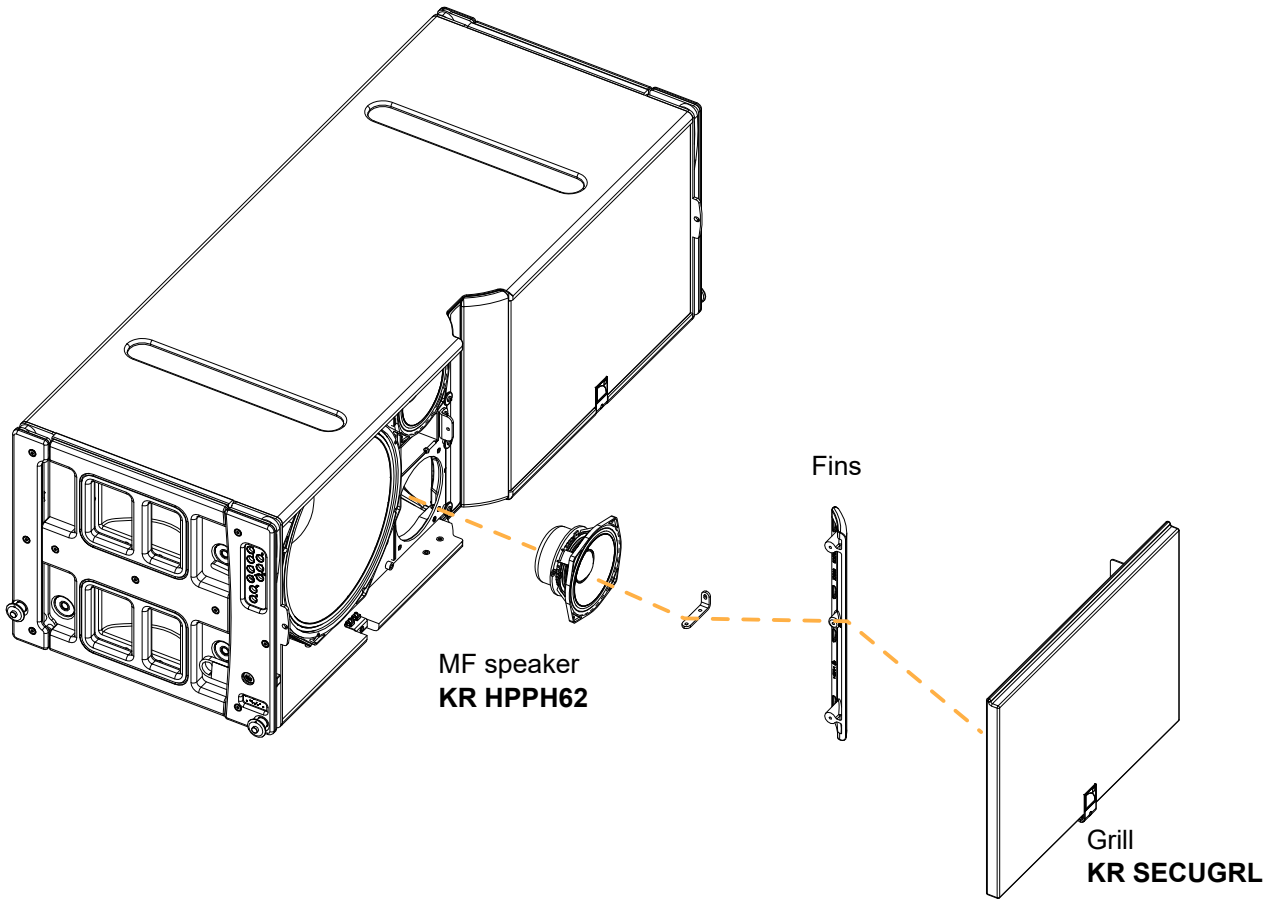

Disassembly and Reassembly procedures

D/R - Grill

Tools

- torque screwdriver
- 4 mm hex bit
- grill safety tool (provided)
- flat tool

Consumables

- blue threadlocker

Repair kit

KR HPPH154* - Kit HP PH154 Speaker 15" - 8 ohms

or KR HPPH62 - Kit HP PH62 Speaker 6.5" - 8 ohms

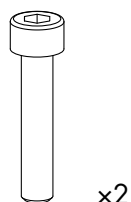

x2

S100155

M5x25 hex



x2

S158

plain washer Ø 5 mm

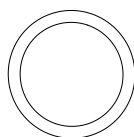

x100

100557

grill safety O-ring

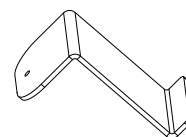

x1

100226

grill safety tool



*The screws and fasteners are also provided in the KR HSPH154 (Kit reconing 15").

Prerequisite

The enclosure is placed on its top.

Exploded view



For safety reasons, always use the new screws and spare parts provided in the KR.
If no new screws are available, use blue threadlocker.

Use a flat tool to pull the O-ring over the logo.

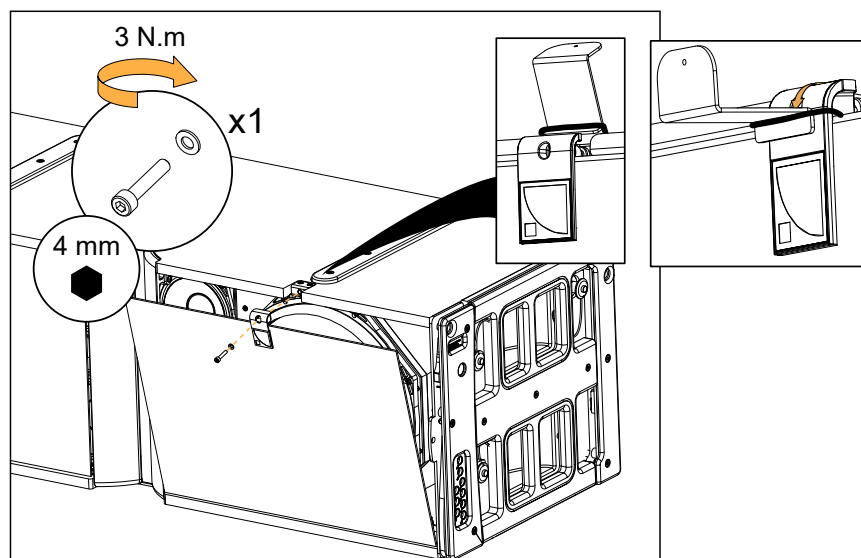

D/R - LF speaker

Tools

- torque screwdriver
- 5 mm hex bit

Repair kit

KR HPPH154*

Kit HP PH154 Speaker 15" - 8 ohms

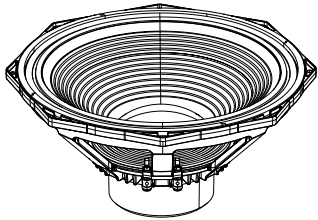

x1

18463

15" speaker - 8 ohms



x8

S100054

M6x30 hex



*The screws and fasteners are also provided in the KR HSPH154 (Kit reconing 15").

Prerequisite

Grill removed.

See [D/R - Grill](#) (p.109).

Exploded view



For safety reasons, always use the new screws and spare parts provided in the KR. If no new screws are available, use blue threadlocker.



Gradually tighten the screws following a star pattern.

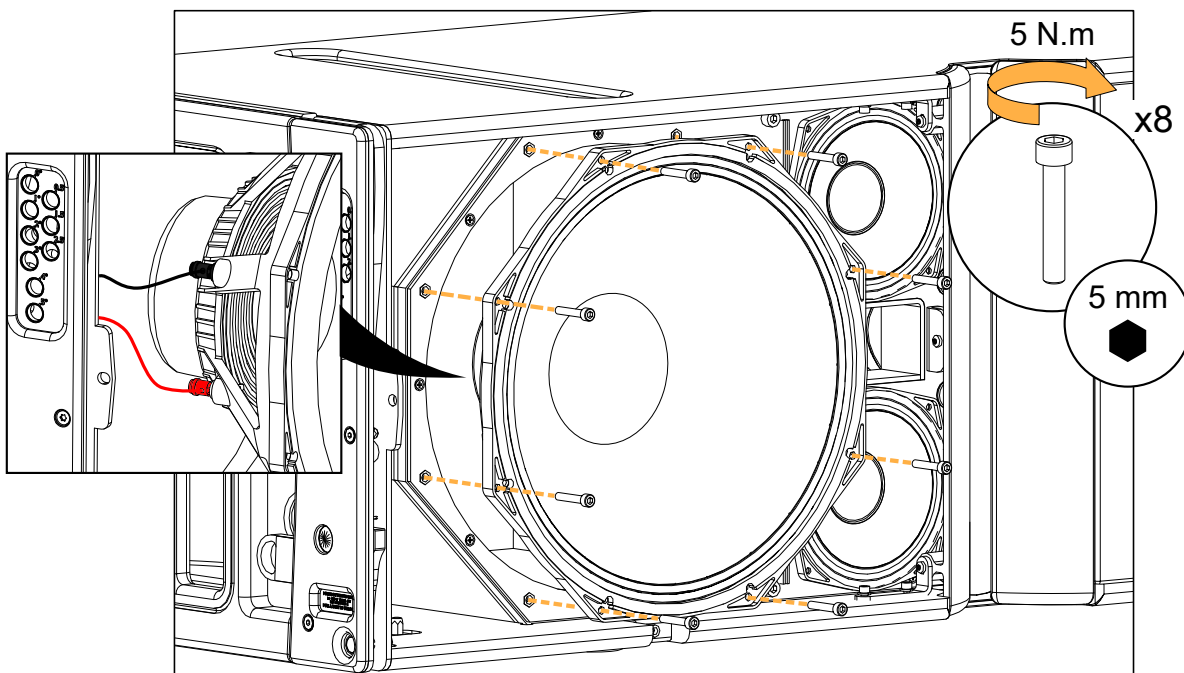

What to do next

Perform the [Acoustical check](#) (p.58) procedures.

D/R - Fins

Tools

- torque screwdriver
- T20 Torx bit

KR HPPH62

Kit HP PH62 Speaker 6.5" - 8 ohms

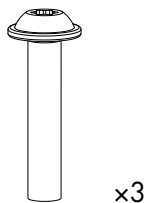

S237

M5x16 hex

Prerequisite

Grill removed.

See [D/R - Grill](#) (p.109).

Exploded view

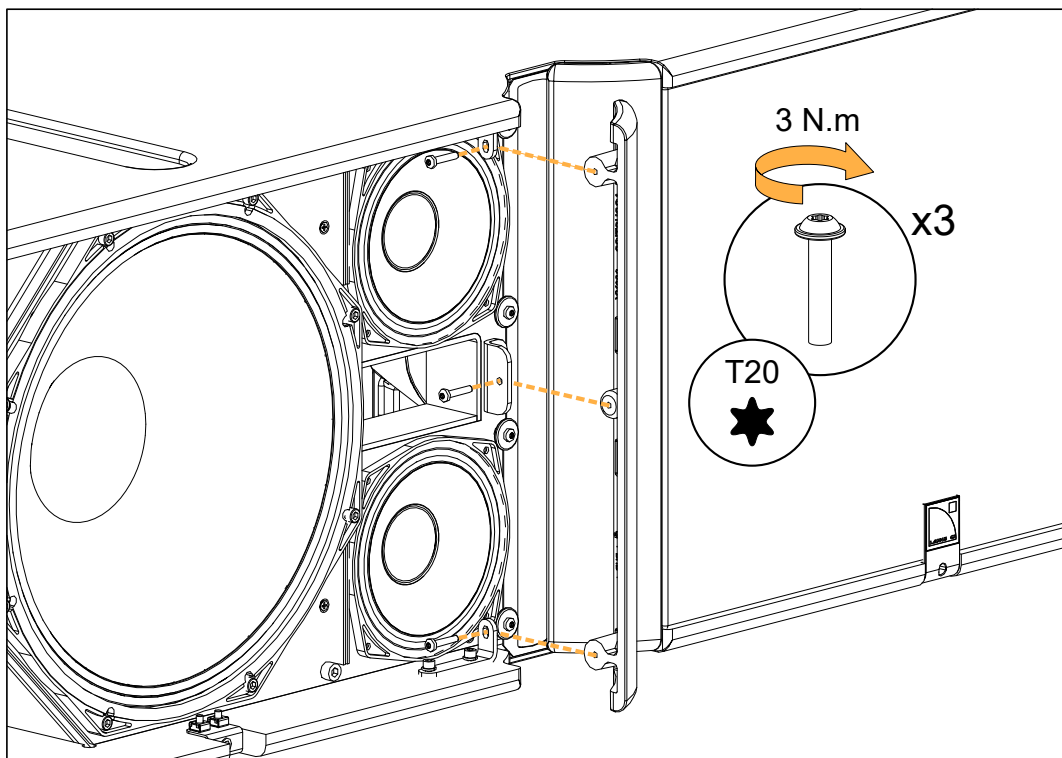

D/R - MF speaker

Tools

- torque screwdriver
- 4 mm hex bit

Repair kit

KR HPPH62

Kit HP PH62 Speaker 6.5" - 8 ohms

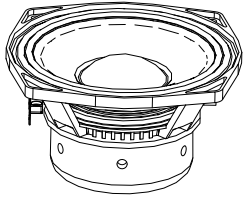

x1

18614

6.5" LF/MF speaker - 8 Ω



x4

S342

M5x20 hex



x2

S100113

M5x16 hex

Prerequisite

Grill removed.

See [D/R - Grill](#) (p.109).

Fin removed.

See [D/R - Fins](#) (p.111).

Exploded view



For safety reasons, always use the new screws and spare parts provided in the KR.



Gradually tighten the screws following a star pattern.

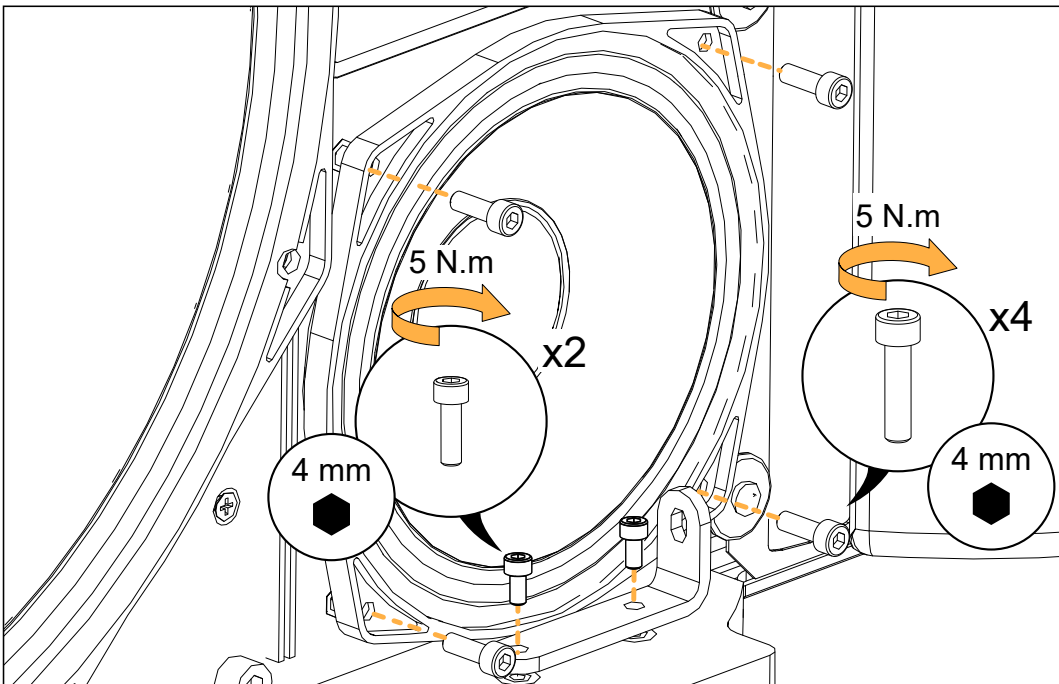

What to do next

Perform the [Acoustical check](#) (p.58) procedures.

D/R - Connector plate

Tools

- torque screwdriver
- T30 Torx bit

Repair kit

KR HPBC33 - Kit HP BC33 Driver 3" - 20 ohms

or KR HSBC33 - Kit diaphragm for 3" driver



x1

100585_2

adhesive gasket kit

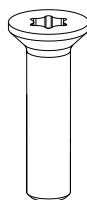

x10

S100110

M6x25 Torx

Exploded view



For safety reasons, always use the new screws and spare parts provided in the KR.
If no new screws are available, use blue threadlocker.



If the gasket is damaged, remove and replace it.

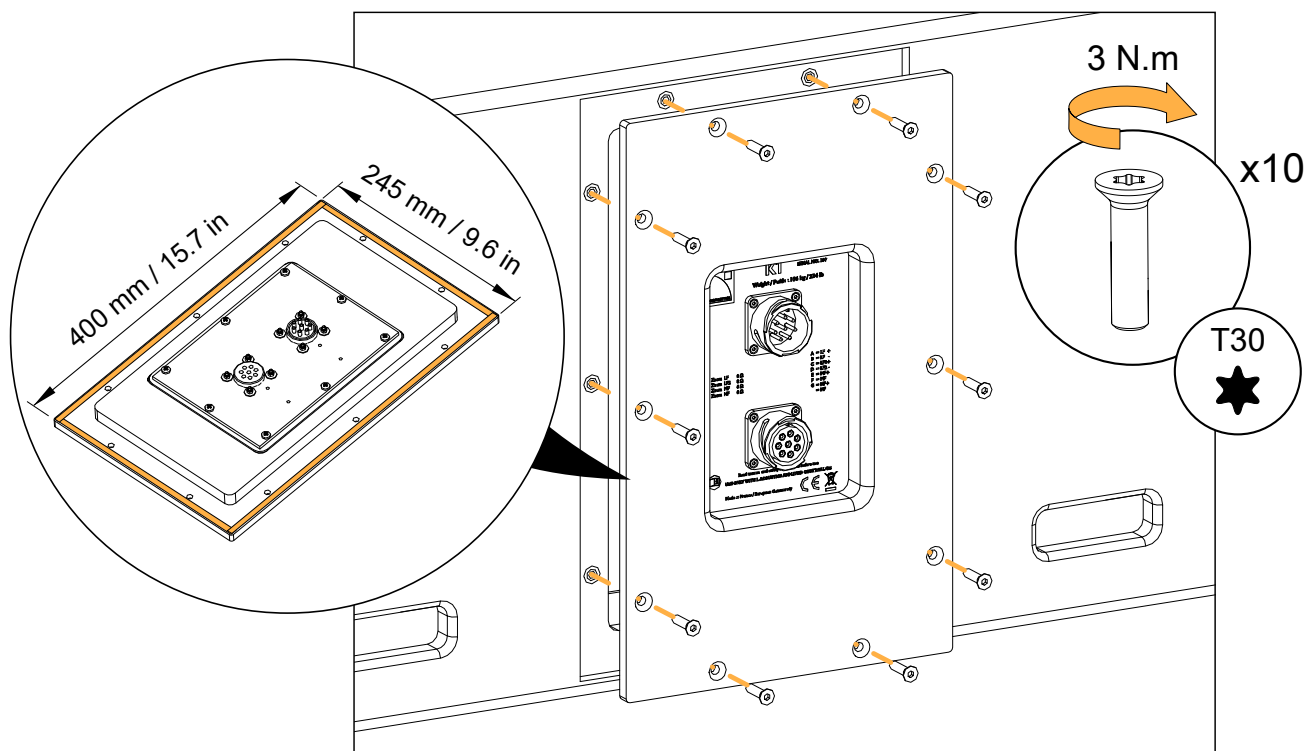

D/R - HF driver

Tools

- torque screwdriver
- 5 mm hex bit

Repair kit

KR HPBC33

Kit HP BC33 Driver 3" - 20 ohms

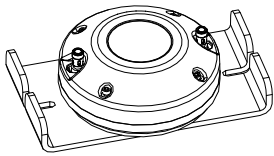

x1

G223

3" HF driver - 20 ohms assembly



x1

100585_2

adhesive gasket kit



x6

S100036

M6x25 hex

i * The gasket and the screws are also provided in the KR HSBC33 (Kit diaphragm for 3" driver).

Prerequisite

Connector plate removed.

See [D/R - Connector plate](#) (p.113).

Exploded view

! For safety reasons, always use the new screws and spare parts provided in the KR.
If no new screws are available, use blue threadlocker.

i If the gasket is damaged, remove and replace it.

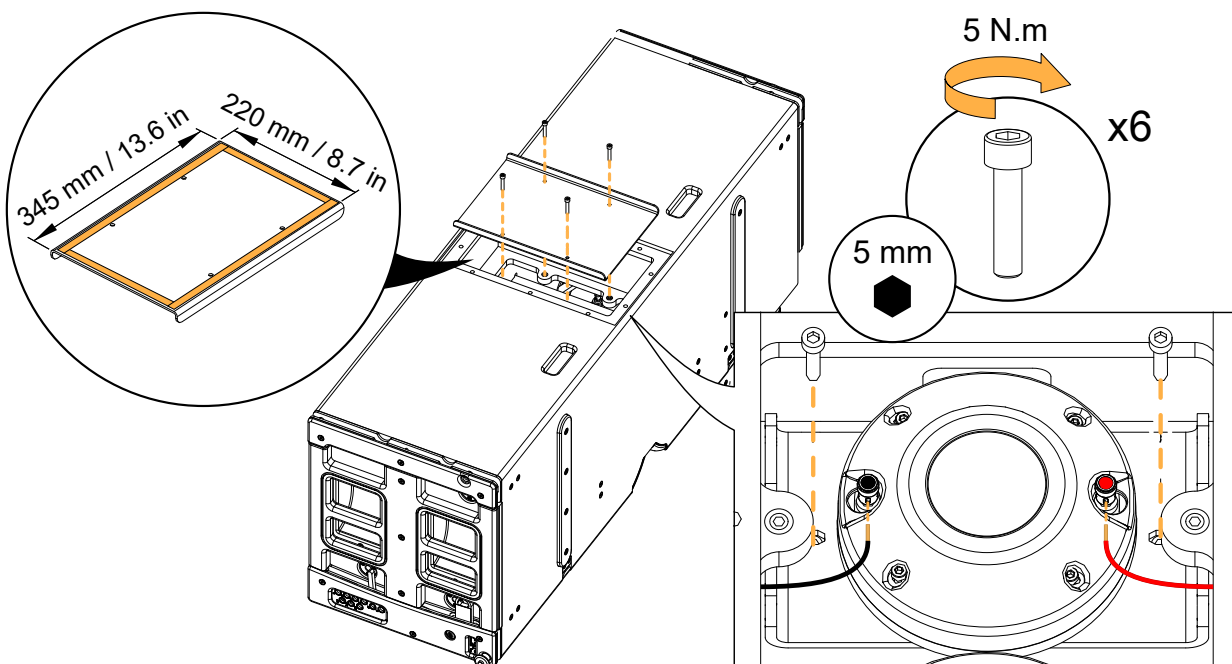

What to do next

Perform the [Acoustical check](#) (p.58) procedures.

D/R - HF diaphragm

Tools

- torque screwdriver
- 3 mm hex bit
- 3 mm hex wrench
- compressed air blower

Consumables

- double face adhesive tape

Repair kit

KR HSBC33

Kit diaphragm for 3" driver

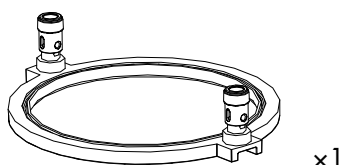

03024

diaphragm for 1.4" driver - 20 ohms (with shims)

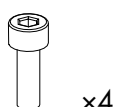

S03024

M4x14 hex

Prerequisite

Connector plate removed.

HF driver removed.

See [D/R - Connector plate](#) (p.113).

See [D/R - HF driver](#) (p.114)

Exploded view



Use a blower or double face adhesive tape to clean the dome and the air gap.

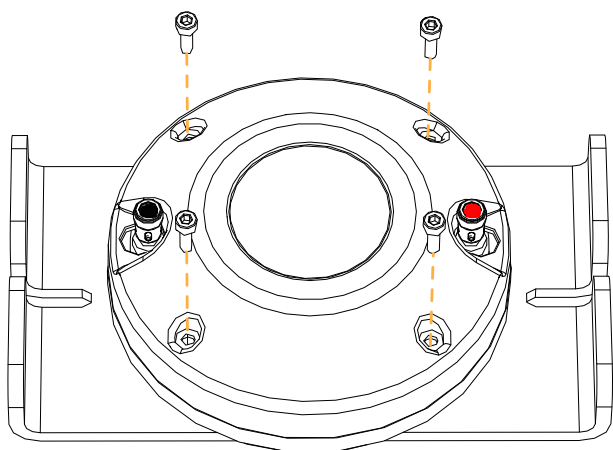

K1-SB

Introduction

This section contains the following maintenance procedures:

- [D/R - Grill](#) (p.117)
- [D/R - LF speaker](#) (p.118)

For advanced maintenance, contact your L-Acoustics representative.

Exploded views

In order to operate, follow the order outlined here. Each assembly refers to the corresponding Disassembly/Reassembly (D/R) procedure and the necessary repair kit (KR).

Using the KR HSPH154 reconing kit

Follow the instructions to remove the LF speaker from the enclosure.

Perform the reconing procedure according to the information provided by the manufacturer.

Use the screws and fasteners provided in KR HSPH154 for reassembly.

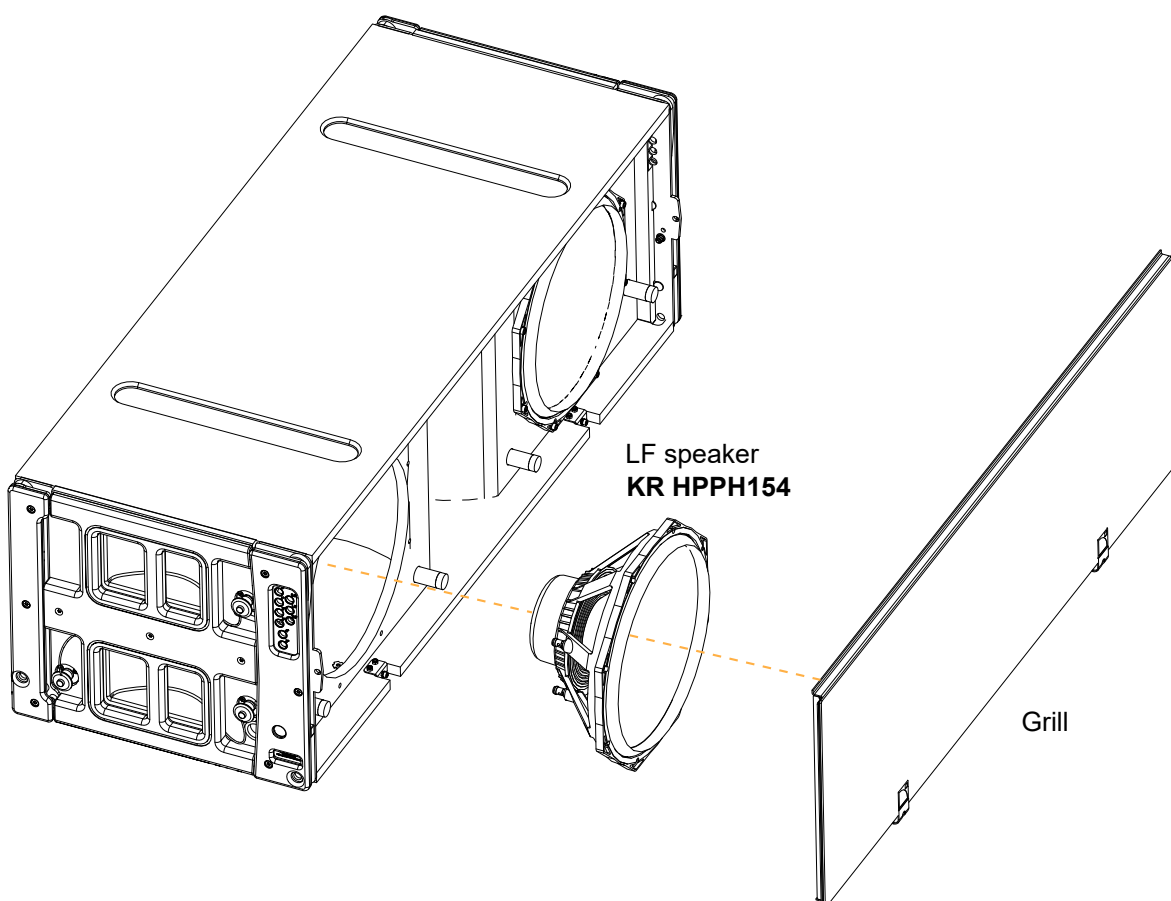

Disassembly and Reassembly procedures

D/R - Grill

Tools

- torque screwdriver
- 4 mm hex bit

Repair kit

KR HPPH154*

Kit HP PH154 Speaker 15" - 8 ohms

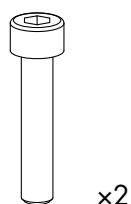

S100155

M5x25 hex



S158

plain washer Ø 5 mm



*The screws and fasteners are also provided in the KR HSPH154 (Kit reconing 15").

Prerequisite

The enclosure is placed on its top.

Exploded view



For safety reasons, always use the new screws and spare parts provided in the KR.
If no new screws are available, use blue threadlocker.

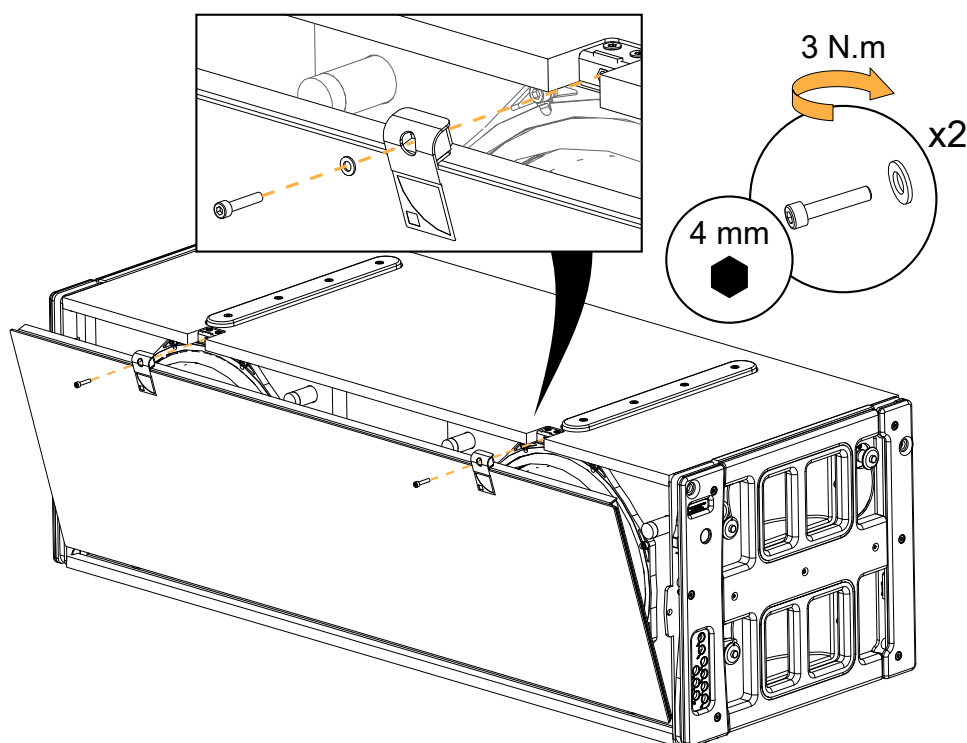

D/R - LF speaker

Tools

- torque screwdriver
- 5 mm hex bit

Repair kit

KR HPPH154*

Kit HP PH154 Speaker 15" - 8 ohms

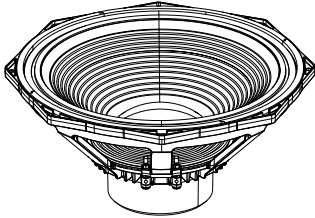

x1

18463

15" speaker - 8 ohms



x8

S100054

M6x30 hex



*The screws and fasteners are also provided in the KR HSPH154 (Kit reconing 15").

Prerequisite

Grill removed.

See [D/R - Grill](#) (p.117).

Exploded view



For safety reasons, always use the new screws and spare parts provided in the KR. If no new screws are available, use blue threadlocker.



Gradually tighten the screws following a star pattern.

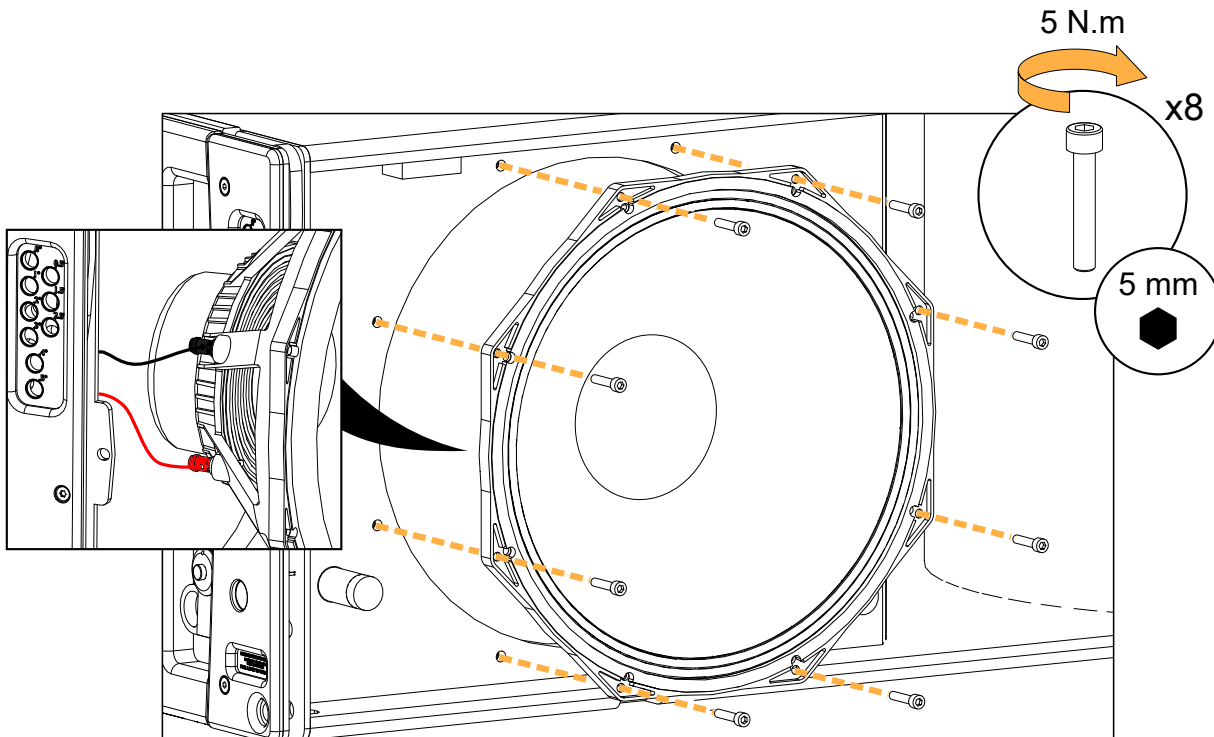

Specifications

K1 specifications

Description	3-way full-range active WST® enclosure, quad-amplified by LA12X
Usable bandwidth (-10 dB)	35 Hz - 20 kHz ([K1])
Maximum SPL¹	149 dB ([K1])
Nominal directivity (-6 dB)	horizontal: 90° symmetric vertical: dependent upon the number of elements and the line source curvature
Transducers	LF: 2 × 15" neodymium MF: 4 × 6.5" neodymium, direct-radiating HF: 3 × 3" diaphragm compression drivers
Acoustical load	LF: bass-reflex MF: bass-reflex HF: DOSC waveguide
Nominal impedance	LF: 2 × 8 Ω MF: 8 Ω HF: 8 Ω
Connectors	IN: 1 × 8-point PA-COM LINK: 1 × 8-point PA-COM
Rigging and handling	4 handles integrated into the cabinet inter-enclosure angles: 0°, 0.5°, 1°, 1.5°, 2°, 2.5°, 3°, 4° or 5°
Weight (net)	106 kg / 234 lb
Cabinet	premium grade Baltic birch plywood high density polyethylene
Front	coated steel grill acoustically neutral 3D fabric
Rigging components	high grade steel with anti-corrosion coating
Finish	grey brown RAL 8019
IP	IP43

¹ Peak level measured at 1 m under free field conditions using pink noise with crest factor 4 (preset specified in brackets).

K1 dimensions

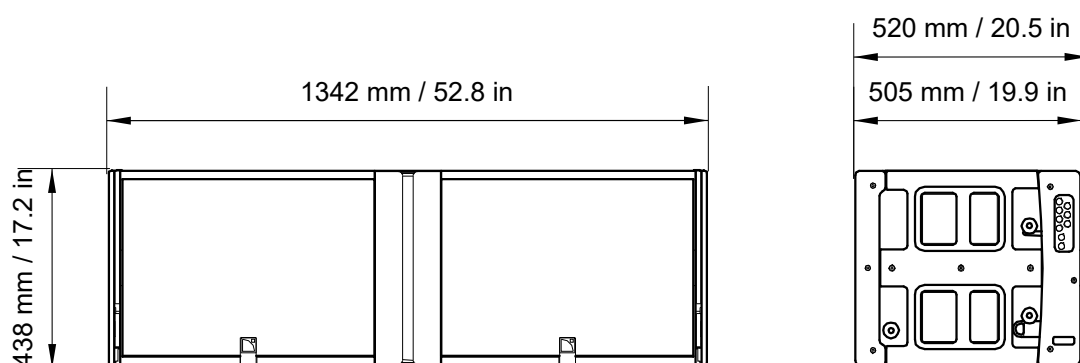

K2 specifications

Description	3-way full-range active WST enclosure, quad-amplified by LA4X / LA12X
Usable bandwidth (-10 dB)	35 Hz - 20 kHz ([K2 70])
Maximum SPL ¹	147 dB ([K2 70])
Nominal directivity (-6 dB)	horizontal: 110°/70° symmetric or 90° asymmetric (35°/55° or 55°/35°) vertical: dependent upon the number of elements and the line source curvature
Transducers	LF: 2 × 12" cone drivers MF: 4 × 6.5" cone drivers HF: 2 × 3" diaphragm compression drivers
Acoustical load	LF: bass-reflex, L-Vents MF: bass-reflex HF: DOSC waveguide
Nominal impedance	LF: 2 × 8 Ω MF: 8 Ω HF: 16 Ω
Connectors	IN: 1 × 8-point PA-COM LINK: 1 × 8-point PA-COM
Rigging and handling	4-point captive rigging system inter-enclosure angles: 0.25°, 1°, 2°, 3°, 4°, 5°, 7.5° or 10°
Weight (net)	56 kg / 123.2 lb
Cabinet	premium grade Baltic birch plywood
Front	coated steel grill acoustically neutral 3D fabric
Rigging components	high grade steel with anti-corrosion coating
Finish	dark grey brown Pantone 426 C
IP	IP55

¹ Peak level measured at 1 m under free field conditions using pink noise with crest factor 4 (preset specified in brackets).

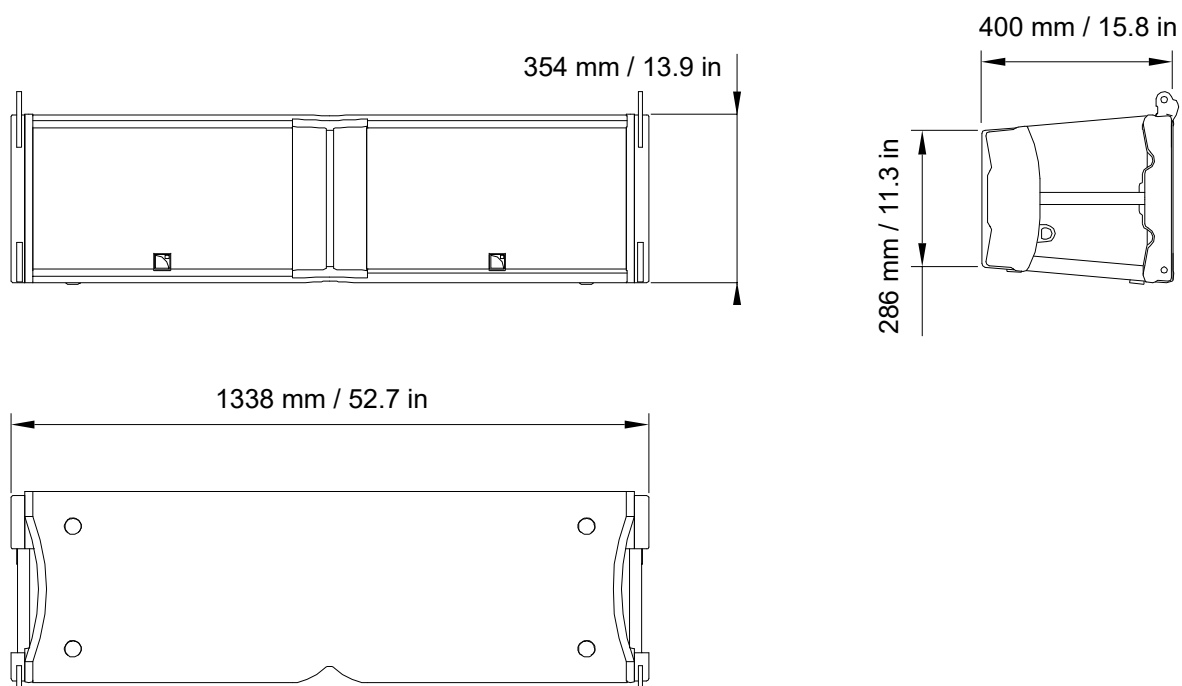
K2 dimensions

K1-SB specifications

Description	K1 system subwoofer 2×15", amplified by LA12X
Low frequency limit (-10 dB)	30 Hz ([K1SB_60])
Maximum SPL¹	145 dB ([K1SB_X])
Transducers	2 × 15" cone drivers
Acoustical load	bass-reflex, L-Vents
Nominal impedance	4 Ω
Connectors	IN: 1 × 4-point speakON
Rigging and handling	captive rigging system 4-point rigging system inter-enclosure angles: 0°, 0.5°, 1°, 1.5°, 2°, 2.5°, 3°, 4° or 5° 4 handles integrated into the cabinet
Weight (net)	83 kg / 183 lb
Cabinet	premium grade Baltic birch plywood
Front	coated steel grill acoustically neutral 3D fabric
Rigging components	high grade steel with anti-corrosion coating
Finish	dark grey brown Pantone 426 C pure white RAL 9010
IP	IP45

¹ Peak level at 1 m under half space conditions using pink noise with crest factor 4 (preset specified in brackets).

K1-SB dimensions

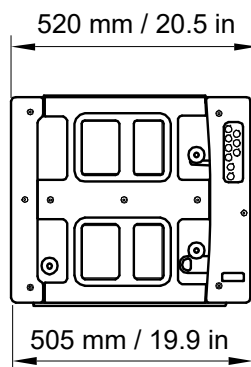
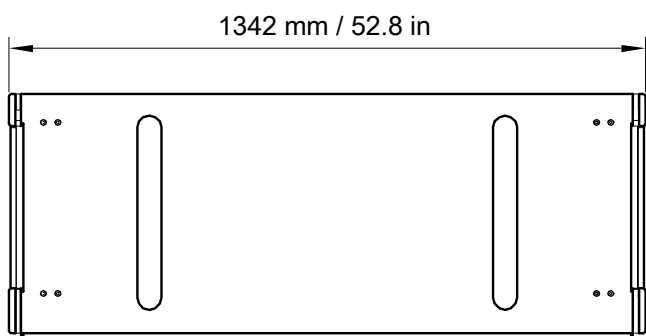
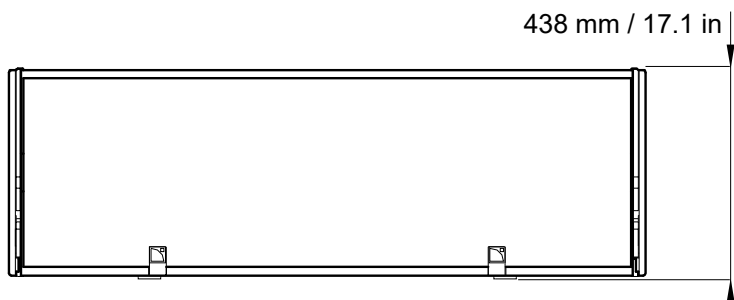
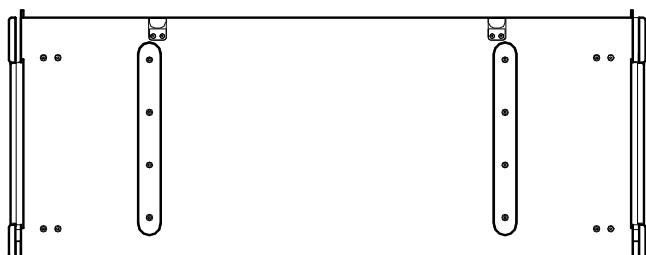

Kara II specifications

Description	2-way active WST® enclosure: 2 × 8" LF + 3" HF diaphragm, amplified by LA4X / LA12X
Usable bandwidth (-10 dB)	55 Hz - 20 kHz ([KARA II 70])
Maximum SPL ¹	142 dB ([KARA II 70])
Nominal directivity (-6 dB)	horizontal: 70° / 110° symmetric or 90° asymmetric (35°/90°) vertical: dependent upon the number of elements and the line source curvature
Transducers	LF: 2 × 8" neodymium cone drivers HF: 1 × 3" neodymium diaphragm compression driver
Acoustical load	LF: bass-reflex HF: DOSC waveguide, L-Fins
Nominal impedance	LF: 8 Ω HF: 8 Ω
Connectors	IN: 1 × 4-point speakON LINK: 1 × 4-point speakON
Rigging and handling	4-point captive rigging system 2 side handles 2 rear handles inter-enclosure angles: 0°, 1°, 2°, 3°, 4°, 5°, 7.5° or 10°
Weight (net)	26 kg / 57 lb
Cabinet	premium grade Baltic birch plywood
Front	coated steel grill acoustically neutral 3D fabric
Rigging components	high grade steel with anti-corrosion coating
Finish	dark grey brown Pantone 426 C
IP	IP55

¹ Peak level measured at 1 m under free field conditions using pink noise with crest factor 4 (preset specified in brackets).

Kara II dimensions

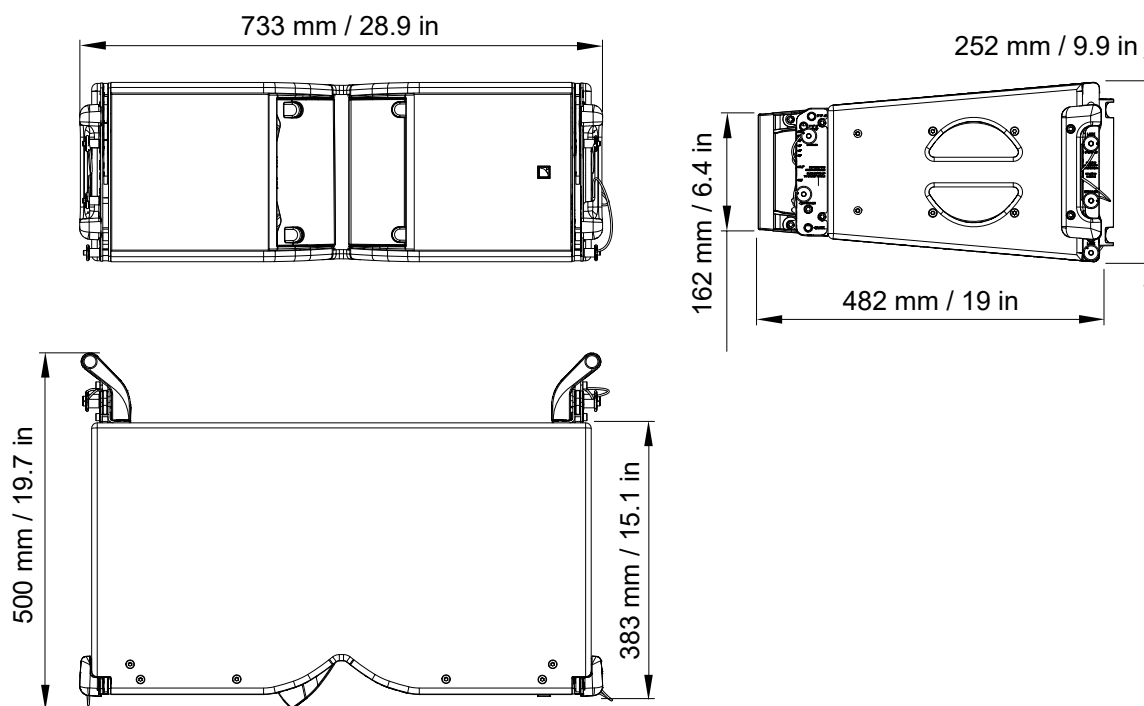

KS28 specifications

Description	Flyable subwoofer 2 × 18", amplified by LA2Xi / LA12X
Low frequency limit (-10 dB)	25 Hz ([KS28_100])
Maximum SPL¹	143 dB ([KS28_100]) with LA2Xi (bridge mode) / LA12X 136 dB ([KS28_100]) with LA2Xi
Directivity	standard or cardioid
Transducers	2 × 18" neodymium cone drivers
Acoustical load	bass-reflex, L-Vents
Nominal impedance	4 Ω
Connectors	IN: 1 × 4-point speakON
Rigging and handling	flush-fitting 2-point rigging system 6 ergonomic handles 2 ground runners 8 side runners
Weight (net)	79 kg / 174 lb
Cabinet	premium grade Baltic beech and birch plywood
Front	coated steel grill acoustically neutral 3D fabric
Rigging components	high grade steel
Finish	dark grey brown Pantone 426 C
IP	IP55

¹ Peak level at 1 m under half space conditions using pink noise with crest factor 4 (preset specified in brackets).

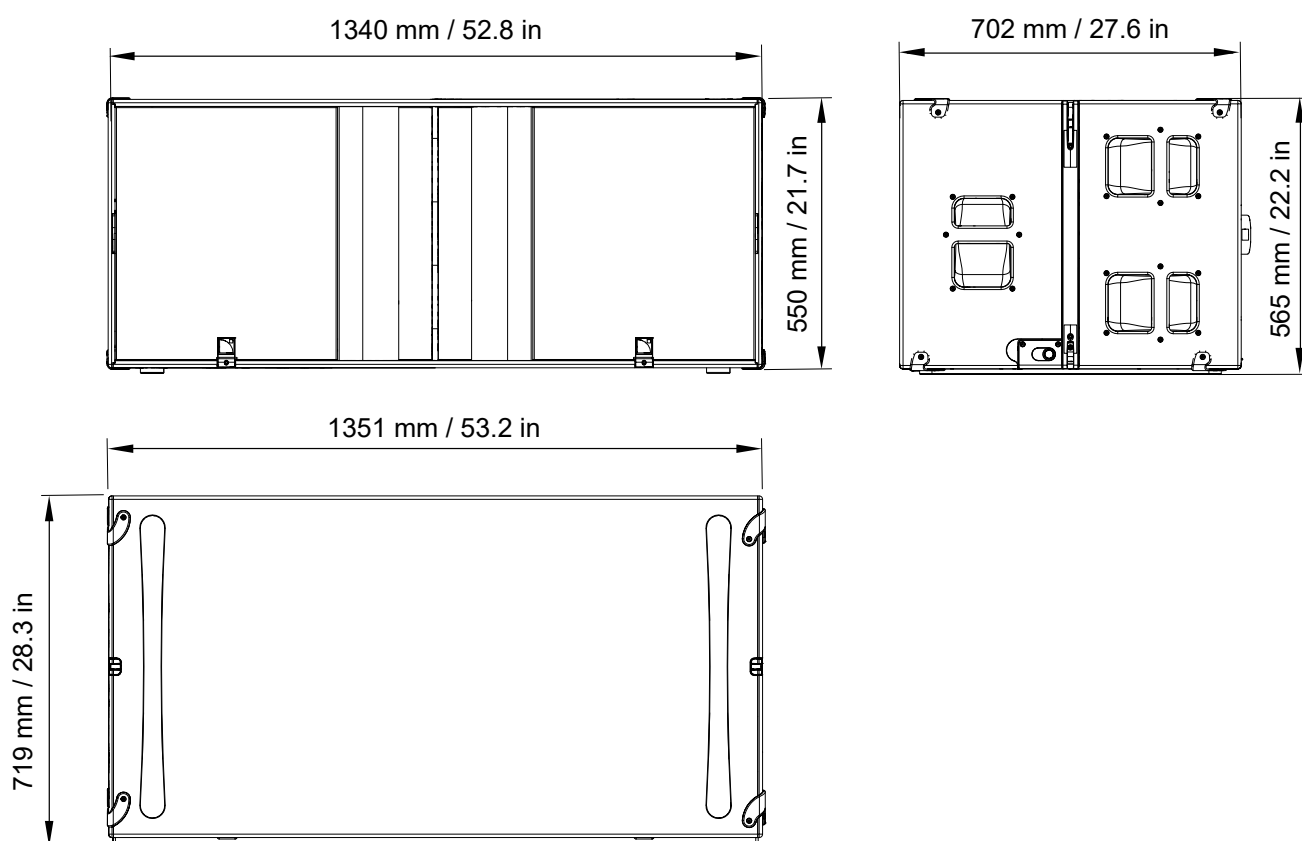
KS28 dimensions

K1-BPCHAIN specifications

Description	Adjustable sling for K1-BUMP or K2-BUMP
Weight (net)	6.3 kg / 13.9 lb
Material	high grade steel with anti-corrosion coating

K1-BPCHAIN dimensions

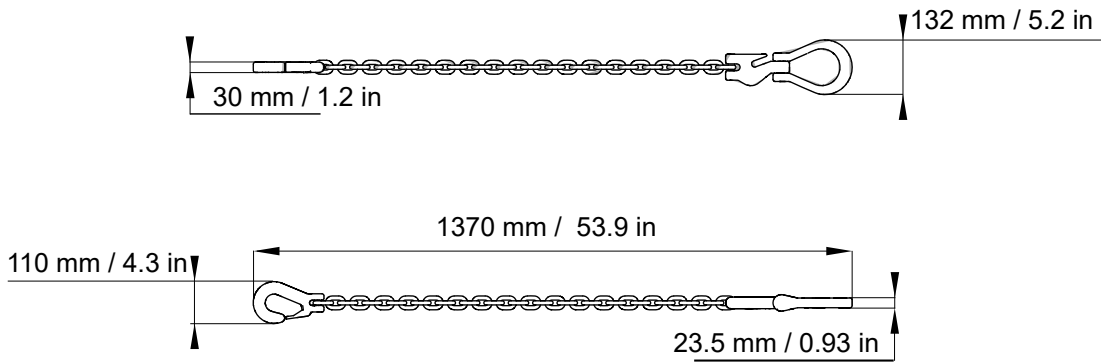

K1-BUMP specifications

Description	Structure for flying and stacking K1 and K1-SB arrays
Weight (net)	98 kg / 216 lb
Material	high grade steel with anti-corrosion coating

K1-BUMP dimensions

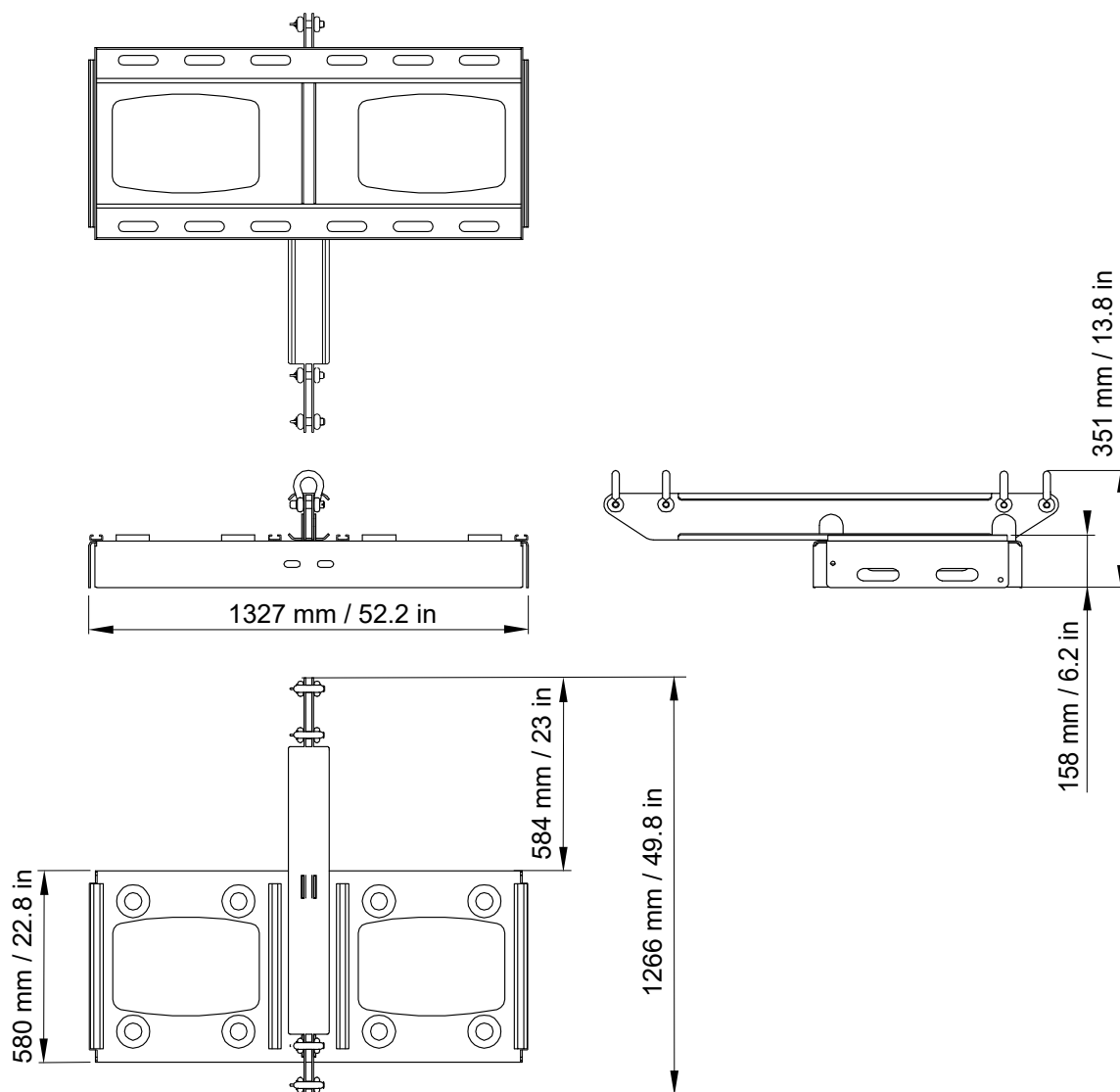

K1-CHARIOT specifications

Description	Chariot for 4 × K1 or 4 × K1-SB
Weight (net)	47 kg / 103 lb
Material	high grade steel with anti-corrosion coating

K1-CHARIOT dimensions

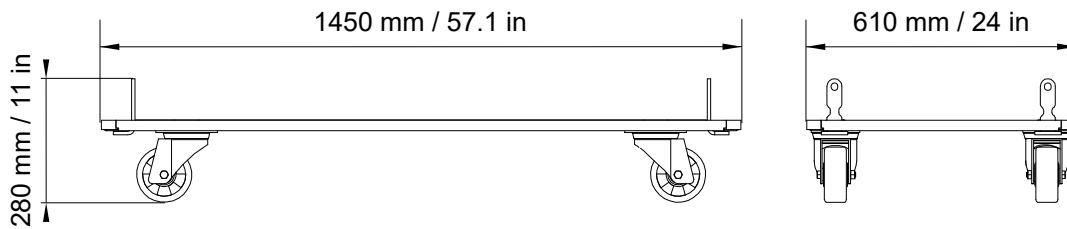

K1-DELTA specifications

Description	Rigging accessory for rear attachment of 2 motors to K1-BUMP
Weight (net)	9.5 kg / 21 lb
Material	high grade steel with anti-corrosion coating

K1-DELTA dimensions

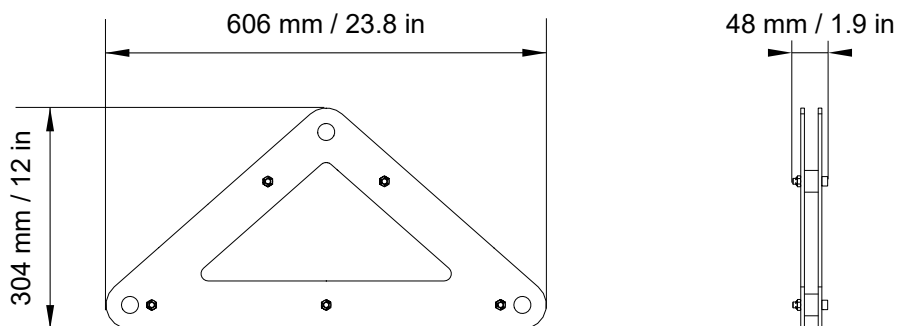

K1-LASERMOUNT specifications

Description	K1 laser support plate (compatible TEQSAS / SSE Prosight / Align Array / KSG)
Weight (net)	0.8 kg / 1.8 lb
Material	high grade steel with anti-corrosion coating

K1-LASERMOUNT dimensions

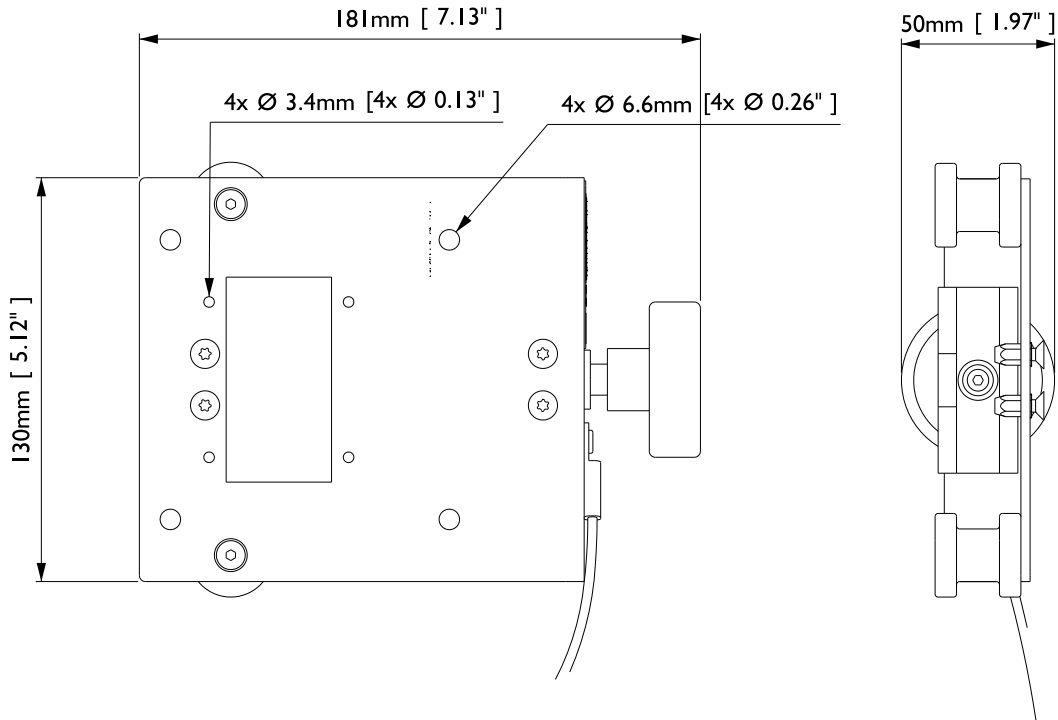

K1-PLA specifications

Description Removable front dolly for K1 or K1-SB enclosure

Weight (net) 7.5 kg / 16.5 lb

Material high grade steel with anti-corrosion coating

K1-PLA dimensions

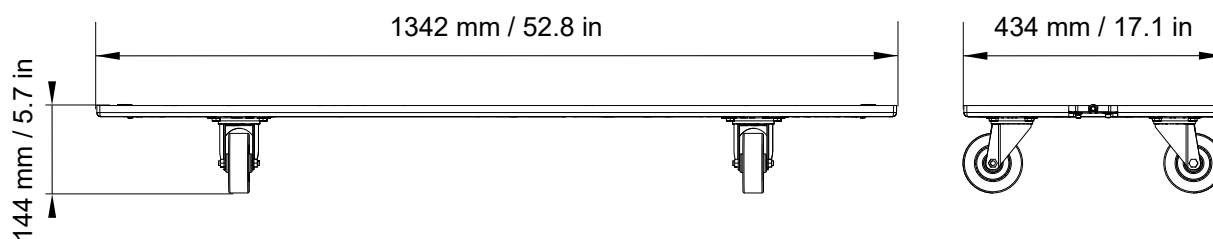

KARA-DOWNK1 specifications

Description	Flying bumper for rigging KARA (II) under K1 or K1-SB
Weight (net)	21 kg / 46 lb
Material	high grade steel with anti-corrosion coating

KARA-DOWNK1 dimensions

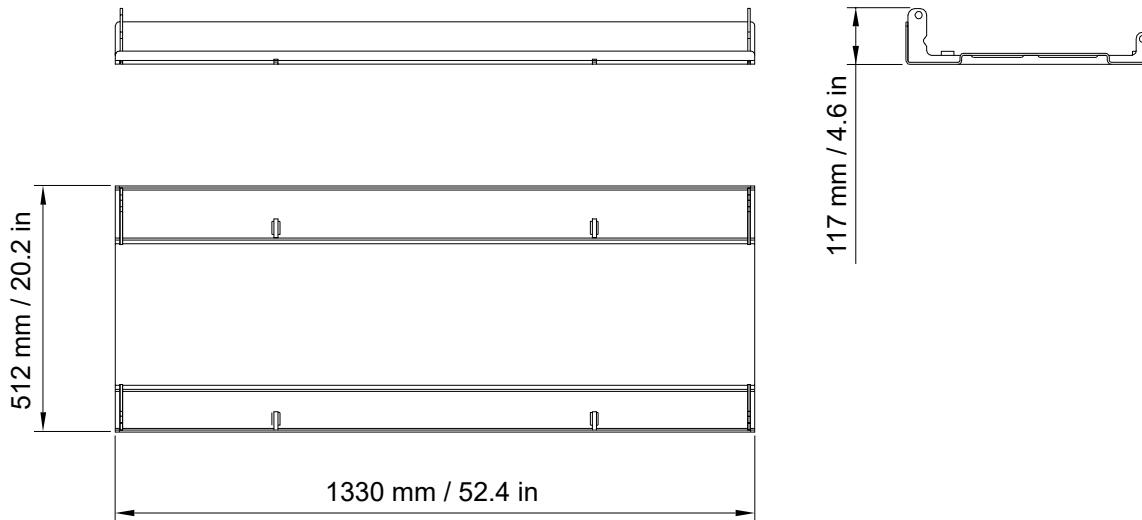

K2-LINK specifications

Description	Rigging accessory for rear attachment of K2 below K1
Weight (net)	1.8 kg / 4 lb
Material	high grade steel with anti-corrosion coating

K2-LINK dimensions

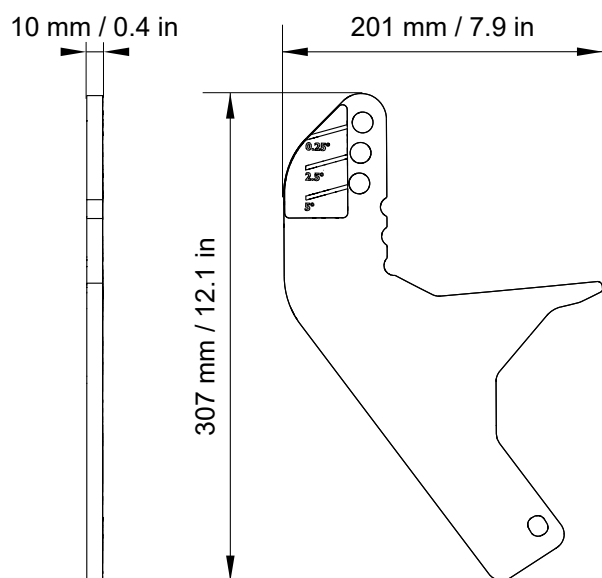

K-BUMPFLIGHT specifications

Description	Modular flight case for 2 K1-BUMP or 2 K2-BUMP 12 pieces of adhesive foam
Weight (net)	105 kg / 231.5 lb

K-BUMPFLIGHT dimensions

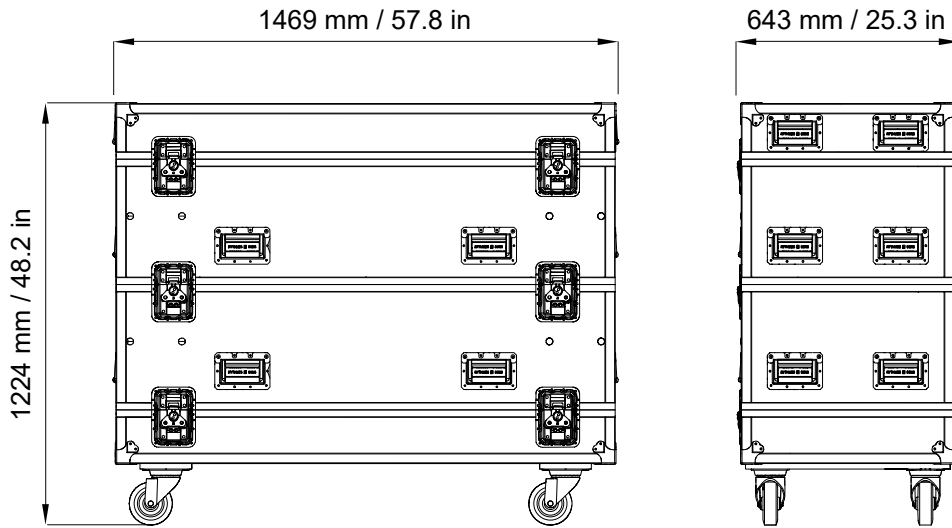

KS28-OUTRIG specifications

Description	Stability bars for KS28
Weight (net)	9.4 kg / 20 lb
Material	high grade steel with anti-corrosion coating

KS28-OUTRIG dimensions

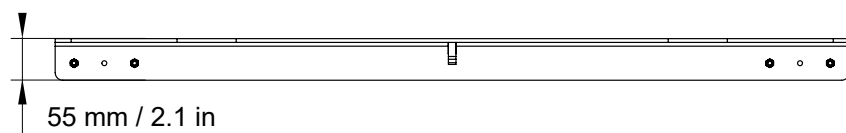
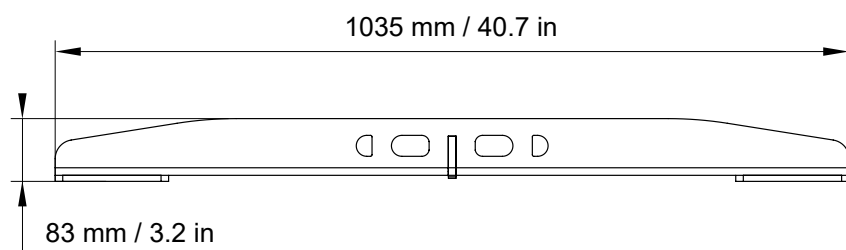

Recommendation for speaker cables



Cable quality and resistance

Only use high-quality fully insulated loudspeaker cables made of stranded copper wire.

Use cables with a gauge offering low resistance per unit length and keep the cables as short as possible.

It is good practice to keep loudspeaker cables short to ensure optimal system performance. L-Acoustics strongly recommends using cables of similar type, length, and gauge to address symmetrical deployment of loudspeakers, such as stereo systems, L-ISA frontal systems, or outfill systems.



For more information about cable effect on loudspeaker frequency response, refer to the publication **Demystifying the effects of loudspeaker cables** on the L-Acoustics website, in **Education > Scientific resources > Scientific publications**.

Refer to the following table for recommended cable length for uncompromised performance.

cable gauge			recommended maximum length					
			8 Ω load		4 Ω load		2.7 Ω load	
mm ²	SWG	AWG	m	ft	m	ft	m	ft
1.5	18	16	18	60	9	30	–	–
2.5	15	14	30	100	15	50	10	33
4	13	11	50	160	25	80	17	53
6	11	9	74	240	37	120	25	80

Use the more detailed L-Acoustics calculation tool to evaluate cable length and gauge based on the type and number of loudspeakers connected. The calculation tool is available on our website:

<https://www.l-acoustics.com/installation-tools/>

Installing a laser inclinometer

K1-LASERMOUNT

K1-LASERMOUNT can be used to secure a laser inclinometer vertically or horizontally, using the L-Acoustics Tech Toolcase II accessories.

Five sensor models can be used:

- TEQSAS® LAP-TEQ PLUS (L-Acoustics Tech Toolcase II accessory)
- TEQSAS® LAP-TEQ (legacy model)
- KSG® RECLINE Compact
- UVM sensor
- SSE® ProSight



LAP-TEQ / LAP-TEQ PLUS sensor and display compatibility

The legacy LAP-TEQ sensors are compatible with the new TEQSAS® LAP-TEQ PLUS displays. Conversely, the new sensors are not compatible with the legacy displays.



TEQSAS® LAP-TEQ calibration

Make sure the sensor is calibrated for vertical use.

With screws

Mount the inclinometer on K1-LASERMOUNT:

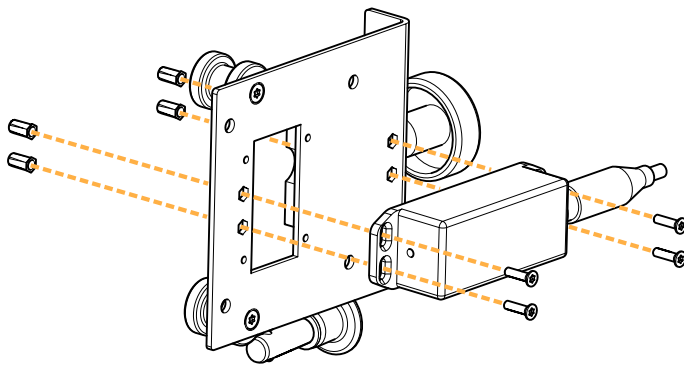

Vertical mount

K1-BUMP

K1-BUMP features a support plate to accommodate a laser inclinometer.

Four sensor models can be used:

- TEQSAS® LAP-TEQ PLUS (L-Acoustics Tech Toolcase II accessory)
- TEQSAS® LAP-TEQ (legacy model)
- KSG® RECLINE Compact
- SSE® ProSight



LAP-TEQ / LAP-TEQ PLUS sensor and display compatibility

The legacy LAP-TEQ sensors are compatible with the new TEQSAS® LAP-TEQ PLUS displays. Conversely, the new sensors are not compatible with the legacy displays.



TEQSAS® LAP-TEQ calibration

Make sure the sensor is calibrated for vertical use

With TEQSAS® LAP-TEQ PLUS / LAP-TEQ / KSG® RECLINE Compact

About this task



TEQSAS® LAP-TEQ calibration

Make sure the sensor is calibrated for vertical use.

Procedure

1. Remove the four M4 Torx screws (T20) from the plate.

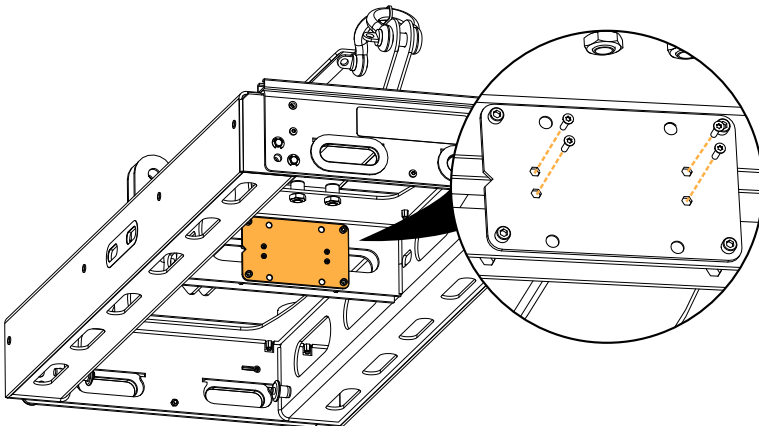

2. Put thread-locker in the four threaded inserts.
3. Position the sensor so it points toward the front of the K1-BUMP.
4. Secure the sensor with the four screws.

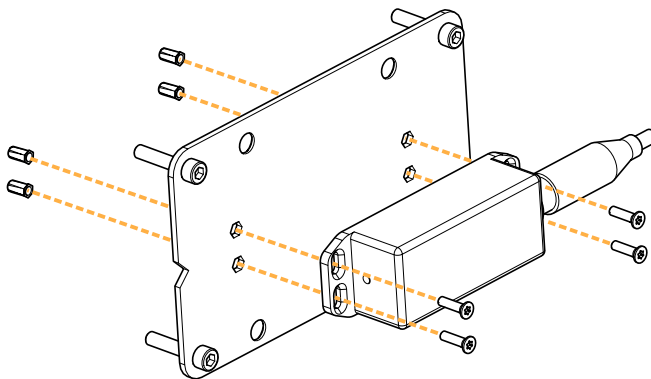

5. Connect the XLR cable to the sensor.
6. Refer to the **manufacturer instructions** to calibrate the inclinometer.

With SSE® Prosight

SSE Prosight2 is a SSE product. Refer to the [SSE Fitting guides](#) for more information on how to mount SSE Prosight on a K Series bumper.



L-Acoustics

13 rue Levacher Cintrat - 91460 Marcoussis - France
+33 1 69 63 69 63 - info@l-acoustics.com
www.l-acoustics.com

 **L.ACOUSTICS**
GROUP